

CBCS SCHEME

USN

--	--	--	--	--	--	--	--	--	--

15EE553

Fifth Semester B.E. Degree Examination, June/July 2019

Electrical Estimation and Costing

Time: 3 hrs.

Max. Marks: 80

Note: Answer any FIVE full questions, choosing ONE full question from each module.

Module-1

- a. Define Estimating and State its purpose. State the important facts, which an estimator should know for preparing an Internal wiring estimate. (08 Marks)
b. Write note on the Comparative Statement. (08 Marks)

OR

- a. Explain IE77 and IE79. (08 Marks)
b. State the rules to be observed while Inviting tenders. (08 Marks)

Module-2

- a. What is the function of a fuse? Why it is connected in the phase wire? (04 Marks)
b. Draw the electrical circuit and estimate the quantity of materials and their cost required for PVC casing – capping used in a house, the plan of which is shown in fig.Q3(b). Assume the height of ceiling as 3.6 metres and one plug point is to be provided in each room. (12 Marks)

Fig.Q3(b)

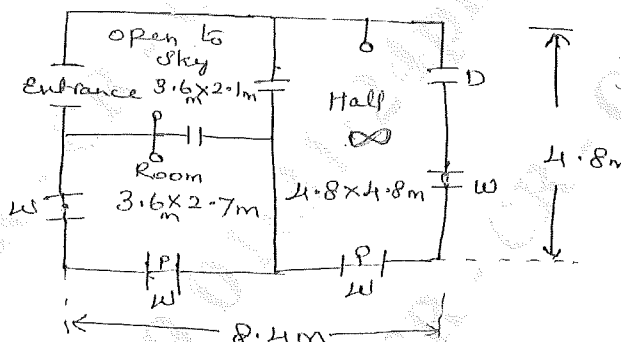

OR

- a. Write the general rules to be consider for wiring system. (04 Marks)
b. Draw the electric circuit and estimate the Quantity of material and total cost for PVC wiring system used in a hall of 15m x 6m x 4.5m height , the hall is to be fitted with fan points and light points make your own assumptions for the number of fan and light points and other missing datas. (12 Marks)

Module-3

- a. What are the important considerations regarding motor installation wiring? (06 Marks)
b. Prepare a list of material and estimate the cost for providing service connection to a single storey building at 240V, 1 ϕ , 50Hz having a light and fan load of 5kW. The supply is to be given from an overhead line 20m away from the building. (10 Marks)

OR

Important Note : 1. On completing your answers, compulsorily draw diagonal cross lines on the remaining blank pages.
2. Any revealing of identification, appeal to evaluator and /or equations written eg. 42+8 = 50, will be treated as malpractice.

- 6 a. What do you understand by service line? Write down the various methods of Installing service lines. (06 Marks)
- b. A 10Hp , 415V, 3 ϕ , 50Hz Induction motor is to be installed in a workshop, the plan of which is shown below in fig. Q6(b). Show the layout of the wiring and estimate the quantity of material required and give in approximate cost the wiring is to be surface conduct. (10 Marks)

Fig.Q6(b)

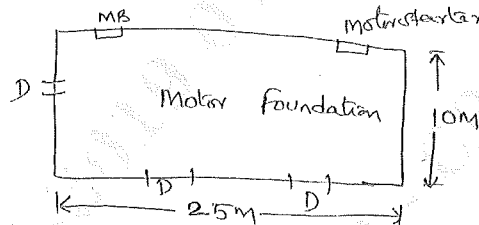
**Module-4**

- 7 a. Give the points to be considered at the time of erection of overhead lines. (06 Marks)
- b. An overhead 11KV, 50Hz line has to be erected using 27kg, 10 meter long steel poles and copper wire of size no. 3/2.642mm, with average span of 150 meters. Make a list of material required and estimate the cost per kilometer. (10 Marks)

OR

- 8 a. Explain the procedure of earthing of Transmission lines. (08 Marks)
- b. Estimate the Quantity of material required and cost of 1km of overhead 11KV, 50Hz line using steel poles of 11 meter height and ACSR conductor of $\frac{6}{1} \times 2.59$ mm with an average span of 120m. (08 Marks)

Module-5

- 9 a. Describe briefly the equipment that must be available in a substation. (08 Marks)
- b. Prepare a list of material required and work out the cost of installation of a 400 KVA indoor type 11/0.433 KV X^r (transformer). (08 Marks)

CMRIT LIBRARY
BANGALORE - 560 037

OR

- 10 A 37 KW connection is to be given to an agriculture field at 415V, 3 ϕ , 50Hz, the connection is to be given from a 3 ϕ , 11KV, overhead distribution line which is available at a distance of 40m. The motor has a full load efficiency of 85% and power factor 0.8. Make a neat sketch showing how will you arrange the supply and estimate quantity of material required with cost. (16 Marks)

* * * * *