

USN

--	--	--	--	--	--	--	--	--	--

CMRIT LIBRARY  
BANGALORE - 560 037

10ES32

**Third Semester B.E. Degree Examination, June/July 2018**  
**Analog Electronics Circuits**

Time: 3 hrs.

Max. Marks:100

**Note: Answer FIVE full questions, selecting at least TWO questions from each part.**

**PART - A**

- 1 a. Assuming an ideal diode, sketch  $v_i$ ,  $v_d$  and  $i_d$  for half-wave rectifier of Fig.1(a). The input is a sinusoid with frequency 50 Hz. (08 Marks)

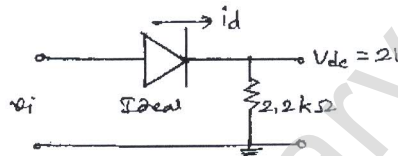

Fig.Q1(a)

- b. Determine  $v_o$  for the network shown in Fig.Q1(b). (06 Marks)

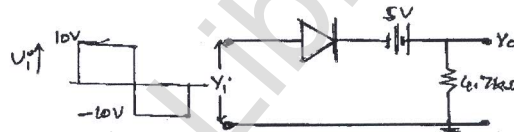

Fig.Q1(b)

- c. Sketch  $v_o$  for the network shown in Fig.Q1(c). (06 Marks)

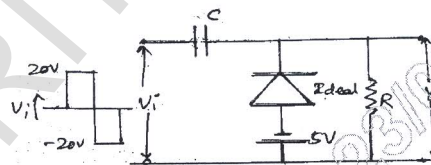

Fig.Q1(c)

- 2 a. Using exact analysis, obtain the Q-point values for the voltage-divider bias circuit. (08 Marks)
- b. Obtain the expression for  $S(I_{CO})$  for an emitter-bias circuit and determine its value for the circuit with  $R_B = 470 \text{ k}\Omega$ ,  $R_E = 2.2 \text{ k}\Omega$ ,  $R_C = 3.3 \text{ k}\Omega$ ,  $V_{CC} = 12 \text{ V}$  and  $\beta = 100$ . (06 Marks)
- c. For the circuit shown in Fig.Q2(c), determine the values for  $R_1$  and  $R_C$ . (06 Marks)

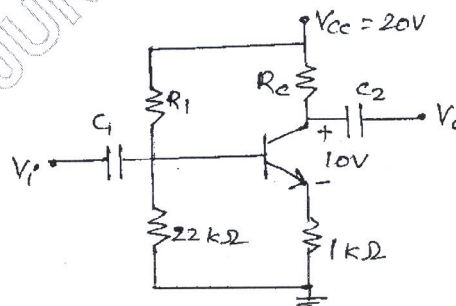

Fig.Q2(c)

Important Note : 1. On completing your answers, compulsorily draw diagonal cross lines on the remaining blank pages.  
2. Any revealing of identification, appeal to evaluator and /or equations written eg. 42+8 = 50, will be treated as malpractice.

- 3 a. Derive the equations for  $Z_i$ ,  $Z_o$  and  $A_v$  for fully bypassed common emitter RC-coupled amplifier. (08 Marks)
- b. Compare  $Z_i$ ,  $Z_o$  and  $A_v$  of a RC coupled amplifier with emitter follower and explain why emitter follower is called as impedance matching network. (06 Marks)
- c. For the circuit shown in Fig.Q3(c), find  $Z_i$ ,  $Z_o$  and  $A_v$ . (06 Marks)

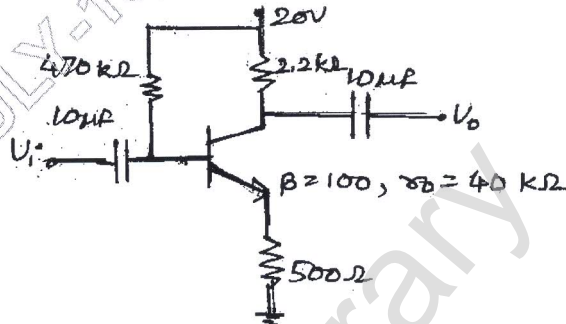

Fig.Q3(c)

- 4 a. Draw the frequency response of RC coupled amplifier and explain high-pass action at low frequencies and low-pass action at high frequencies with relevant equations and Bode plots. (08 Marks)
- b. Draw the high frequency equivalent circuit for RC coupled amplifier and obtain expressions for  $f_{Hi}$  and  $f_{Ho}$ . (06 Marks)
- c. Determine  $f_{Cs}$  and  $f_{Cc}$  for circuit with,  
 $C_S = 10\mu F$ ,  $C_E = 20\mu F$ ,  $C_C = 1\mu F$ ,  $R_S = 1k\Omega$ ,  $R_1 = 40k\Omega$ ,  $R_2 = 10k\Omega$ ,  $R_E = 2k\Omega$ ,  $R_C = 4k\Omega$ ,  $R_L = 2.2k\Omega$ ,  $\beta = 100$ ,  $r_0 = \infty$ ,  $V_{CC} = 20V$ . (06 Marks)

PART - B

- 5 a. Explain the advantages of employing negative feedback in an amplifier. (06 Marks)
- b. Derive an equation for  $Z_i$  and  $A_v$  for a Darlington emitter follower. (08 Marks)
- c. For cascaded stages shown in Fig.Q5(c), determine :  
 i) Loaded gain for each stage  
 ii) Total gain for the system  $A_v$  and  $A_{vs}$ . (06 Marks)

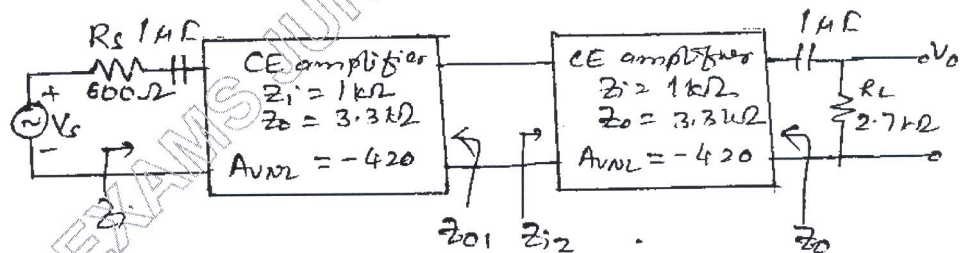

Fig.Q5(c)

- 6 a. Derive the expression for maximum percentage efficiency for a seriesfed class-A power amplifier. (08 Marks)
  - b. Calculate the second harmonic distortion for an output waveform with  $V_{CEQ} = 10V$ ,  $V_{CE_{min}} = 1V$ ,  $V_{CE_{max}} = 18V$ . (06 Marks)
  - c. Draw the circuit of a class-B push-pull amplifier and explain the working. Explain why cross-over distortion occurs in class-B and how it is overcome. (06 Marks)
- 7 a. With a neat circuit diagram, explain the principle of operation of RC phase-shift oscillator with necessary equations. (08 Marks)
  - b. Explain the working of transistor crystal oscillator in series resonant mode. (06 Marks)
  - c. Design a Weinbridge oscillator for a frequency of 4KHz. (06 Marks)
- 8 a. Derive equations for  $Z_i$ ,  $Z_0$  and  $A_v$  for JFET fixed bias configuration, with source resistor bypassed. (08 Marks)
  - b. For JFET amplifier shown in Fig.Q8(b), find  $Z_i$ ,  $Z_0$  and  $A_v$ . (08 Marks)

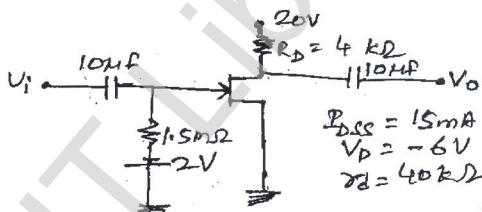

Fig.Q8(b)

- c. Explain the graphical determination of  $g_m$ . (04 Marks)

\*\*\*\*\*