

USN

--	--	--	--	--	--	--	--	--	--

10ME52

Fifth Semester B.E. Degree Examination, Dec.2017/Jan.2018

### Design of Machine Elements – I

Time: 3 hrs.

Max. Marks:100

- Note:** 1. Answer any FIVE full questions, selecting at least TWO questions from each part.  
 2. Use of design data handbook is permitted.  
 3. Missing data may suitably be assumed.

#### PART – A

- 1 a. Briefly explain important mechanical properties of materials. (06 Marks)
- b. A round rod of 60 mm diameter is subjected to bending moment of 900 Nm and a twisting moment of 1200 Nm. Determine the maximum normal and shear stresses induced in the rod. (08 Marks)
- c. A 1 mm thick steel hacksaw blade is bent into circular arc of radius 500 mm. Determine the bending moment applied and the stress induced. The width of blade is 15 mm. Modulus of elasticity is 200 GPa. (06 Marks)
- 2 a. A steel shaft having yield strength of 328.6 MPa is subjected to the following stresses.  $\sigma_x = 90$  MPa,  $\sigma_y = 60$  MPa and  $\tau_{xy} = 30$  MPa. Find the factor of safety according to the following theories of failure: (i) Rankine's theory, (ii) Guest's theory. (06 Marks)
- b. A stepped shaft with diameters ratio as 1.2 and a fillet radius of 10% of smaller diameter is required to transmit 30 kW at 600 rpm. Find the diameter of the shaft taking stress concentration into account. The allowable shear stress is 60 MPa. (06 Marks)
- c. Describe expression for maximum stress induced in axial impact. (08 Marks)
- 3 a. Derive Soderberg's relation for ductile materials. (06 Marks)
- b. A cantilever beam of rectangular cross section having a span of 1200 mm and depth of 200 mm is subjected to a transverse load at its end that fluctuates between 60 kN upward to 120 kN downward. It is made of steel having endurance stress of 270 MPa, ultimate stress of 550 MPa and yield stress of 400 MPa. Find the width of the section taking factor of safety as 2.5. The size and surface factors are 0.9 and 0.95 respectively. (14 Marks)
- 4 a. A bolt is subjected to a tensile load of 12 kN and a tightening load of 3 kN. It is made of steel having allowable tensile stress of 120 MPa. A soft copper gasket is used. Find the size of the bolt. (06 Marks)
- b. A bracket is bolted as shown in Fig.Q4(b). All the bolts are identical and have allowable stress of 60 MPa. Determine the size of the bolt.

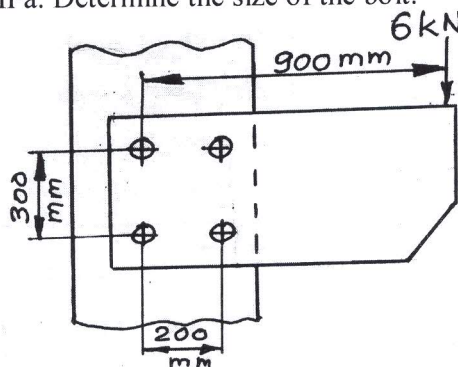

Fig.Q4(b)

(14 Marks)

**PART – B**

- 5 a. Write the advantages of hollow shafts over solid shafts. (04 Marks)
- b. A shaft is supported on two bearings at a distance of 900 mm. A pulley 600 mm diameter weighing 1200 N is mounted on it at 300 mm to the left of right bearing and receives a power of 9 kW at 450 rpm. The power is given out through a pinion 270 mm diameter mounted at 300 mm to the right of left bearing. The belt drive is horizontal and the pinion drives with a downward tangential force. The belt tensions ratio is 3:1. The combined shock and fatigue factors in bending and torsion may be taken as 2 and 1.5 respectively. Find suitable diameter of the shaft taking allowable tensile and shear stresses as 75 MPa and 54 MPa respectively. (16 Marks)
- 6 a. Design a knuckle joint to sustain a tensile load of 90 kN. The allowable stresses for rods and pin are 90 MPa in tension, 60 MPa in shear and 150 MPa in crushing. (10 Marks)
- b. Design a CI flange coupling to transmit 15 KW at 1200 rpm. The allowable shear stress for CI flange is 3 MPa and for shaft, keys and bolts is 75 MPa. The allowable bearing stress for key is 150 MPa. (10 Marks)
- 7 a. Design a double riveted double strap butt joint for the longitudinal seam of a boiler of diameter 1.2 m and a steam pressure of 2 MPa. The following stresses may be used:  
 Allowable tensile stress for plates = 90 MPa  
 Allowable shear stress for rivets = 60 MPa  
 Allowable crushing stress for rivets = 135 MPa.  
 Assume a joint efficiency of 75%. (10 Marks)
- b. Determine the size of weld for a bracket welded as shown in Fig.Q7(b). The allowable stress in the weld is 75 MPa.

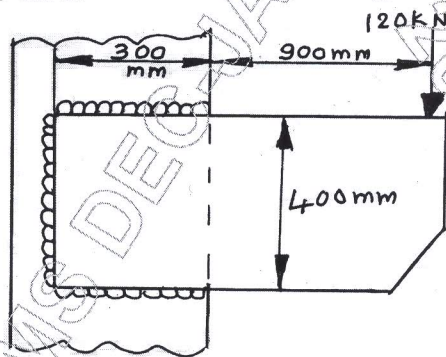

Fig.Q7(b)

(10 Marks)

- 8 a. Derive expression for maximum efficiency of a square threaded screw. (05 Marks)
- b. The lead screw of a lathe machine has a single start ISO trapezoidal threads of 30 mm outside diameter and 6 mm pitch. It drives a tool carriage against a cutting force of 6 kN at a speed of 720 mm/min. The end of the screw is carried on a thrust washer of outside and inside diameters of 50 mm and 30 mm. the coefficient of thread friction is 0.12 and that for collar is 0.15. Find:
- The torque required to drive the carriage.
  - Power of motor.
  - The efficiency.
  - Compressive stress induced in the screw.
  - Length of bronze nut required taking allowable bearing pressure in the threads as 1.5 MPa. (15 Marks)

\*\*\*\*\*