

USN

--	--	--	--	--	--	--	--	--	--

10ME62

Sixth Semester B.E. Degree Examination, Dec.2018/Jan.2019

**Design of Machine Elements – II**

Time: 3 hrs.

Max. Marks:100



- Note:** 1. Answer any FIVE full questions, selecting at least TWO questions from each part.  
 2. Use of design data hand book is permitted.  
 3. Any additional data if required can be assumed.

**PART – A**

- 1
  - a. The cross section of a steel crane hook is a trapezium with an inner side of 120 mm and outside 60 mm. The depth of the section is 90 mm. The load line is 15 mm away from the centre of curvature. Determine the safe load that the hook can carry, if the allowable stress of 90 MPa. (10 Marks)
  - b. A thick cylinder 120 mm inner diameter and 200 mm outer diameter carries fluid under a pressure of 9 MPa. Find the tangential and radial stresses across the wall and sketch the stress distribution. (10 Marks)
- 2
  - a. A 12 mm thick flat belt is required to transmit 12 KW of power from a pulley 300 mm diameter running at 900 rpm to another pulley to run at 500 rpm. The allowable stress for belt material is 2.1 MPa. Coefficient of friction is 0.25 and centre distance between pulley is 1.8 m. find the width and length of belt. Also find the initial tension in the belt. (10 Marks)
  - b. Select a V-belt drive to transmit 18 KW at 1500 rpm to another pulley to run at 750 rpm. (10 Marks)
- 3
  - a. What is equalized stresses or Nipping in spring leaves? Explain. (06 Marks)
  - b. Design a helical compression spring to support an axial load of 3000 N. the deflection under load is limited to 60 mm. The spring index is 6. The allowable shear stress of spring material is 345 N/mm<sup>2</sup>. The modulus of rigidity is 79340 N/mm<sup>2</sup>. (14 Marks)
- 4
 

It is required to transmit 25 KW of power from a shaft running at 1000 rpm to a parallel shaft with a speed reduction ratio of 2.5:1. The centre distance of the shaft is to be 300 mm. the material used for pinion is steel ( $\sigma_d = 200$  N/mm<sup>2</sup>, BHN = 250) and for gear is cast iron ( $\sigma_d = 180$  N/mm<sup>2</sup>, BHN = 200). Considering class II gear with tooth profile 20° full depth involute. Design the spur gear and check for dynamic and wear load. (20 Marks)

**PART – B**

- 5
 

A pair of 20° full depth involute teeth bevel gears connect two shafts at right angles having velocity ratio 3:1. The gear is made of cast steel 0.20% untreated and the pinion material is of steel C30 heat treated. The pinion has 20 number of teeth and transmits 40 KW at 750 rpm. Determine the module, face width, pitch diameter. Suggest suitable surface hardness for the gear pair. Assume width of gear face as 1/3 rd of the length of pitch cone  $\left[ b = \frac{L}{3} \right]$ . (20 Marks)

- 6 a. A cone clutch has a semi cone angle of  $15^\circ$  and is used to transmit 10 KW at 1500 rpm. The width of the face is one-fourth of the mean diameter of friction lining. The normal intensity of pressure between contact surface is 0.12 MPa and coefficient of friction is 0.2, assuming uniform wear, design the clutch dimensions. Take C40 steel and FOS = 2.5. (10 Marks)
- b. A 360 mm radius brake drum contacts a single shoe as shown in Fig.Q6(b) and sustains a power of 23.5 KW at 1000 rpm. Determine:
- The normal force on the shoe
  - The tangential force
  - The operating force for clockwise rotation
  - The operating force for counter-clockwise rotation
  - The value of distance 'c' for the brake to be self locking
  - The rate of heat generated.

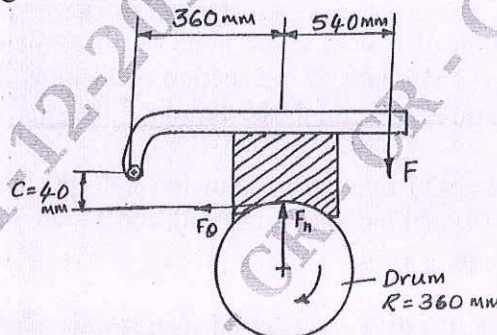

Fig.Q6(b)

(10 Marks)

- 7 a. Derive Petroff's equation for coefficient of friction in journal bearings. (08 Marks)
- b. A 75 mm long full journal bearing of diameter 75 mm supports a radial load of 12 kN at the shaft speed of 1800 rev/min. Assume ratio of diameter to the diametral clearance as 1000. The viscosity of oil is 0.01 Pas at the operating temperature. Determine the following:
- Summerfield number
  - The coefficient of friction based on McKee's equation
  - Amount of heat generated
  - Power loss due to friction.

(12 Marks)

- 8 Design a suitable cast iron piston for a single acting four stroke diesel engine from the following data:

Maximum gas pressure = 3.5 MPa

Fuel consumption = 0.2 kg/brake power in KW/hour

Indicated mean effective pressure = 0.85 MPa

Speed = 300 rpm

Maximum permissible tension for cast iron for the design of head thickness is 30 MPa and for piston pin material is 120 MPa. Bearing pressure for piston pin should not exceed 20 MPa. Cylinder bore diameter is 300 mm and length of stroke is 450 mm. Assume any further data required of the design.

(20 Marks)

\*\*\*\*\*