

# CBCS SCHEME

USN

--	--	--	--	--	--	--	--	--	--	--	--	--	--	--	--	--	--	--	--

15ME62

Sixth Semester B.E. Degree Examination, Dec.2018/Jan.2019

## Computer Integrated Manufacturing

Time: 3 hrs.

Max. Marks: 80

Note: Answer any FIVE full questions, choosing one full question from each module.

### Module-1

- 1 a. Define Automation. Explain the different types of automation in brief with suitable examples. (10 Marks)
- b. Explain the following mathematical models :
  - (i) Manufacturing Lead Time
  - (ii) Production Rate
  - (iii) Availability (06 Marks)

OR

- 2 a. Enumerate the objectives of Automated flow lines. (08 Marks)
- b. With a neat sketch explain Rotary configuration. (08 Marks)

### Module-2

- 3 a. Explain in brief the major functions of Graphics package in mechanized environment. (07 Marks)
- b. A square with an edge length of 10 units is located on the origin with one of the edge at an angle of  $30^\circ$  with positive x-axis. Calculate the new position of the square if it is rotated about z-axis by an angle  $30^\circ$  in clockwise direction. (09 Marks)

OR

- 4 a. With a neat sketch explain Retrieval CAPP system. (08 Marks)
- b. Explain the structure of MRP system with the help of block diagram. (08 Marks)

### Module-3

- 5 a. What are the benefits of Flexible Manufacturing System? (08 Marks)
- b. List out the advantages of Group Technology. (08 Marks)

OR

- 6 a. Explain in brief the different types of AS/RS systems. (06 Marks)
- b. The following data refers to the precedence relationship and element times for a New product.

Element No.	1	2	3	4	5	6	7	8	9	10	11	12
$T_c$ (min)	0.2	0.4	0.7	0.1	0.3	0.11	0.32	0.6	0.27	0.38	0.5	0.12
Precedence	-	-	1	1, 2	2	3	3	3, 4	6, 7, 8	5, 8	9, 10	11

Using Largest candidate rule method,

- (i) Construct the precedence diagram.
- (ii) If the ideal cycle time is 1.0 min find the number of work stations required.
- (iii) Balance delay and Balancy efficiency. (10 Marks)

**Module-4**

- 7 a. With the help of block diagram explain the elements of CNC system and highlight its advantages. (10 Marks)
- b. Write a part program for the following :  
- figure (drawing) - Peck drilling operation – Take drill dia 8 mm. [Refer Fig.Q7(b)]

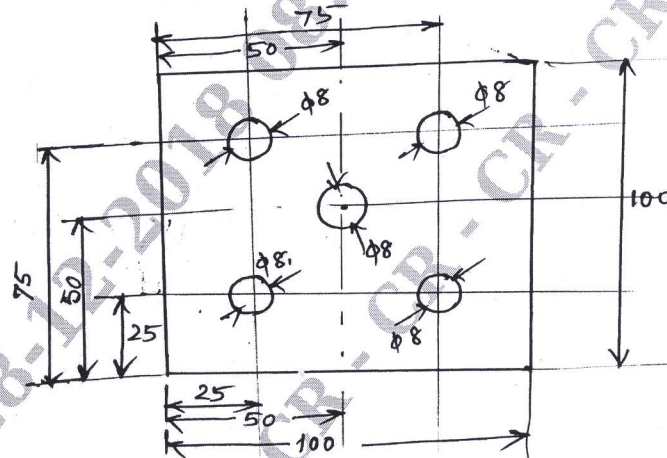

Note : All dimensions are in mm

Fig.Q7(b)

(06 Marks)

OR

**CMRIT LIBRARY**  
BANGALORE - 560 037

- 8 a. Define Industrial Robot. Explain the different configurations of a robot with neat sketches. (10 Marks)
- b. Explain the following Terminology related to robot.  
(i) Accuracy (ii) Resolution (iii) Repeatability. (06 Marks)

**Module-5**

- 9 a. What is additive manufacturing? Explain the different steps involved in preparing a component. (08 Marks)
- b. Explain the different powder Bed Fusion technique developed. (08 Marks)

OR

- 10 a. Explain in brief the various components of Industry 4.0. (10 Marks)
- b. Write a short note on Cloud computing. (06 Marks)

\*\*\*\*\*