

USN

--	--	--	--	--	--	--	--	--	--

10CV/CT73

Seventh Semester B.E. Degree Examination, Dec.2018/Jan.2019
Estimation and Valuation

Time: 3 hrs.

Max. Marks:100

Note: 1. Part – A Q.No. 1 which is compulsory, Answer any FOUR questions by Selecting any TWO from part B and TWO from part C each.
2. Missing data, if any, may be suitably assumed.

PART – A

- 1 Prepare a detailed estimate residential building in Fig.Q1(Refer page no.2) for the following items of work. Prepare on abstract of estimated cost.
- Earth work excavation for foundation in hand soil at Rs. 125/m³
 - CC 1 : 4 : 8 for foundation at rate Rs. 2800/m³
 - Size stone masonry for foundation in cm 1 : 8 and basement in cm 1 : 6 at rate
 - BBM for superstructure in cm 1 : 6 at the rate of Rs
 - Internal plastering in cm 1 : 6 for walls at rate of Rs. (40 Marks)

PART – B

- 2 Prepare a detailed estimate of a manhole from the given drawing Fig.Q2(Refer page no.3), work out the quantities and cost of the following terms of work.
- Earth work excavation for foundation at the rate of Rs.200/m³
 - CC 1 : 4 : 8 for foundation at rate Rs
 - First class brick work in cm 1 : 4 at rate of Rs. (15 Marks)
- 3 Write detailed specification of any three of following :
- Size stone masonry for foundation in cm 1 : 8
 - BBM for super structure in cm 1 : 6
 - 12mm ceiling plastering
 - Cement concrete 1 : 2 : 4 for plinth. (15 Marks)
- 4
- Enumerate various types of estimate. Explain any two in brief. (10 Marks)
 - “Estimate is never the actual cost but it is approximate cost” Explain briefly. (05 Marks)

PART – C

- 5 Workout form first principle, the rate analysis for any three of the following :
- Cement concrete 1 : 4 : 8 for foundation
 - BBM for super structure in cm 1 : 6
 - Size stone random rubble masonry for foundation in cm 1 : 8
 - CC 1 : 1½ : 3 for beams with 2% steel. (15 Marks)

- 6 Prepare the cost of earth work for a portion of road for 400 meter length from the following data :
- Formation width of road is 10mt
 - Side slopes are 2 : 1 in banking and $1\frac{1}{2}$: 1m cutting
 - The cost of filling is Rs. 250/m³ and cutting is Rs. 160/m³.

(15 Marks)

Station	Distance in mt	RL of ground	RL of formation
20	1000	51.00	52.00 ↓ Downward gradient of 1 in 200 ↓
21	1040	50.90	
22	1080	50.50	
23	1120	50.80	
24	1160	50.60	
25	1200	50.70	
26	1240	51.20	
27	1280	51.40	
28	1320	51.30	
29	1360	51.00	
30	1400	50.60	

- 7 Explain any three of the following :

- EMD
- Security deposited
- NMR
- Measurement Book
- Sinking Fund.

(15 Marks)

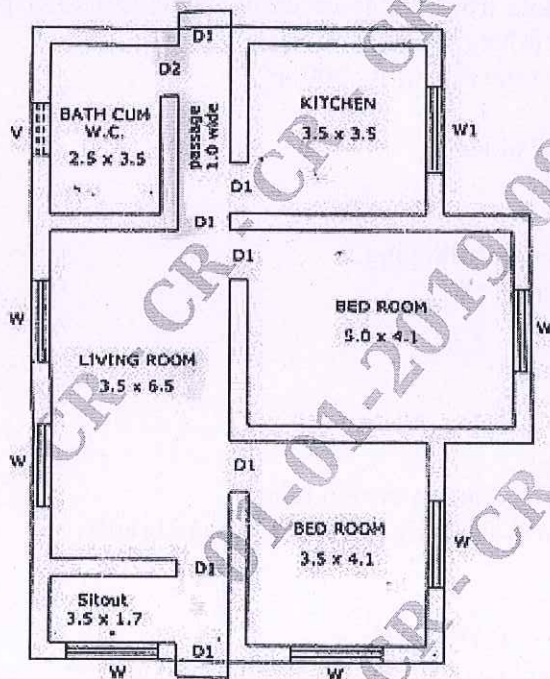

PLAN (not to scale)

ALL DIMENSIONS ARE IN METERS

A RESIDENTIAL BUILDING.

Fig : 1 (Q.No. 1)

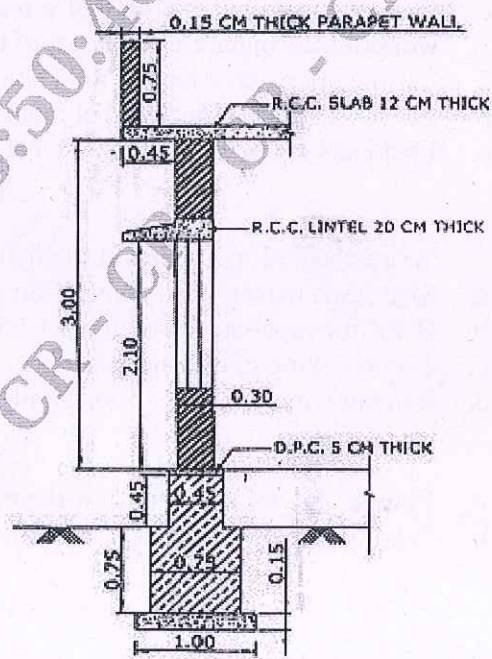

C/S OF WALL (enlarged)

SCHEDULE OF OPENINGS

DOOR : D1 - 1.20 X 2.10	WINDOW : W - 1.50 X 1.35
D2 - 0.90 X 2.10	W1 - 1.50 X 1.20
	VENTILATOR : V - 0.90 X 0.45

Fig.Q1
2 of 3

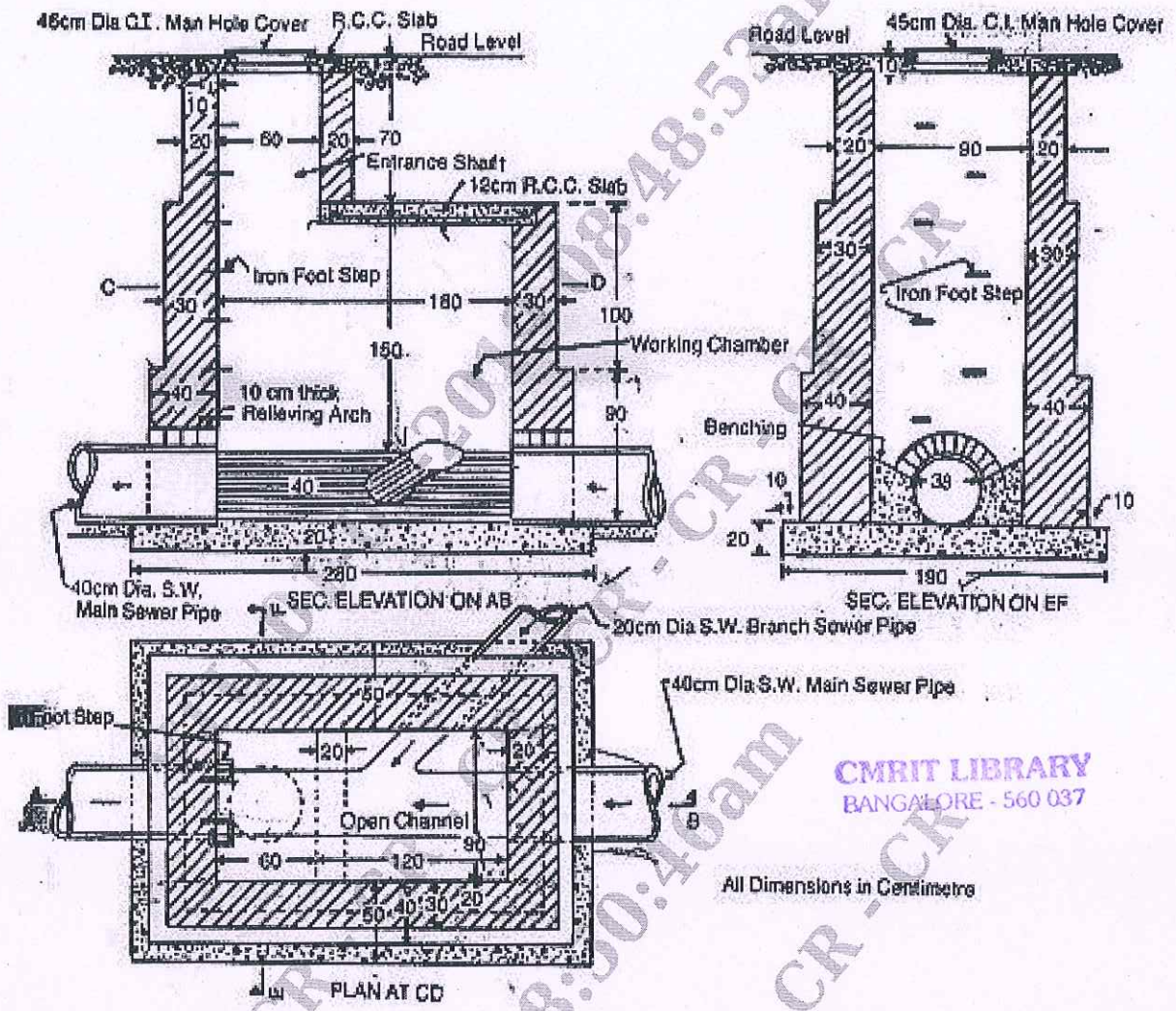

CMRIT LIBRARY
BANGALORE - 560 037

All Dimensions in Centimetres

Fig.Q2
