



Control Engineering

Time: 3 hrs.

Max. Marks:100

Note: Answer any FIVE full questions, selecting at least TWO questions from each part.

PART - A

- 1
 - a. What are requirements of an ideal control system? Explain them. (04 Marks)
 - b. Explain with suitable examples regulator system and follow-up system. (06 Marks)
 - c. Discuss, giving equations, the effect of following controller on the system:
 - i) Proportional plus derivative controller
 - ii) Proportional plus integral controller (10 Marks)
- 2
 - a. Obtain the transfer function of an armature controlled d.c. motor. (10 Marks)
 - b. Obtain step response of a first order thermal system. (05 Marks)
 - c. Writing Equivalent Analogous System for Force-voltage and Force-Current Analogy. (05 Marks)
- 3
 - a. Use block diagram reduction to obtain the overall transfer function of the system shown in Fig.Q3(a).

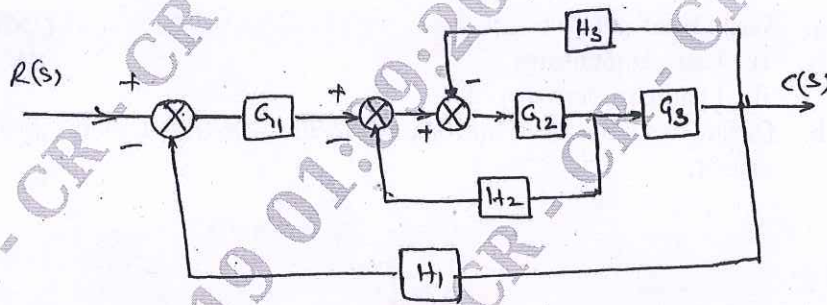

Fig.Q3(a)

(10 Marks)

- b. Obtain the closed loop transfer function $\frac{C(s)}{R(s)}$ for the signal flow graph of a system shown in Fig.Q3(b) by use of Mason's gain formula.

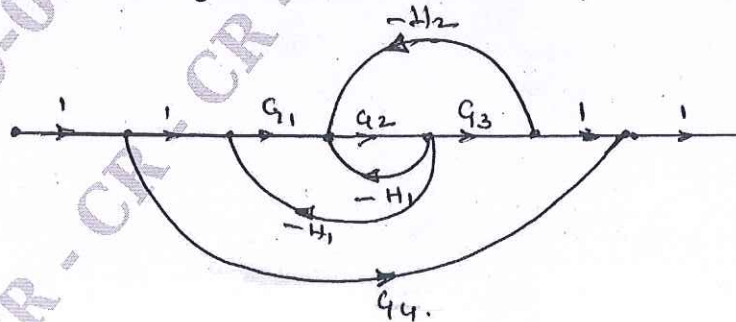

Fig.Q3(b)

(10 Marks)

Important Note : 1. On completing your answers, compulsorily draw diagonal cross lines on the remaining blank pages.
2. Any revealing of identification, appeal to evaluator and /or equations written eg, 42+8 = 50, will be treated as malpractice.

- 4 a. By applying Routh criterion, discuss the stability of the closed loop system whose characteristic equation is $s^6 + 3s^5 + 4s^4 + 6s^3 + 5s^2 + 3s + 2 = 0$. (06 Marks)
- b. Determine the rise time, peak time, peak overshoot, and setting time for the given transfer function $G(s) = \frac{16}{s(s+2)}$ subjected to unit step function. (08 Marks)
- c. Derive the response of a first order system, subjected to unit step function input. Explain the importance of time constant on speed of response. (06 Marks)

PART - B

- 5 a. Sketch the polar plot for $GH(s) = \frac{12}{s(s+2)(s+4)}$. (06 Marks)
- b. Sketch the Nyquist plot for $GH(s) = \frac{10}{s(s+6)(s+8)}$. (14 Marks)
- 6 Sketch the Bode plot of a unity feedback system whose open loop transfer function is given by $G(s) = \frac{20}{s(1+0.1s)(1+0.05s)(1+0.5s)}$ and ascertain its stability. Write gain margin and phase margin. (20 Marks)
- 7 Sketch the root locus plot of a unity feedback with an open loop transfer function $G(s) = \frac{K}{s(s+3)(s+5)}$, find the value of K for stable. (20 Marks)
- 8 a. Write brief note on :
i) Lag compensator
ii) Lead compensator (10 Marks)
- b. Define state variable and state transition matrix. List the properties of the state transition matrix. (10 Marks)

CMRIT LIBRARY
BANGALORE - 560 037
