

# CBCS Scheme

USN

--	--	--	--	--	--	--	--	--	--

**CMRIT LIBRARY**  
BANGALORE - 560 037

15CIV13/23

## First/Second Semester B.E. Degree Examination, June/July 2018 Elements of Civil Engineering and Engineering Mechanics

Time: 3 hrs.

Max. Marks: 80

**Note: Answer any FIVE full questions, choosing one full question from each module.**

### Module-1

- 1 a. Write a note on scope of water resources and irrigation engineering. (05 Marks)
- b. Write neat sketch with labels of a gravity dam and arch dam and explain their structural behaviour and functionality. (05 Marks)
- c. Explain with sketches, the principle of transmissibility and law of superposition. (06 Marks)

OR

- 2 a. Bring out comparison between flexible and rigid pavements highlighting their advantages and limitations. (05 Marks)
- b. What are different types of bridges? Explain any one type of bridge, with a neat sketch and label its parts. (05 Marks)
- c. Determine the moment of 1.6N force about the Pivot 'O' of the switch, shown in fig. Q2(c). (06 Marks)

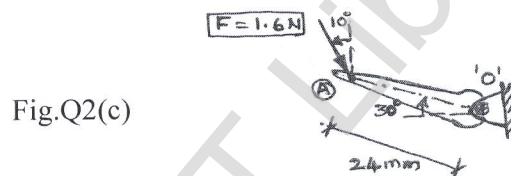

### Module-2

- 3 a. State and explain the laws of static friction. (06 Marks)
- b. A barge is pulled by two tug boats as shown in fig. Q3(b). If the resultant of the forces exerted by tug boats is 25kN directed along the axis of barge, determine i) Tension in each of ropes, knowing that  $\alpha = 45^\circ$  ii) The value of  $\alpha$  such that the tension is rope B is minimum. (10 Marks)



OR

- 4 a. State the law of Parallelogram of forces. (02 Marks)
- b. Cable AB passes over a small frictionless pulley 'C' as shown in fig.Q4(b). What length of cable CD is required for static equilibrium in the position shown? Also find the tension T in cable CD. (06 Marks)

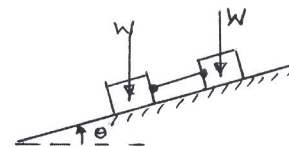
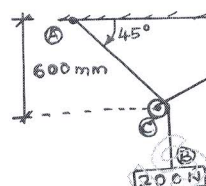

- c. Two blocks of equal weight rest on an inclined plane as shown in fig.Q4(c) and are connected by a string as shown. If the coefficient of friction of left side block and incline is  $\mu_1 = 0.2$  and that of other block and incline is  $\mu_2 = 0.3$ , find the angle of inclination of the plane for which sliding will be impending. Assume weight of each block  $W = 22.25N$ . (08 Marks)

**Module-3**

- 5 a. Explain different types of reactions from various supports. (04 Marks)  
 b. Explain and show how the moment of following loads are calculated with sketch :  
 i) Uniformly distributed load and ii) Uniformly varying load. (04 Marks)  
 c. Four forces act on a 700mm × 350mm plate  
 i) Find the resultant of these forces ii) Locate the point of intersection of the line of action of resultant with edge AB of the plate shown in fig. Q5(c). (08 Marks)

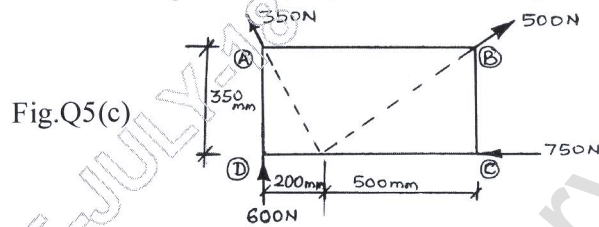

OR

- 6 a. State and prove Varignon's principle of Moments. (04 Marks)  
 b. Explain the equilibrium conditions for Co-planar non-concurrent force system. (04 Marks)  
 c. A beam AB 11m long is hinged at A and supported on rollers over a smooth inclined at 45° to horizontal at B. The beam is loaded as shown in fig. Q6(c). Determine the reactions at A and B. (08 Marks)

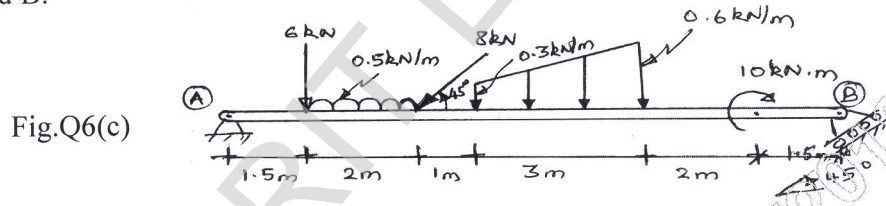

**Module-4**

- 7 a. State and prove parallel axis theorem. (06 Marks)  
 b. Determine the centroid for the shaded area shown in fig. Q7(b), with respect to 'O'. (10 Marks)

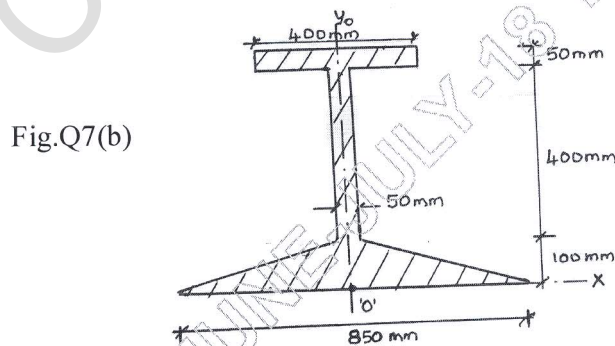

OR

- 8 a. Determine the centroid of the semi circular area of radius R with diametrical base placed along horizontal by first principle. (04 Marks)

- b. Determine moment of inertia of shaded area shown in fig. Q8(b) with respect to X & Y axis. Also determine radius of gyration. (12 Marks)

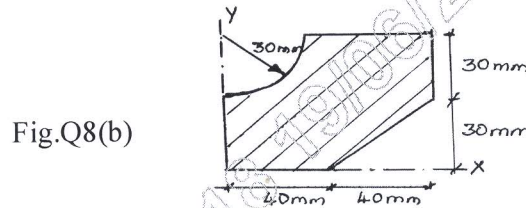

**Module-5**

- 9 a. State Newton's laws of motion. (03 Marks)  
 b. Explain the term Super Elevation. (03 Marks)  
 c. A stone is dropped into a well and falls vertical with constant acceleration of  $g = 9.81 \text{ m/s}^2$ . The sound of impact of stone on bottom of well is heard 6.5 seconds after it is dropped. If the velocity of sound is 336m/s, how deep is the well? (10 Marks)

OR

- 10 a. Explain the terms i) Displacement ii) Velocity iii) Acceleration. (06 Marks)  
 b. Two adjacent guns having the same velocity  $V_0 = 300 \text{ m/s}$  fire simultaneously at angles of elevation  $\alpha_1$  and  $\alpha_2$  with horizontal for the target at same range ,  $r = 4500\text{m}$ . Calculate the time difference  $t_2 - t_1$  between the two hits. (10 Marks)