

USN

--	--	--	--	--	--	--	--

18CIV14/24

## First/Second Semester B.E. Degree Examination, June/July 2019 Elements of Civil Engineering and Mechanics

Time: 3 hrs.

Max. Marks: 100

**Note:** 1. Answer any FIVE full questions, choosing ONE full question from each module.  
2. Assume missing data suitably.

### Module-1

1. a. Briefly explain the role of civil engineers in the infrastructure development of the country. (06 Marks)
- b. Explain briefly the scope of civil engineering in (i) structural engineering (ii) geotechnical engineering. (08 Marks)
- c. A 200 N vertical force is applied to the end of the lever which is attached to a shaft as shown in Fig.Q1(c). Determine: (i) Moment of force about 'O' (ii) Horizontal force applied at 'A' which creates same moment about 'O' (iii) Minimum force which creates the same moment about 'O'.

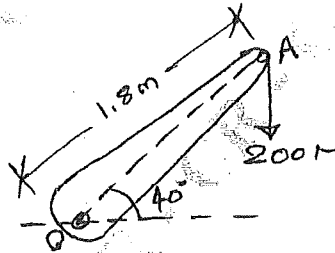

Fig.Q1(c)

(06 Marks)

OR

2. a. Determine the resultant of the force system acting on a body as shown in the Fig.Q2(a) with respect to point 'O'.

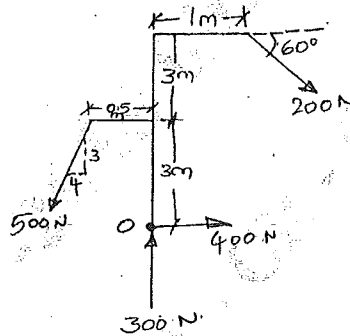

Fig.Q2(a)

(08 Marks)

- b. State and prove Varignon's theorem of moments. (06 Marks)
- c. 2 kN force is the resultant of a system of forces acting along positive y-axis as shown in Fig.Q2(c). Determine the value of F and  $\theta$ .

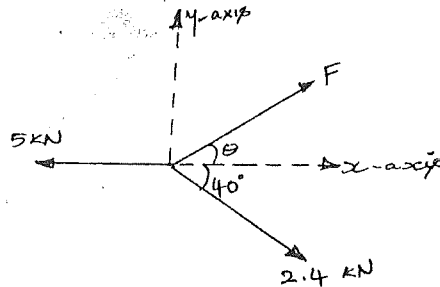

Fig.Q2(c)

(06 Marks)

Important Note: 1. On completing your answers, compulsorily draw diagonal cross lines on the remaining blank pages.  
2. Any revealing of identification, appeal to evaluator and /or equations written eg, 42+8 = 50, will be treated as malpractice.

**Module-2**

- 3 a. What is meant by equilibrium? State the conditions of static equilibrium for both coplanar concurrent and non-concurrent force system. (05 Marks)
- b. State and prove Lami's theorem. (05 Marks)
- c. Determine the force 'P' required to cause the motion of the blocks to impend. Take the weight of A as 90 N and weight of B as 50 N. Take coefficient of friction for all contact surfaces as 0.30 as shown in Fig.Q3(c) and consider the pulley being frictionless.

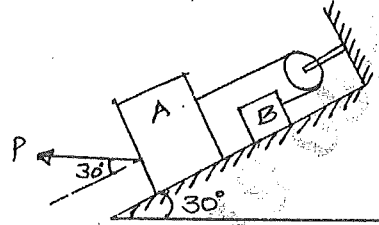

Fig.Q3(c) (10 Marks)

OR

- 4 a. Briefly explain: (i) Angle of friction (ii) Cone of friction. (04 Marks)
- b. Calculate the tension in the strings. Also calculate ' $\theta$ ' in Fig.Q4(b).

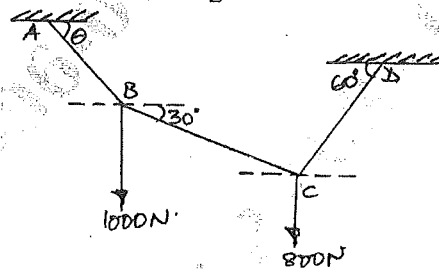

Fig.Q4(b) (10 Marks)

- c. Prove that angle of repose is equal to angle of friction. (06 Marks)

**Module-3**

- 5 a. What are the different types of beams? How do you differentiate them? (06 Marks)
- b. List the steps followed in the analysis of truss by method of joints. (06 Marks)
- c. Find the length 'X' so that the reactions at both the supports are equal for the beam as shown in Fig.Q5(c).

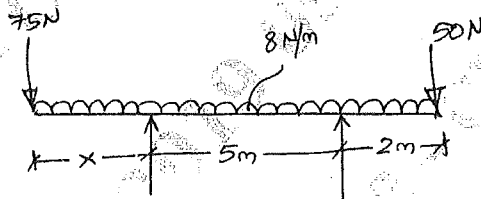

Fig.Q5(c) (08 Marks)

OR

- 6 a. List the assumptions made in the analysis of trusses. (04 Marks)
- b. What are the different types of supports and mark their reaction lines. (06 Marks)
- c. Analyze the frame and tabulate the member forces for the frame shown in Fig.Q6(c).

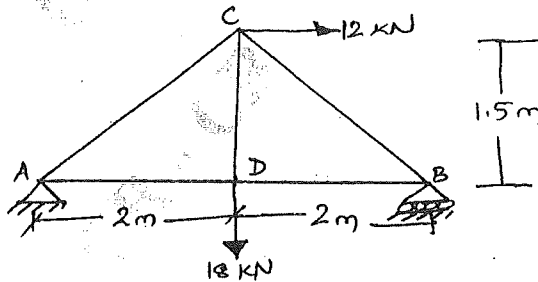

Fig.Q6(c) (10 Marks)

**Module-4**

- 7 a. Derive an expression for the centroid of a right angles triangle. (06 Marks)  
 b. State and prove perpendicular axis theorem. (04 Marks)  
 c. Determine the polar radius of gyration for the built up section as shown in Fig.Q7(c).

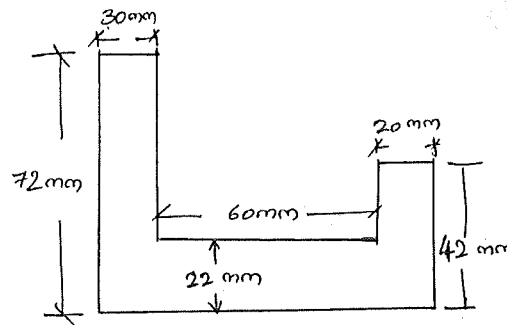

Fig.Q7(c) (10 Marks)

OR

- 8 a. Determine the moment of inertia of a semicircle with respect to its diameter line and hence determine the moment of inertia with respect to its centroidal axis parallel to the diameter line. Also write the expression for moment of inertia with respect to a line perpendicular to the diameter passing through the centroid. (12 Marks)  
 b. Determine the position of the centroid for the Fig.Q8(b).

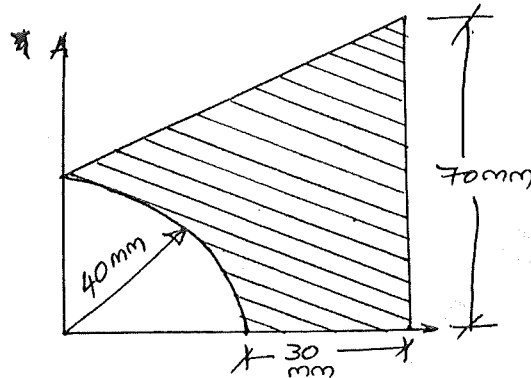

Fig.Q8(b) (08 Marks)

**Module-5**

- 9 a. Define displacement, distance travelled, velocity and acceleration. Mention their respective S.I. units. (04 Marks)  
 b. Acceleration of a particle is given by  $a = -2 \text{ m/s}^2$ . If  $v = 8 \text{ m/s}$  and  $x = 0$  when  $t = 0$ . Determine: (i) velocity (ii) total distance travelled when  $t = 6 \text{ sec}$ . (08 Marks)  
 c. State D'Alembert's principle and mention its application in plane motion. (08 Marks)

OR

- 10 a. Derive the equations of motion. (08 Marks)  
 b. What is superelevation? Why is it necessary? (04 Marks)  
 c. An aircraft moving horizontally at a speed of 300 km/hr at an elevation of 2.5 km targets a point on the ground and releases a bomb. If the bomb has to hit the target, determine the horizontal distance at which the aircraft should release the bomb. Also calculate the velocity and direction with which the bomb will hit the target. (08 Marks)

\*\*\*\*\*

