

USN

--	--	--	--	--	--	--	--	--	--

10CV33

Third Semester B.E. Degree Examination, June/July 2016
Strength of Materials

Time: 3 hrs.

Max. Marks:100

Note: Answer any FIVE full questions, selecting atleast TWO questions from each part.

PART – A

- 1 a. Draw the stress versus strain curve for mild steel specimen subjected to axial tension and indicate the salient points. (05 Marks)
- b. Derive an expression for the deformation of the tapering circular bar subjected to an axial force P. Use standard notations. (08 Marks)
- c. The bar shown in fig. Q1(c) is tested in a universal testing machine. It is observed that at a load of 40kN the total extension is 0.285mm. Determine the Young's modulus of the material. (07 Marks)

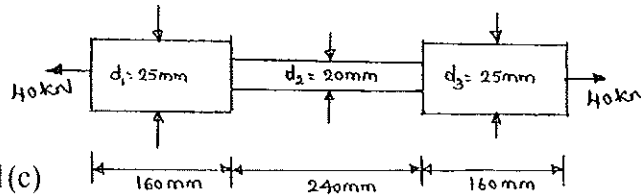
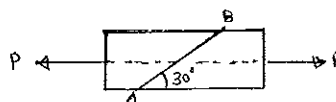

Fig.Q1(c)

- 2 a. Derive relation between Modulus of Rigidity, Young's modulus and Poisson's ratio. (06 Marks)
- b. A steel rod is of 20m long at a temperature of 20°C. Find the free expansion of the bar, when the temperature is raised to 65°C. Also calculate the temperature stress produced for the following cases : i) When the expansion of the rod is prevented ii) When the rod is permitted to expand by 5.8mm. Take $\alpha = 12 \times 10^{-6}/^{\circ}\text{C}$ and $E = 200 \text{ GPa}$. (06 Marks)
- c. A load of 2MN is applied on a column 500mm × 500mm. the column is reinforced with four steel bars of 10mm diameter, one in each corner. Find the stresses in the concrete and steel bars. Take E for steel as $2.1 \times 10^5 \text{ N/mm}^2$ and for concrete as $1.4 \times 10^4 \text{ N/mm}^2$. (08 Marks)
- 3 a. Define : i) Principal plane ii) Principal stresses. (04 Marks)
- b. Determine the magnitude and direction of resultant stresses on a plane inclined at an angle of 60° to major principal stress plane, when the bar is subjected to principal stresses at a point 200MPa tensile and 100MPa compressive. Also determine the resultant stress and its obliquity. (06 Marks)
- c. Two wooden pieces 100mm × 100mm in cross section are glued together along line AB as shown in fig. Q3(c). What maximum axial force 'P' can be applied if the allowable shearing stress along AB is 1.2 N/mm^2 ? (10 Marks)

Fig.Q3(c)



- 4 a. Define i) Bending moment ii) Point of contraflexure. (04 Marks)
- b. For the cantilever beam shown in fig. Q4(b), obtain SFD and BMD. (06 Marks)

Fig.Q4(b)

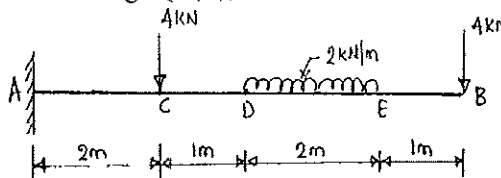

Important Note : 1. On completing your answers, compulsorily draw diagonal cross lines on the remaining blank pages.
 2. Any revealing of identification, appeal to evaluator and or equations written e.g. 42-8 = 50, will be treated as malpractice.

- c. Draw the Shear force and Bending moment diagrams for the beam shown in fig. Q4(c).
(10 Marks)

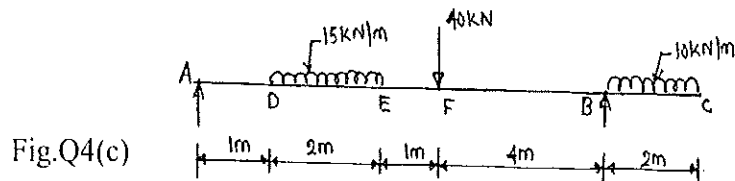

PART – B

- 5 a. Derive the equation of theory of simple bending with usual notations. (06 Marks)
 b. A simply supported beam of span 6m has a cross section as shown in fig. Q5(b), it carries two point loads each of 30kN at a distance of 2m from each support. Calculate the bending stress and shear stress for maximum values of bending moment and shear force respectively. Draw neat diagram of bending stress and shear stress distribution across the cross section. (14 Marks)

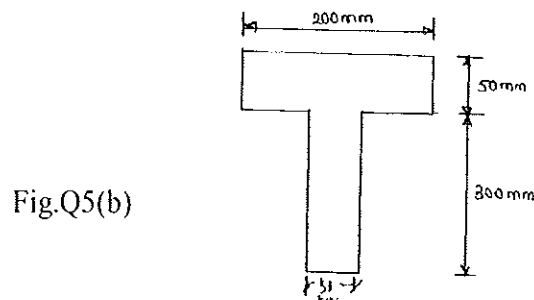

- 6 a. Explain the terms : i) Slope ii) Deflection iii) Deflection curve. (06 Marks)
 b. A simply supported beam 8m long, carries two concentrated loads of 80kN and 60kN at distances of 3m and 6m from left end support respectively. Calculate slope and deflection under loads. Given $E = 2.0 \times 10^5$ MPa and $I = 300 \times 10^6$ mm⁴. (14 Marks)
- 7 a. State the assumptions made in the theory of Pure Torsion. (04 Marks)
 b. A hollow shaft of internal diameter 400mm and external diameter 460mm is required to transmit power at 180rpm. Determine the power it can transmit, if the shear stress is not to exceed 60N/mm² and the maximum torque exceeds the mean by 30%. (06 Marks)
 c. A solid circular shaft is to transmit 250kW at 100 rpm. If the shear stress is not to exceed 75N/mm², what should be the diameter of the shaft? If this shaft is to be replaced by a hollow one, whose internal diameter is 0.6 times external diameter, determine the size and percentage saving in weight, maximum shear stress being the same. (10 Marks)
- 8 a. Derive an expression for Euler's crippling load for a column with both ends fixed. (08 Marks)
 b. Compare the crippling loads given by Euler's and Rankine's formula for a column of circular section 2.3m long and of 30mm diameter. The column is hinged at both ends. Take yield stress as 335N/mm² and Rankine's constant $\alpha = \frac{1}{7500}$ and $E = 2 \times 10^5$ N/mm². For what ratio of L/K, the Euler's formula cease to apply for this column? (12 Marks)