

Solutions

**CMR
INSTITUTE OF
TECHNOLOGY**



Sub:	Engineering Chemistry				Code:	18CHE12			
Date:	19/09/2019	Duration:	90 mins	Max Marks:	50	Sem:	I	Branch:	All

Internal Assessment Test I

1. (a) What is single electrode potential? Derive the Nernst equation for single electrode potential. (06 Marks) (CO1, L3)

Solution: Single Electrode Potential: Electrode potential is defined as the potential developed at the interface between metal and solution, when it is in contact with solutions of its ions.

Or

It is a measure of the tendency of the metal electrode to lose or gain electrons, when it is in contact with its own ionic solution. It is represented as **E**.

Nernst Equation

In 1889, Nernst derived a quantitative relationship between electrode potential and concentration of electrolyte species. According to thermodynamics, decrease in free energy (-) represents maximum amount of work that can be obtained from a chemical reaction.

$$= W_{\max} \text{----- (1)}$$

Work done in electrochemical reaction depends on

- (i) Number of coulombs that flow
- (ii) Energy available per coulomb.

Number of coulombs = $n \times F$

Where n = number of electrons involved in the cell reaction

F = Faraday

Energy available per coulomb = E_{cell} (V)

$$1V = 1 \text{ JC}^{-1}$$

When E_{cell} = maximum, work derived from cell is maximum.

Thus, ----- (2)

n = moles of electrons, $F = \text{Cmol}^{-1}$, $E = \text{JC}^{-1}$

Equating equations (1) & (2)

$$- = n \times F \times E$$

$$= - n \times F \times E \text{----- (3)}$$

Under standard conditions, when concentrations of all species is unity, standard free energy change is given by equation

$$n \times F \times E^{\circ} \text{----- (4)}$$

Where E° is a constant called standard electrode potential.

Consider the reduction reaction

The equilibrium constant () is related to change in free energy by equation

$$= \Delta G^{\circ} + RT \ln \text{----- (5)}$$

$$= \text{----- (6)}$$

Therefore by substituting values of ΔG , ΔG° and K from equation (3), (4) and (6) into equation (5), we get

$$-nFE = -nFE^{\circ} + RT \ln$$

$$-nFE = -nF E^\circ + RT \ln [M] - RT \ln [Mn+]$$

Dividing whole equation by $-nF$

=

$$E = E^\circ -$$

Assume $[M] = 1, \ln 1 = 0$

$$E = E^\circ + \text{-----} (7)$$

Substituting the values for R (8.314 JK⁻¹mol⁻¹), F (96500Cmol⁻¹), T (298K) and converting natural log to base 10 in eqn (7) we get

$$E = E^\circ +$$

This is the mathematical representation of Nernst equation.

(b) Discuss secondary and reserve batteries with examples. (04 Marks) (CO1, L2)

Solution:

Secondary batteries: In secondary batteries, the net cell reaction is completely reversible and hence these are rechargeable. For example: Lead storage battery, Ni – Cd battery etc.

Reserve batteries: One of the key components i.e. electrolyte, in reserve batteries is incorporated into the battery when required. When one of the key components is separated from remainder, chemical reaction between cell components (self discharge) is prevented and battery can be stored for a long period of time. For example: Mg-AgCl, Mg-CuCl, Zinc – Silver oxide reserve batteries, etc.

2. (a) What are concentration cell? Emf of the cell Cd/CdSO₄(XM)//CdSO₄(0.035M)/Cd at 30C is 0.035 V. Find the concentration of CdSO₄ at anode and write the cell reactions. Given, R=8.314J/K/mol, F=96500C/mol. (05 Marks) (CO1, L3)

Solution: T=30C=303K,

$$E_{\text{cell}} = 2.303RT/nF \log C_2/C_1$$

Where C_2 = Concentration of electrolyte at cathodic compartment = 0.035 M

C_1 = Concentration of electrolyte at anodic compartment = XM

$$E = 0.035V$$

$$n = 2$$

Substituting the above values in above formula,

$$0.035 = (2.303 \times 8.314 \times 303) / 2 \times 96500 \log 0.035/X$$

$$0.035 = 0.0300 [\log 0.035 - \log X]$$

$$1.167 = [\log 0.035 - \log X]$$

$$1.167 = -1.455 - \log X$$

$$\log x = -2.622$$

$$x = 0.0023M$$

Thus, the value of $x = 0.0023M$.

Cell Reaction

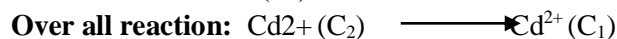
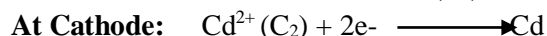
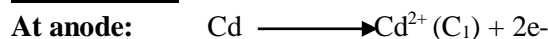

(b) Describe the construction and working of Ni-MH battery. Mention its applications. (05 Marks) (CO1, L2)

Solution: Nickel-Metal Hydride Battery: It is a good example for secondary battery which is also called as rechargeable battery.

Construction:

1. Anodic material - Metal hydride such as VH₂, ZrH₂, TiH₂ etc with a hydrogen storage alloy such as LaNi₅, TiZr₂ etc. Anodic

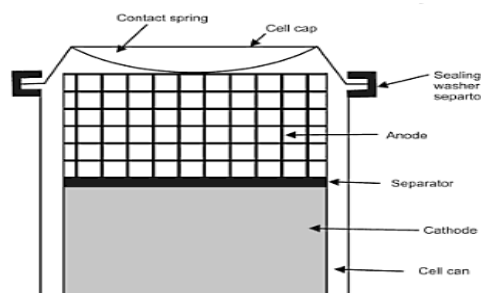

Fig. : Nickel – metal hydride battery

material permits reversible electrochemical storage and release of hydrogen (H₂) during charging and discharging of battery and is corrosion resistant.

2. Cathodic material – NiO(OH) nickel oxy hydroxide. (Highly porous Ni substrate into which Ni(O)OH is impregnated.

3. Electrode – Porous nickel foil/grid on to which active materials are either coated or pasted.

4. Electrolyte – Aqueous solution of KOH (30%).

5. Separator – Synthetic non – woven polypropylene is used, it serves the purpose of separator as well as electrolyte absorbent.

Cell Representation

The battery is represented as, MH₂ /KOH (30%) / Ni (OH)₂, NiO(OH)

Working:

The cell reactions occurring during discharging (→) and recharge (←) are,

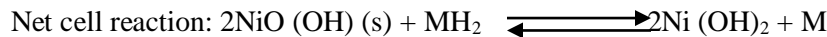
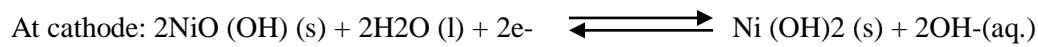
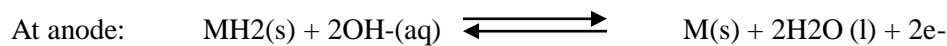

During discharging process, at anode MH₂ reduces to M & at cathode Ni³⁺ reduces to Ni²⁺. Finally the battery produces a potential of 1.35V.

Applications: Ni-MH battery is used in,

1. Electric razors, toothbrushes, cameras, pagers, cellular phones and laptop computer

2. Medical instruments and equipments and also used in automotive batteries.

3. (a) What are ion selective electrodes? Explain the determination of pH of unknown solution using glass electrode. (05 Marks) (CO1, L4)

Solution:

Ion Selective electrodes: These are the electrodes, which responds to specific ions only and develops a potential against that ions while ignoring the other ions present in the solution.

Determination of pH using glass electrode or calomel electrode

To determine the pH of given solution, glass electrode is dipped in a solution whose pH has to be determined. It is combined with a saturated calomel electrode through a salt bridge.

Cell assembly representation:

Hg / Hg₂Cl₂ / Cl⁻ // Unknown solution / glass membrane / 0.1N HCl / AgCl / Ag

From the EMF, the pH of the solution is calculated as below:

$$E_{\text{cell}} = E_{\text{right}} - E_{\text{left}}$$

$$E_{\text{cell}} = E_{\text{glass}} - E_{\text{cal}}$$

$$E_{\text{cell}} = (E^{\circ}_{\text{G}} - 0.0591 \text{ pH}) - E_{\text{cal}}$$

$$E_{\text{cell}} = E^{\circ}_{\text{G}} - 0.0591 \text{ pH} - E_{\text{cal}}$$

$$\text{pH} = (E^{\circ}_{\text{G}} - E_{\text{cal}} - E_{\text{cell}}) / 0.0591$$

$$\text{pH} = (K - E_{\text{cell}}) / 0.0591 \quad K = (E^{\circ}_{\text{G}} - E_{\text{cal}})$$

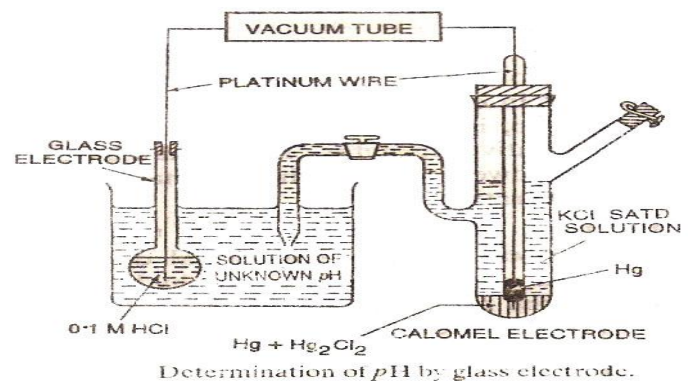

(b) Discuss the construction and working of Li-ion battery. Mention its applications. (05 Marks) (CO1, L2)

Solution: Battery is a device consisting of two or more galvanic cells arranged in series or parallel or both, that can generate electrical energy.

A lithium-ion battery is a secondary battery in which lithium ions move from the negative electrode to the positive electrode during discharge and back when charging.

Anode: Li-metal oxide, like lithium cobalt oxide

Cathode: Carbon (graphite)

Electrolyte: Lithium salts (LiCl, LiBr) in organic carbonate solvents (ethylene carbonate)

Separator: Polypropylene separator

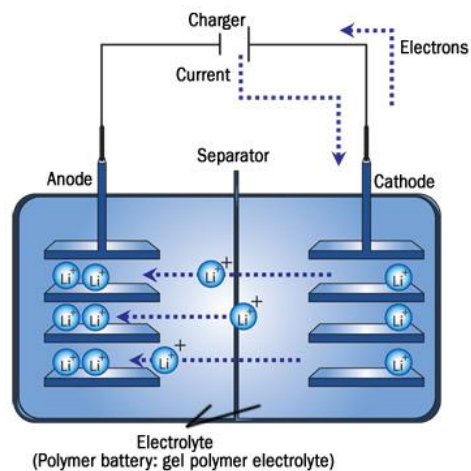

Fig. : Lithium Ion battery

Cell representation

The battery is represented as, $\text{LiMO}_2 / \text{electrolyte (lithium salt in an organic solvent)} / \text{C (graphite)}$

Working:

The positive electrode half-reaction is:

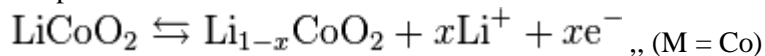

The negative electrode half reaction is:

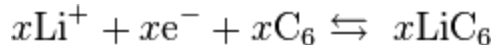

The overall reaction has its limits. Over discharge supersaturates lithium cobalt oxide, leading to the production of lithium oxide, possibly by the following irreversible reaction:

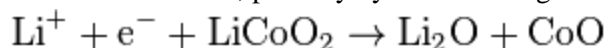

Applications: Li-ion battery is used in

1. Portable devices like mobile phones and smartphones, laptops and tablets, digital cameras and camcorders, electronic cigarettes, handheld game consoles and torches (flashlights).
2. Li-ion batteries are used in tools such as cordless drills, sanders, saws
3. Electric vehicles.
4. Li-ion batteries are used in telecommunications applications.

4. (a) For the cell, $\text{Cu}/\text{CuSO}_4(0.05\text{M})//\text{AgNO}_3(0.25\text{M})/\text{Ag}$, write the cell reaction and calculate the emf of cell at 298K, if standard potentials of Cu and Ag electrodes are +0.34V and +0.8V respectively. (05 Marks) (CO1, L3)

Solution: $\text{Cu}/\text{CuSO}_4(0.05\text{M})//\text{AgNO}_3(0.25\text{M})/\text{Ag}$

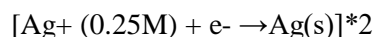
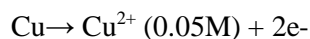

The Nernst equation is:

$$E_{\text{cell}} = E^{\circ}_{\text{cell}} + 0.0592/n \log \text{cathode}/\text{anode}$$

$$E_{\text{cell}} = E^{\circ}_{\text{cell}} + 0.0592/2 \log [Ag^+]^2/[Cu^{2+}]$$

$$E_{\text{cell}} = E^{\circ}_{\text{Cathode}} - E^{\circ}_{\text{Anode}}$$

$$E_{\text{cell}} = 0.80 - 0.34$$

$$E_{\text{cell}} = 0.46V$$

$$E_{\text{cell}} = 0.46 + 0.0295 \log (0.05)^2/0.25$$

$$E_{\text{cell}} = 0.46 + 0.0295 \log (0.0025)/(0.25)$$

$$E_{\text{cell}} = 0.4305V$$

b. What are reference electrodes? Explain the construction and working of calomel electrode. (05 Marks) (CO1, L4)

Solution: Reference Electrodes: These are the electrodes, used to determine the potentials of unknown electrodes. They are of two types;

I. Primary Reference Electrodes: These are the electrodes whose potentials are known from the method of construction. Eg. Standard hydrogen electrode (SHE).

II. Secondary Reference Electrodes: These are the electrode whose potential is known or constant and stable does not vary with temperature. E.g.: Calomel electrode

Calomel electrode: It is a metal -**metal insoluble salt electrode** is also called as secondary reference electrode.

Construction: Electrode consists of glass tube. The bottom of the glass tube is filled with pure mercury (Hg) on which a calomel paste ($Hg + Hg_2Cl_2$) is placed. The remaining part of the glass tube is filled with sat. or std KCl Solution. It also contains side tube serves as salt bridge and a platinum wire is dipped into the mercury so that it serves as electrical contact.

Half cell representation: The calomel electrode is represented as, $KCl/HgCl_2, Hg$

Half cell reactions:

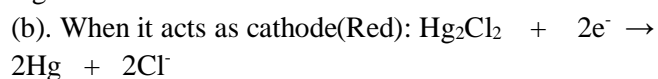
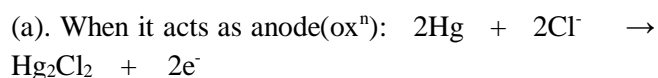

The electrode potential of the calomel electrode is mainly depends on the concentration of KCl used, Electrode potential is calculated using Nernst equation,

$$E = E^{\circ} - \frac{2.303RT \log[Cl^-]}{F}$$

For,	0.344V	for	[KCl] = 0.1N
	0.281V	for	[KCl] = 1.0N
	0.2422V	for	[KCl] = saturated KCl

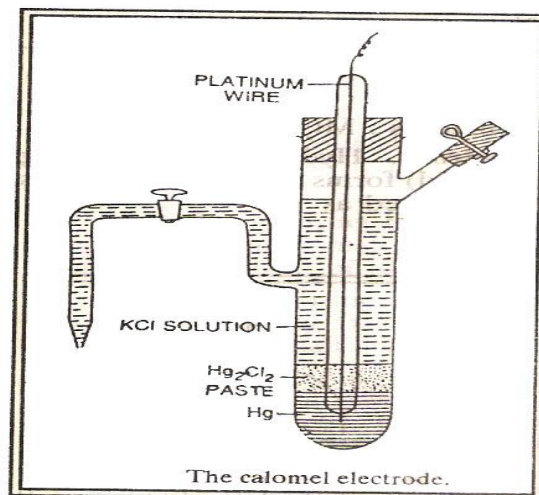

5. (a) Define corrosion? Illustrate the Electro-chemical theory of corrosion taking the iron as an example. (06 Marks) (CO2, L3)

Solution: Corrosion: It is defined as the destruction of metal or alloys by the surrounding environment through chemical or electrochemical changes.

Electrochemical theory of corrosion: Most of the corrosion problems are best explained on the basis of electrochemical theory.

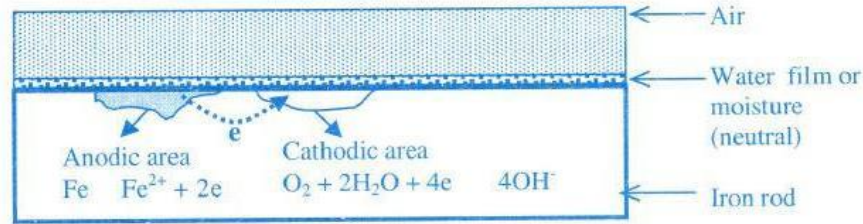

(i) According to electrochemical theory, corrosion of metals takes place due to the formation of minute galvanic cells over the surface of metal. Thus anodic and cathodic regions are formed on the same metal surface or when two metals are in contact with each other in the presence of a conducting medium.

(ii) At the anodic region oxidation reaction takes place and the **metal gets converted into its ions by liberating electrons**. Consequently, **metal undergoes corrosion at the anodic region**.

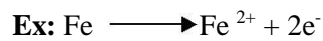

(iii) The electrons flow from the anodic to cathodic area and at the cathodic region, reduction takes place. Since metal cannot be reduced further, **metal atoms at the cathodic region are unaffected by the cathodic reaction**. Some constituents of the corrosion medium take part in the cathodic reaction. There are three possible ways in which the reduction can take place.

(i) If the solution is aerated and almost neutral, oxygen is reduced in presence of water to OH^- ions according to the equation.

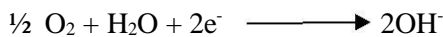

(ii) If the solution is deaerated and almost neutral the cathodic reaction involves formation of hydroxyl ions with evolution of hydrogen gas.

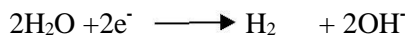

(iii) If the solution is deaerated and acidic, the H^+ ions are reduced to H_2

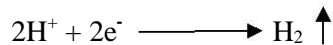

(iv) The electrons liberated at the anodic region migrates to the cathodic region constituting corrosion current, the metal ions liberated at the anode and some anions liberated at the cathode diffuse towards each other through the conducting medium-range and form a corrosion products.

Corrosion of iron produced Fe^{2+} ions and OH^- ions at the anode and cathode sites respectively. These ions diffuse towards each other and produce insoluble $Fe(OH)_2$.



In an oxidizing environment, it is oxidized to ferric oxide and the rust is hydrated ferric oxide.

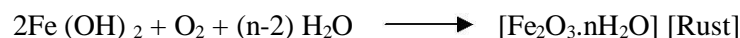

(b) What is metal finishing? Highlight any three technological importance of metal finishing. (04 Marks) (CO2, L1)

Solution: Process of surface modification by way of deposition of another metal or metal alloy or polymer or ceramic or oxide layer to bring about intended better surface characteristics is known as metal finishing.

Technological significance of metal finishing refers to imparting following different characteristics:

- (i) Better corrosion resistance,
- (ii) Better hardness, strength, wear / abrasion resistance, etc.
- (iii) Better thermal conductance or resistance or reflectance, etc.

6. (a) Explain the following types of corrosion (i) Differential metallic corrosion & (ii) Pitting corrosion. (04 Marks) (CO2, L4)

Solution: (1) Differential metallic corrosion [galvanic corrosion]

(i) When two dissimilar metals are in contact with each other, a potential difference is set up resulting in a galvanic current.

(ii) A metal placed high in the electrochemical series is said to be anodic with respect to the one placed below it.

Ex: Fe is anodic to Cu, Ni, and Sn (tin) (since E.P of Fe is -0.44V & Cu is +0.34V)

Fe acts as cathode when it is in contact with Zn, Mg. (since E.P of Zn is -0.76V & Mg is -2.37V)

Fe corrodes when it is in contact with Cu and Ni; but Zn and Mg corrode when these are in contact with Fe.

(iii) The rate of differential metal corrosion depends primarily on the amount of the current passing from anode to cathode i.e.; on the difference in electrochemical potential, higher the difference faster is the rate of corrosion.

Ex: (i) When iron and copper are in contact with an aerated solution of NaCl. A current flows between the two electrodes spontaneously and electrons flow from Fe to Cu, indicating that Fe is the anode and Cu is the cathode. The reaction that takes place is same as the reaction discussed under electrochemical theory.

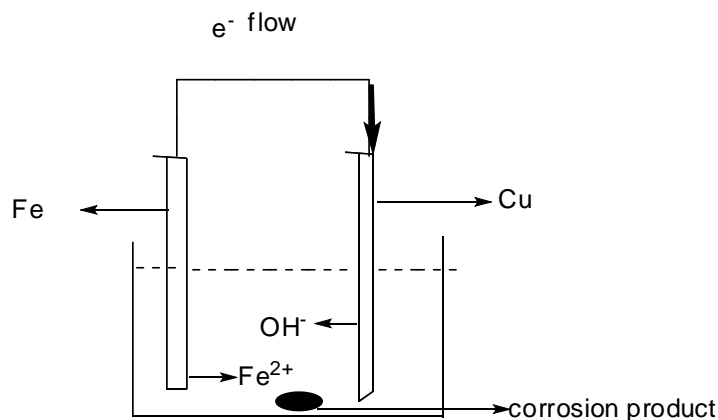

Ex: (ii) Combination of iron with copper metal

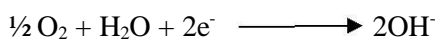

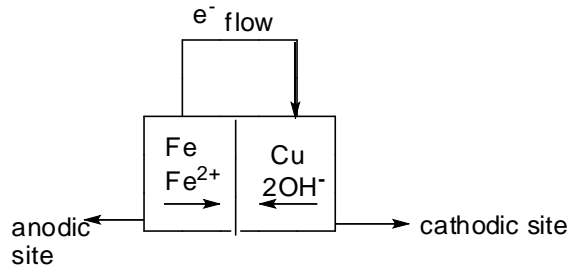
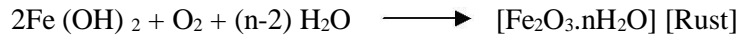

Ex: (iii) Combination of iron with zinc metal

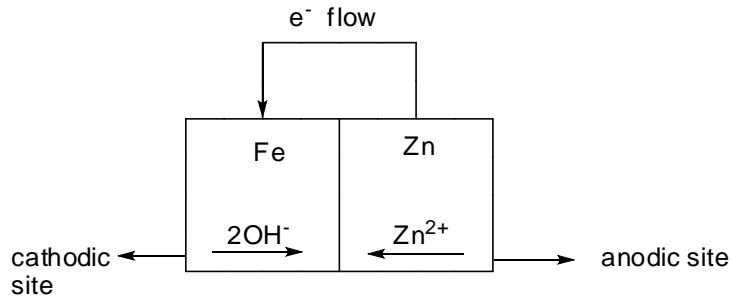

(2) Pitting Corrosion:

(i) Pitting corrosion results when small particles of dust get deposited on a steel surface. The portion covered by the dust will not be well aerated compared to the exposed surface.

(ii) The covered portion thus becomes anodic with respect to the surface exposed. In the presence of electrolyte and moisture corrosion takes place in the form of pits thereby increasing the rate of corrosion because of formation of small anodic area.

Ex: Crack developed in tin coating on iron gives rise to a small anodic area and large cathodic area.

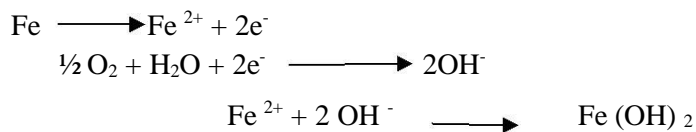

(b) What is electroplating? Describe the process of electroplating of chromium. (06 marks) (CO2, L2)

Solution: Electroplating: The process of deposition of a thin and uniform layer of metal or metal-alloy on to the electrically conducting object surface by electrolysis is known as electroplating.

Electroplating of Chromium:

Chromium is employed for either decorative purposes (as a thinner coat) or engineering purposes (as a thicker hard coat). Mentioned below are coating specifications.

- Active chromium anode is not used because, the anode efficiency is nearly 100% and that of the cathode is only around 20% at the best. There will be increase in concentration of Cr^{3+} ions which results in poor quality electrodeposits (black deposits).
- A thin coating of chromium is porous and thicker coating leads to cracking. Therefore, Cr-plating over steel is applied with an undercoat of copper and nickel. Copper is known to offer better finishing. Coverage of nickel and hence chromium is better with copper below. Also, lower thickness of nickel can be opted with an undercoat of copper. Chromium gives decorative & pleasing finish, nickel offers corrosion resistance and copper extends good coverage and better adhesion.

Bath composition	CrO_3 (chromic acid) : $\text{H}_2\text{SO}_4 = 100: 1$ ratio
Temperature	45 – 60 °C
Current density	100 – 200 mA/cm ²
Current efficiency	17 – 21 %
Anode material	Insoluble lead- Pb-Sb alloy or Pb-Sn alloy (with lead oxide coating)
Cathode material	Surface cleaned object metal
Reaction at anode	$\text{H}_2\text{O} \longrightarrow \frac{1}{2} \text{O}_2 \uparrow + 2\text{H}^+ + 2\text{e}^-$
Reaction at cathode	$\text{Cr}^{3+} + 3\text{e}^- \longrightarrow \text{Cr}$

- There is a complex sequence of reactions which control the concentration of Cr^{3+} in the plating bath. Sulfate ion is said to catalyse the conversion of Cr^{6+} into Cr^{3+} and PbO_2 catalyses the conversion of Cr^{3+} into Cr^{6+} .

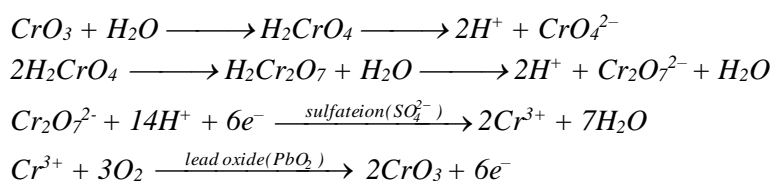

Chromium plating is a hard, attractive coating, with low coefficient of friction exhibiting wear resistance, abrasion resistance and also good corrosion resistance (with an undercoat of nickel and copper).

Applications :

- Decorative chromium provides a durable finish on cycles, automobiles, furniture, household fittings, aircraft, surgical and dental instruments.
- Hard chromium is mostly used in industries in the making of gauzes, dies, cutting tools, piston rings, cylinder liners, crankshafts of marine and aero engines, bearings, hydraulic rams and in printing industry.

Black chromium is used in optical instruments, machine tools and electronic parts. It is also used in non-glare finishes on automobiles, and as an efficient coating for solar energy collectors.

7 (a) What is cathodic protection? Explain (a) sacrificial anodic method and (b) Impressed current method. (05 Marks) (CO2, L4).

Solution: **CATHODIC PROTECTION:** Cathodic protection is a method of protecting a metal or alloy from corrosion by converting it completely into cathodic and no part of it is allowed to act as anode. This can be achieved by providing electrons from an external source.

(a) Sacrificial anodic method:

In this method, the base metal structure is converted into a cathode by connected it to a more active [higher up in galvanic series or less noble] metal. This active metal actually acts as an auxiliary anode. Mostly Zn, Mg, Al are the common auxiliary anodes used in this method. These metals being more active, acts as anode and undergo destruction and protect the metal structure.

Since the anode material sacrifice to protect the metal structure, the method is known as sacrificial anode method. After continuous use exhausted sacrificial anodes are replaced by new ones as and when required.

Ex: 1. A Mg block connected to buried oil storage tank.

2. Mg base areas fixed to the side of ocean going ships.

3. Mg blocks area connected to the buried pipe lines.

Advantages:

- (i) The method is simple.
- (ii) Low installation cost.
- (iii) Minimum maintenance cost.
- (iv) Doesn't require power supply.

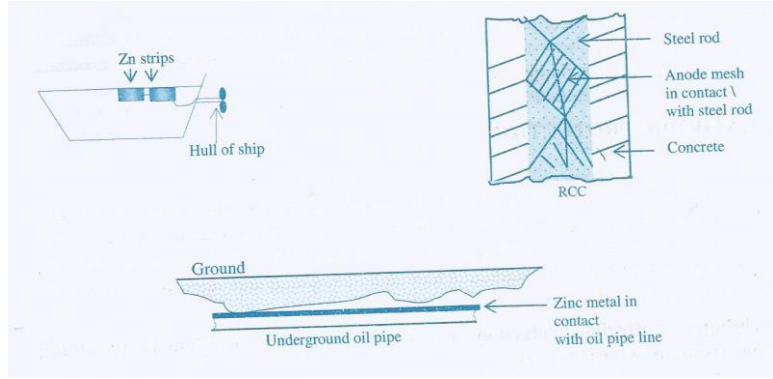

Fig: Cathodic Protection by sacrificial anode

Disadvantage:

- (i) Involves recurring expenditure for replacement of consumed anodes.

(b) Impressed current method:

In this method, by applying a direct current larger than the corrosion current, the base metal is made cathodic by connecting it to the cathode of the external source of current and the anode of the source is connected to an inert electrode (lead or graphite). The cathode is the str to be protected and anode is resin bonded graphite rod, high silicon-iron alloy or platinisedTi connected to the positive terminal.

The metal structure being cathode, doesn't undergo corrosion. Anode being inert, remains unaffected [electrons for protection are supplied by a source of direct current].

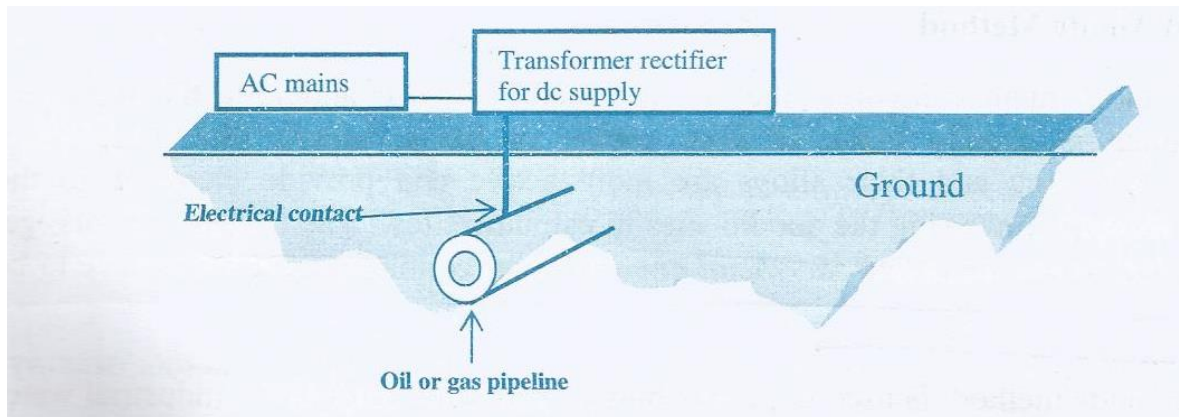

Fig: Protection using an impressed voltage

Advantages:

- (i) One installation can protect larger area of metal.
- (iii) low maintenance cost.

Disadvantages:

- (i) It is very expensive, because it needs continuous current.
- (ii) If the impressed current is not uniform on the entire surface of the protected structure, localized corrosion takes place on the protected metal.

(b) Explain the following concepts in context with electroplating. (05Marks) (CO2, L4)

(i) Polarization, and (ii) Decomposition potential or Overvoltage

Solution: 1. Polarization: A process of variation in electrode potential due to change in concentration of ionic species at electrode surface by

- (i) slow diffusion of ions from the bulk of the electrolyte to the electrode or from the electrode towards the bulk (known as concentration polarization)
- (ii) one or more of elementary steps of discharge (or evolution) of gases being slow at electrode surface (known as overvoltage polarization).

Electrode potential is a function of active mass or molar concentration of ionic species in the solution given by the Nernst equation:

$$E = E^{\circ} + \frac{2.303 RT}{nF} \log [M^{n+}]$$

For a reduction reaction at the cathodic surface, there is depletion in concentration of M^{n+} ions in the vicinity of cathodic surface. Until that time, ions diffuse from the bulk and re-establish the equilibrium, lower concentration of ionic species alters the electrode potential. Similar such phenomena can be seen at the anodic surface. This effect is known as concentration polarization. Polarization of electrodes depends upon

- (i) current densities applied
- (ii) nature of the electrode (i.e., composition, size, shape, etc.)
- (iii) nature of electrolyte, its concentration and conductivity
- (iv) agitation / temperature of the electrolyte
- (v) nature of the products formed at the electrode surfaces.

Concentration polarization can be minimized by

- (i) having larger electrode surfaces
- (ii) by optimized current densities
- (iii) lower concentrations of highly conducting electrolyte
- (iv) better agitation / higher temperature of the electrolyte

Knowledge of polarization helps one to realize the importance of agitation of electrolyte in order to minimize concentration polarization and thus, the expenses of electroplating. However, overvoltage cannot be eliminated.

2. Decomposition Potential: (or Decomposition Voltage)

Decomposition potential is the experimentally determined minimum external potential that needs to be applied in order to have continuous decomposition of the electrolyte.

For example, in the decomposition of water, a dilute solution of either an acid or alkali is electrolyzed using smooth platinum electrodes. For the applied potential less than 1.68 V, there is initial surge of current which will drop to zero in a while. When the applied potential is 1.68 V or more, there is continuous decomposition of water with the liberation of hydrogen at cathode and oxygen at the anode. Thus, 1.68 V is the decomposition potential of water.

A knowledge of discharge potentials of different electrodes helps in

- (i) Knowing the potential to be externally applied for electrolysis of any electrolyte.
- (ii) Predicting the order in which the different substances discharge or deposit at respective electrodes. For example, by the electrolysis of a solution containing Cu^{2+} ions, Zn^{2+} ions and Cd^{2+}

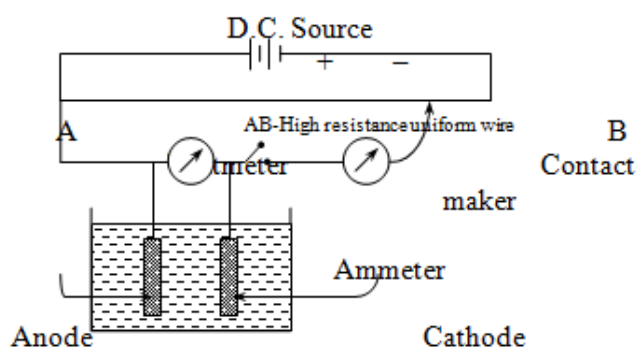

ions, Ag ions, Hg ions the discharge or deposition of metals happens to be in the order: Ag, Hg, Cu, then Cd and later, Zn.

Decomposition potential can be determined by the measurements of current for varying potentials (or voltages) applied across the electrodes immersed in electrolyte under investigation. The set up used for measurement is shown in the figure.

A plot of current against potential (or voltage) helps in knowing the decomposition potential. For lower voltages, there is no significant rise in current till the reach of decomposition potential. Beyond this potential, it starts rising abruptly. Laws of electrolysis are applicable only in this region. Decomposition potential is obtained by the intersection of the two tangents drawn as shown in the figure.

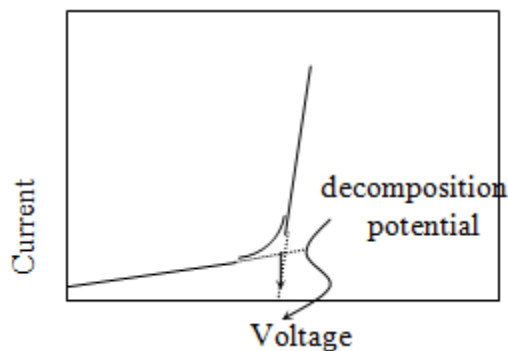

8. (a) Explain the following factors affecting rate of corrosion. (04 marks) (CO2, L4)

(i) Nature of corrosion product

(ii) pH of the medium

Solution: (i) Nature of the corrosion product

The nature of the corrosion product largely decides the rate of further corrosion. The corrosion product formed on the surface of the metal may or may not act as a protective layer.

(a) The nature of the oxide layer largely decides the rate of further corrosion. If its composition is stoichiometric, highly insoluble and non porous with low ionic and electrical conductivity, the layer acts as protective film and prevent further corrosion. For eg. Al, Ti and Cr develops such a layer on their surface and become passive to further corrosion. Stainless steel (18% Cr, 8% Ni) builds up a thin but a highly protective film of Cr_2O_3 which resist attack in a highly corrosive environment. Metals such as Zr and Mo not only form such protective layer but are also capable of self repairing the oxide films when it is damaged. Hence these metals are extremely resistant to corrosion.

(b) If the oxide layer is non stoichiometric, highly porous, soluble, unstable, it can not control further corrosion. In such cases the fresh metal surface is continuously exposed to corrosion environment and corrosion takes place continuously. Eg. Fe and Zn

(ii) pH of the medium

In general, the rate of corrosion is high when the nature of the environment is acidic.

(a) If the $\text{pH} < 3$, severe corrosion occurs even in the absence of air due to the continues evolution of hydrogen at the cathodic region.

(b) If the $\text{pH} > 10$, corrosion of the metal practically ceases, due to the formation of a protecting coating of hydrogen oxide of iron.

(b) What is electroless plating? Explain the electroless plating of nickel. (06 marks) (CO2, L4)

Solution: *Electroless-plating:* Deposition of metal or alloy over a conducting or non-conducting substrate surface by **chemical reduction of the metal ions by use of reducing reagent** and without the use of electrical energy is called electroless-plating.

Electroless-plating is generally autocatalytic in nature. Schematically, it can be represented as,

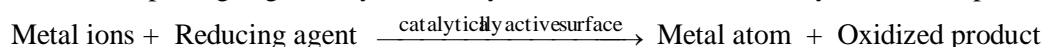

Electroless-plating of Nickel:

Electroless nickel (EN) plating is a process for depositing nickel alloy onto a substrate by electrochemical reactions.

Typically, the constituents of an EN solution are:

1. A source of nickel ions (nickel sulfate)
2. A reducing agent (Sodium hypophosphite NaH_2PO_2 , H_2O)
3. Suitable complexing agents (organic acids like lactic acid)
4. Stabilizers (Thiourea)
5. Brighteners (Thiourea)
6. Exaltants (Lactates, Succinates)

Reactions:

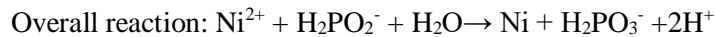
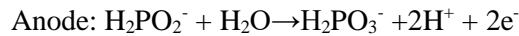
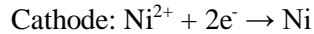

Applications:

The most common form of electroless nickel plating produces a nickel-phosphorus alloy coating. The phosphorus content in electroless nickel coatings can range from 2% to 13%. It is commonly used in engineering coating applications where wear resistance, hardness and corrosion protection are required. Applications include oilfield valves, rotors, drive shafts, paper handling equipment, fuel rails, and optical surfaces for diamond turning, door knobs, kitchen utensils, bathroom fixtures, electrical/mechanical tools and office equipment. It is also commonly used as a coating in electronics printed circuit board manufacturing, typically with an overlay of gold to prevent corrosion. This process is known as electroless nickel immersion gold.

Due to the high hardness of the coating, it can be used to salvage worn parts. Coatings of 25 to 100 micrometers can be applied and machined back to the final dimensions. Its uniform deposition profile means it can be applied to complex components not readily suited to other hard-wearing coatings like hard chromium.

It is also used extensively in the manufacture of hard disk drives, as a way of providing an atomically smooth coating to the aluminum disks, the magnetic layers are then deposited on top of this film, usually by sputtering and finishing with protective carbon and lubrication layers; these final two layers protect the underlying magnetic layer (media layer) from damage should the read / write head lose its cushion of air and contact the surface.

Its use in the automotive industry for wear resistance has increased significantly. However, it is important to recognize that only End of Life Vehicles Directive or RoHS compliant process types (free from heavy metal stabilizers) may be used for these applications.

Advantages:

1. Does not use electrical power.
2. Even coating on parts surface can be achieved.
3. No sophisticated jigs or racks are required.
4. There is flexibility in plating volume and thickness.
5. The process can plate recesses and blind holes with stable thickness.
6. Chemical replenishment can be monitored automatically.
7. Complex filtration method is not required
8. Matte, semi-bright or bright finishes can be obtained.

Disadvantages:

1. High cost of chemicals.
2. Waste treatment cost is high due to the speedy chemical renewal.
3. Porous nature of electroless plating leads to inferior material structure compared to electrolytic processes.