

# CBCS SCHEME



USN

--	--	--	--	--	--	--	--	--	--

15CV52

**Fifth Semester B.E. Degree Examination, Dec.2019/Jan.2020**

## Analysis of Indeterminate Structures

Time: 3 hrs.

Max. Marks: 80

Note: Answer any FIVE full questions, choosing ONE full question from each module.

### Module-1

- 1 Analyse the continuous beam shown in Fig Q1 by slope deflection method. Draw bending moment diagram and shear force diagram.

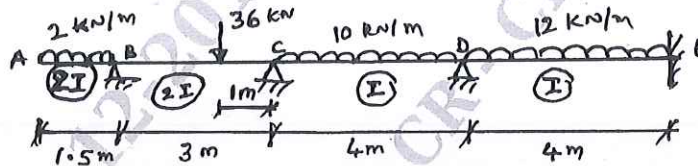

Fig Q1

(16 Marks)

OR

- 2 Analyse the portal frame shown in Fig Q2 by slope deflection method. Draw bending moment diagram.

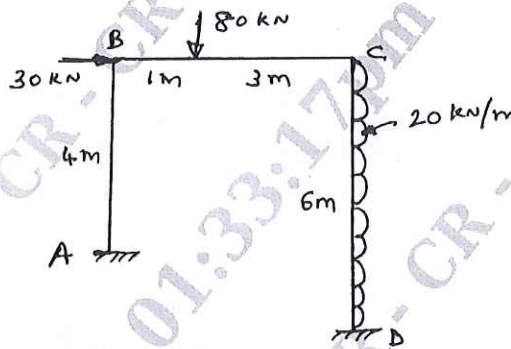

Fig Q2

(16 Marks)

### Module-2

- 3 Analyse the continuous beam shown in Fig Q3 by moment distribution method. Draw bending moment diagram and shear force diagram. Support at B sinks by 10mm.

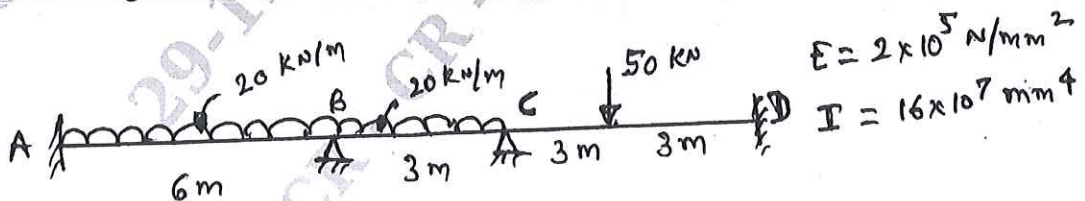

Fig Q3

(16 Marks)

Important Note : 1. On completing your answers, compulsorily draw diagonal cross lines on the remaining blank pages.  
2. Any revealing of identification, appeal to evaluator and /or equations written eg, 42+8 = 50, will be treated as malpractice.

OR

- 4 Analyse the frame shown in Fig Q4 by moment distribution method. Draw bending moment diagram.

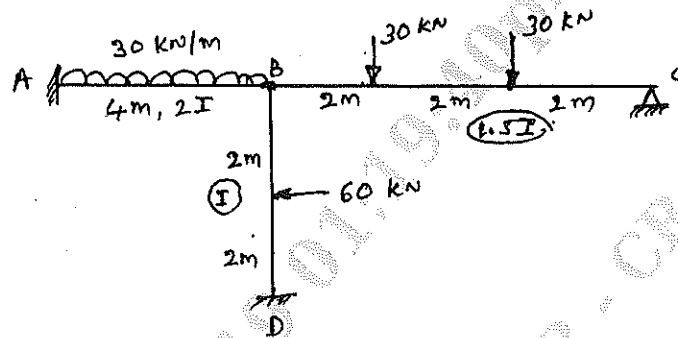

Fig Q4

(16 Marks)

**Module-3**

- 5 Analyse the continuous beam shown in Fig Q5 by rotation contribution method. Draw bending moment diagram and shear force diagram.

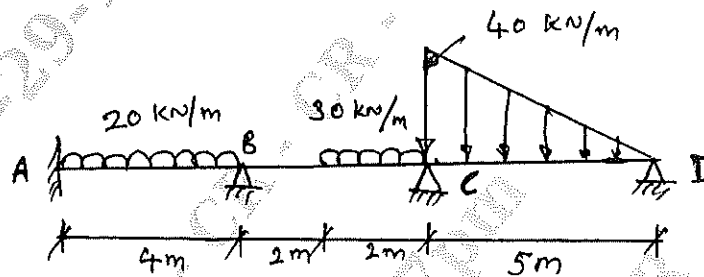

Fig Q5

(16 Marks)

OR

- 6 Analyse the frame shown in Fig Q6 by Kani's method. Draw bending moment diagram. Use axis of symmetry approach.

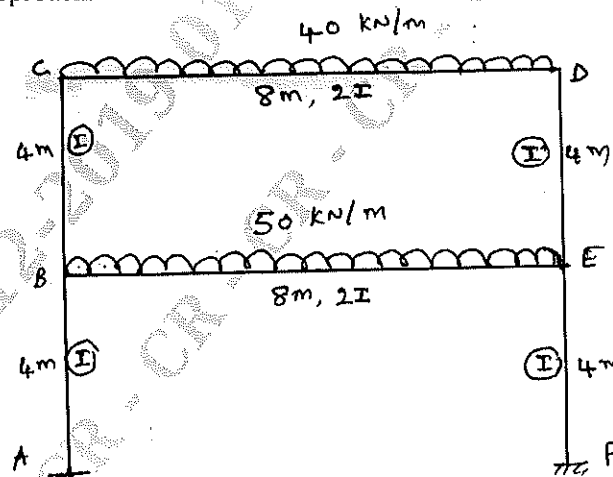

Fig Q6

(16 Marks)

**Module-4**

- 7 Analyse the continuous beam shown in Fig Q7 by flexibility matrix method. Draw BMD and SFD.

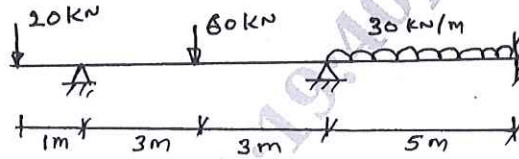

Fig Q7

(16 Marks)

OR

- 8 Analyse the pin jointed plane shown in Fig Q8 by flexibility matrix method to compute axial forces in the members. Assume  $\frac{L}{AE}$  for each member is 0.025mm/kN.

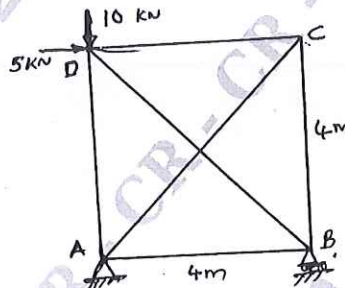

Fig Q8

(16 Marks)

**Module-5**

- 9 Analyse the continuous beam shown Fig Q9 by stiffness matrix method. Draw SFD and BMD.

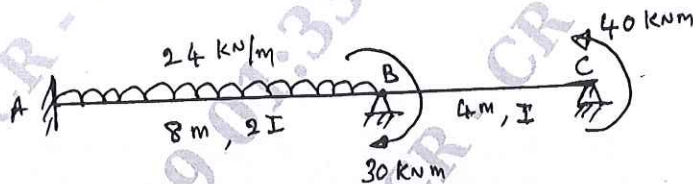

Fig Q9

(16 Marks)

OR

- 10 Analyse the portal frame shown in Fig Q10 by stiffness matrix method. Draw bending moment diagram.

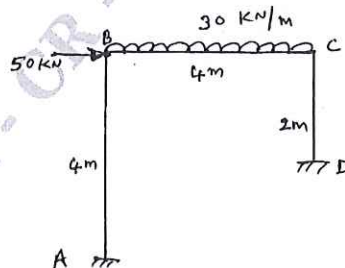

Fig Q10

(16 Marks)

\*\* 3 of 3 \*\*

