

1 (a) The steering gear mechanism is used for changing the direction of two or more of the wheel axles with reference to the chassis, so as to move the automobile in any desired path.

Condition for correct steering:

All the four wheels must turn about the same instantaneous centre (I). The axis of the inner wheel makes a larger turning angle θ than the angle ϕ subtended by the axis of outer wheel.

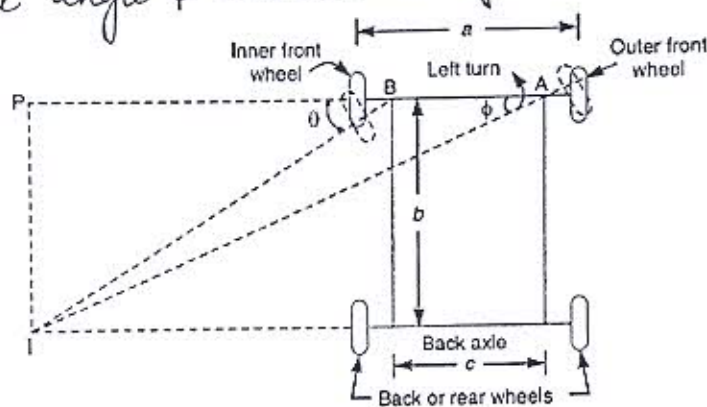

Let a = wheel track.

b = wheel base

c = Distance between the pivots A and B of the front axle.

Now from triangle, $\triangle IBP$;

$$\cot \theta = \frac{BP}{IP}$$

and from $\triangle IAP$;

$$\cot \phi = \frac{AP}{IP} = \frac{AB + BP}{IP} = \frac{AB}{IP} + \frac{BP}{IP}$$

$$\Rightarrow \cot \phi = \frac{c}{b} + \cot \theta \Rightarrow \boxed{\cot \phi - \cot \theta = c/b}$$

1 (b) Ackerman Steering Gear Mechanism : \Rightarrow

- The Ackerman Steering Gear mechanism consists of turning pairs only. Hence, the maintenance of such mechanism is reduced as there are no sliding pairs that would contribute to

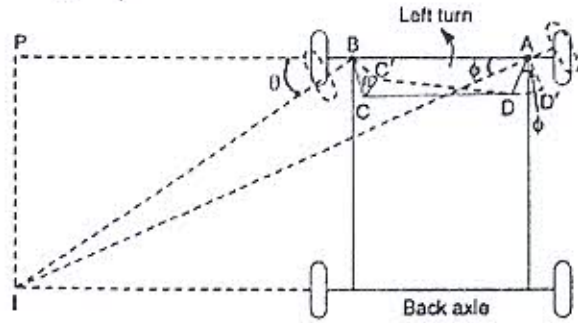

rubbing or friction.

- The whole of the mechanism is on back of the front wheels.

- In Ackerman steering gear, the mechanism ABCD is a four bar crank chain as shown in the figure.

- The shorter links BC and AD are of equal length and are connected by hinge joints with front wheel axles.

- The longer links AB and CD are of unequal length.

- The following are the only three positions for correct steering : \Rightarrow

(i) When the vehicle moves along a straight path, the longer links AB and CD are parallel and the shorter links BC and AD are equally inclined to the longitudinal axis of the vehicle, as shown by the firm lines in the above figure.

(ii) When the vehicle is steering to the left, the position

Q a.) A quick return motion mechanism is one in which the return stroke takes appreciably lesser time than the forward stroke.

- The forward stroke takes place when the crank rotates by an angle ' β ' and the return stroke takes place when the crank rotates by an angle ' α '.

- ~~Since~~ The angle ' β ' made by the forward or cutting stroke is greater than the angle ' α ' described by the return stroke.

- Since the crank rotates with uniform ~~velocity~~ angular speed, therefore the return stroke is completed within a shorter time. Thus, such a mechanism is called as a quick return motion mechanism.

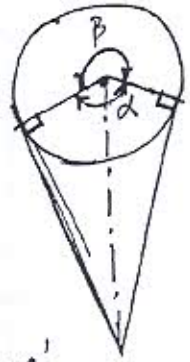

b.) Data: $\Rightarrow AC = 300 \text{ mm}$
 $CB_1 = 120 \text{ mm}$

$$\sin \angle CAB_1 = \sin(90^\circ - \alpha/2) = \frac{CB_1}{AC}$$

$$= \frac{120}{300} = 0.4$$

$$\Rightarrow \angle CAB_1 = 90 - \alpha/2$$

$$= \sin^{-1}(0.4) = 23.6^\circ$$

$$\alpha/2 = 90 - 23.6^\circ = 66.4^\circ$$

$$\Rightarrow \alpha = 2 \times 66.4^\circ \Rightarrow \boxed{\alpha = 132.8^\circ}$$

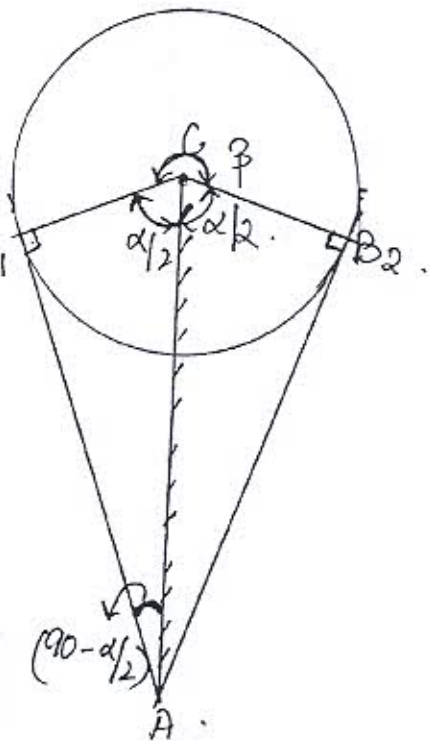

$$\text{Time Ratio (TR)} = \frac{\text{Time of cutting stroke}}{\text{Time of return stroke}} = \frac{360^\circ - \alpha}{\alpha} = \frac{360^\circ - 132.8^\circ}{132.8^\circ}$$

$$\Rightarrow \boxed{\text{Time Ratio} = 1.72} \quad (\text{Ans})$$

(6)
 of the gear is shown by dotted lines in the figure.
 In this position, the lines of the front wheel axle intersect on the back wheel axle at I for correct steering.

(iii) When the vehicle is steering to the right, the similar position may be obtained.

3(a). The mechanisms used for permitting only relative motion of an oscillatory nature along a straight line is called a straight line motion mechanism.

Condition for straight line mechanism: \Rightarrow

$$AQ \times OP = \text{Constant}$$

(b). The ~~link~~ mechanism consists of 8 links.

Geometric relation: \Rightarrow

$$OA = OQ$$

$$AB = AC$$

$$BP = PC = CQ = QB \quad (\text{sides of rhombus})$$

Trace Point is P.

(c) OA is the fixed link and OQ is a rotating link or crank.

To prove: \rightarrow As the link OQ moves around O; P moves in a straight line $I'I$ to OA. All the joints are pin-jointed.

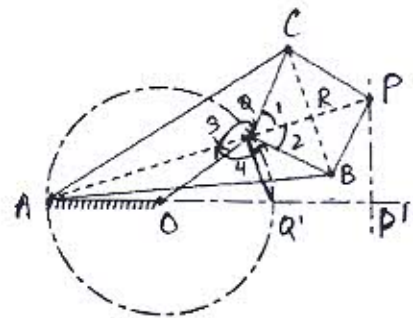

$\triangle PCQ$ is a rhombus,

QP always bisects $\angle BQC$;

$$\Rightarrow \angle 1 = \angle 2 \quad \text{--- (1) in all positions.}$$

In $\triangle AQC$ and $\triangle AQB$;

AQ is common;

$$AC = AB.$$

$$QC = QB.$$

Hence $\triangle AQC \cong \triangle AQB$; in all positions.

$$\Rightarrow \angle 3 = \angle 4 \quad \text{--- (2)}$$

Adding Eqⁿ (1) & (2);

$$\angle 1 + \angle 3 = \angle 2 + \angle 4.$$

$$\text{But } \angle 1 + \angle 2 + \angle 3 + \angle 4 = 360^\circ.$$

$$\Rightarrow \angle 1 + \angle 3 = \angle 2 + \angle 4 = 180^\circ \Rightarrow A, Q \text{ \& } P \text{ line}$$

Let PP' be the \perp^o on AO produced. Len a straight line.

From $\triangle AQQ'$ & $\triangle APP'$

$\angle S$ is common; $\angle AQQ' = \angle APP' = 90^\circ$.

$$\Rightarrow \triangle AQQ' \sim \triangle APP'.$$

$$\therefore \frac{AQ}{AP'} = \frac{AQ'}{AP}$$

$$\Rightarrow AQ' \times AP' = AQ \times AP = (AR - RQ)(AR + RP) \\ = (AR - RQ)(AR + RQ).$$

$$\Rightarrow AQ' \times AP' = AR^2 - RQ^2 \\ = (AC^2 - CR^2) - (CQ^2 - CR^2).$$

$$\Rightarrow \boxed{AP' = \frac{AC^2 - CQ^2}{AQ'}} = \text{Constant as } AC, CQ \text{ and } AQ' \text{ are always fixed.}$$

This means that the projection of P and AO produced is constant for all the configurations.

Thus, PP' is always a normal to AO produced as P moves

4(a). Elliptical trammel is an inversion of

Double slider crank mechanism.

- This inversion is obtained by fixing the slotted plate (link 4).

- The fixed plate has two straight grooves cut in it, at right angles to each other.

- The link 1 and link 3 are known as sliders and form sliding pairs with link 4.

- The link AB (link 2) is a bar which forms turning pair with links 1 and 3.

- It is an instrument used for drawing ellipses.

- When the links 1 and 3 slide along their respective grooves, any point on the link 2 such as P traces out an ellipse on the surface of link 4.

- AP and BP are the semi-major axis and semi-minor axis of the ellipse respectively.

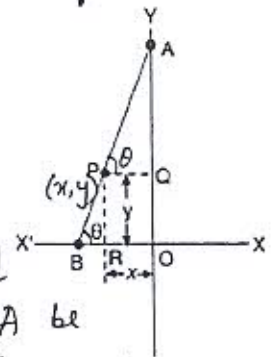
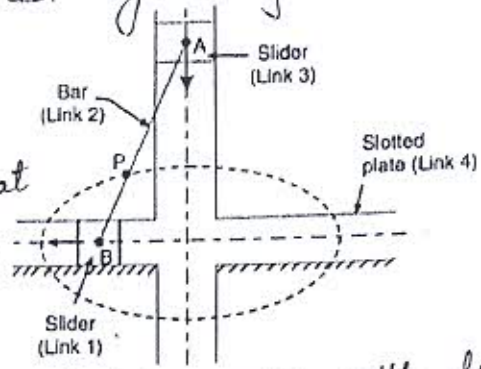

(b). Let us take OX and OY as horizontal and vertical axes and let the link BA be inclined at an angle θ with the horizontal. P has the co-ordinates as (x, y) .

$$\text{From } \triangle PAQ; \cos \theta = \frac{x}{AP} \quad \text{--- (1)}$$

$$\triangle PBR; \sin \theta = \frac{y}{BP} \quad \text{--- (2)}$$

Squaring and adding Eqⁿ (1) + (2);

$$\frac{x^2}{AP^2} + \frac{y^2}{BP^2} = \sin^2 \theta + \cos^2 \theta = 1.$$

This is the equation of an ellipse. Hence the path traced by point P is an ellipse. Its semi-major axis is AP and

5 (i) Ratchet and Pawl Mechanism : \Rightarrow

- A ratchet is a device that allows linear or rotary motion in only one direction.

- The figure besides is a ratchet and pawl mechanism.

- Ratchet consists of a gear wheel and a pivoting spring loaded pawl that engages the teeth.

- The teeth or the pawl, are at an angle so that when the teeth are moving in one direction, the pawl slides in between the teeth.

- The spring forces the pawl back into the depression between the next teeth.

- The ratchet and pawl are not mechanically interlocked hence easy to set-up. But the reverse motion of the ratchet is stopped by the locking pawl.

- It is an example of an intermittent motion mechanism.

- It finds its application in currency counting machines, indexing, etc.

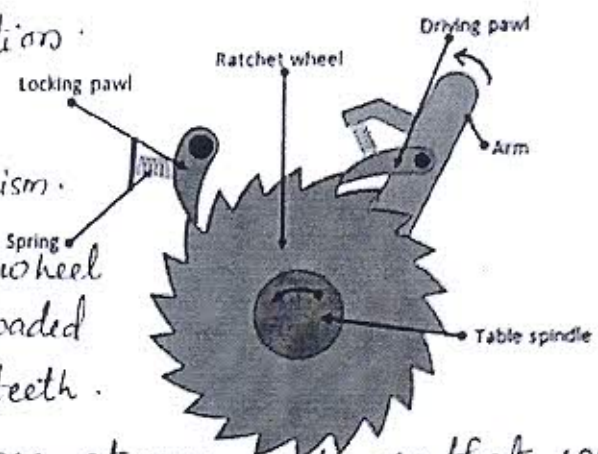

(ii) Geneva Wheel Mechanism : \Rightarrow

- The Geneva wheel mechanism translates a continuous rotation into an intermittent rotary motion.

- The rotating drive wheel has a pin that reaches into the slot of the Geneva wheel.

- The drive wheel also has a raised circular blocking disc that locks the drive wheel in position between

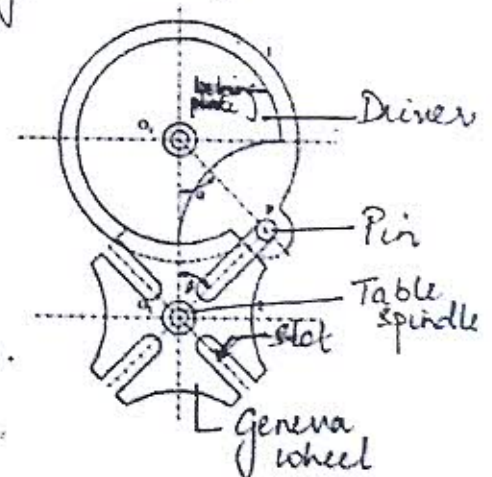

steps as shown in the above. (11)

- In the simplest form, the driver wheel has four slots and hence for each rotation of the driver wheel, it advances by one step of 90° .
- If the driver wheel has 'n' slots, it advances by $360/n$ per full rotation of the driver wheel.

(iii) Gnome Engine \Rightarrow

- Gnome engine is rotary internal combustion engine.
- Previously Gnome engines were used in aviation.

But now-a-days gas turbines are used in its place because of its high weight to power ratio and vibrations associated.

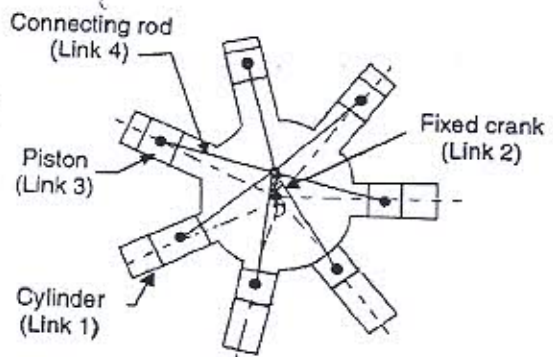

- It consists of seven cylinders in one plane and all revolves about a fixed centre 'D', as shown in the figure.
- In this mechanism, as the connecting rod (Link 4) rotates, the piston (Link 3) reciprocates inside the cylinders forming link 1 thereby producing power continuously.

6 (i) Higher Pair

1. When a pair has a point or line contact between the links, it is known as higher pair.
2. Contact surfaces are dissimilar.

Eg: - A cam with a knife edge follower.

Lower Pair

1. A pair of links having surface contact or area contact between the members / links are called as lower pair.
2. Contact surfaces are similar.

Eg: - A shaft rotating inside a bearing.

(ii) Machine

1. Relative motion exists between its parts.
2. Links are meant to transmit motion and power.
3. It is meant for transmitting useful energy to do certain type of work.

Eg: - Lathe

Structure

1. No relative motion exists between its members.
2. The members of a structure transmit only forces or straining loads.
3. No useful energy is transmitted by it.

Eg: - Roof truss.

(iii) Constrained Motion.

1. When the motion between two elements of a pair is in a definite direction irrespective of the direction of force applied, it is known as a completely constrained motion.

Eg:- Sliding or turning pair.

(iv) Degree of Freedom.

1. Degree of freedom of a pair is defined as the number of independent motions both rotational and translational that a pair can have.



Un-constrained Motion.

1. When the motion between the two elements of a pair is possible in more than one direction and depends upon the force applied, it is known as unconstrained motion.

Eg:- A circular shaft in a circular hole.

Mobility.

1. Mobility is defined as the number of degrees of freedom that a mechanism can have.