

USN

--	--	--	--	--	--	--	--	--	--	--	--	--	--	--	--	--	--	--	--



Internal Assessment Test 2 – April 2019

Sub:	Automobile Engineering					Sub Code:	15ME655	Branch:	ME
Date:	16/04/19	Duration:	90 min's	Max Marks:	50	Sem / Sec:	VI/A&B		OBE
<u>Answer any FIVE FULL Questions</u>									MARKS
1.	Explain zenith carburetor with a neat sketch.						[10]	CO4	L2
2.	Compare Supercharging and Turbo charging. Define intercooler and turbo charger lag.						[10]	CO4	L2
3.	Explain methods of supercharging and also discuss limitations of supercharging.						[10]	CO4	L2
4.	Explain octane number and cetane number and also explain normal and abnormal combustion in SI engines.						[10]	CO4	L2
5.	Explain mechanical and electronic fuel injection systems with neat sketches.						[10]	CO4	L2
6.	Explain the working of fuel injector with a neat sketch.						[10]	CO4	L2
7.	Explain any two superchargers with a neat sketch.						[10]	CO4	L2

USN

--	--	--	--	--	--	--	--	--	--	--	--	--	--	--	--	--	--	--	--



Internal Assessment Test 2 – April 2019

Sub:	Automobile Engineering					Sub Code:	15ME655	Branch:	ME
Date:	16/04/19	Duration:	90 min's	Max Marks:	50	Sem / Sec:	VI/A&B		OBE
<u>Answer any FIVE FULL Questions</u>									MARKS
1.	Explain zenith carburetor with a neat sketch.						[10]	CO4	L2
2.	Compare Supercharging and Turbo charging. Define intercooler and turbo charger lag.						[10]	CO4	L2
3.	Explain methods of supercharging and also discuss limitations of supercharging.						[10]	CO4	L2
4.	Explain octane number and cetane number and also explain normal and abnormal combustion in SI engines.						[10]	CO4	L2
5.	Explain mechanical and electronic fuel injection systems with neat sketches.						[10]	CO4	L2
6.	Explain the working of fuel injector with a neat sketch.						[10]	CO4	L2
7.	Explain any two superchargers with a neat sketch.						[10]	CO4	L2

Scheme Of Evaluation
Internal Assessment Test 1 – March 2019

Sub:	Automobile Engineering					Code:	15ME655		
Date:	06/03/2019	Duration:	90mins	Max Marks:	50	Sem:	VI	Branch:	ME

Note: Answer Any Five Questions

Question #	a)	Description	Marks Distribution		Max Marks
1	a)	Explain zenith carburetor with a neat sketch <ul style="list-style-type: none"> • Diagram • Explanation 	5 M 5 M	10 M	10 M
2	a)	Compare Supercharging and Turbo charging. Define intercooler and turbo charger lag. <ul style="list-style-type: none"> • Comparison • Intercooler • Turbo charger lag 	6 M 2 M 2M	10 M	10 M
3	a)	Explain methods of supercharging and also discuss limitations of supercharging. <ul style="list-style-type: none"> • Diagram • Explanation 	6 M 4 M	10 M	10 M
4	a)	Explain octane number and cetane number and also explain normal and abnormal combustion in SI engines. <ul style="list-style-type: none"> • octane number and cetane number • normal and abnormal combustion 	5 M 5 M	10 M	10 M
5	a)	Explain mechanical and electronic fuel injection systems with neat sketches <ul style="list-style-type: none"> • Diagram • Explanation 	5 M 5 M	10 M	10 M
6	a)	Explain the working of fuel injector with a neat sketch.. <ul style="list-style-type: none"> • Diagram • Explanation 	5 M 5 M	10 M	10 M
7	a)	Explain any two superchargers with a neat sketch. <ul style="list-style-type: none"> • Diagram • Explanation 	5 M 5 M	10 M	10 M

1. In this, float chamber is supplied with fuel from the fuel tank through a pipe. Whenever the float chamber falls short of fuel, the fuel from the fuel tank flows into the chamber at the fastest speed. The speed of fuel will match the requirement of an engine. Hence the float rises up, till it reaches a certain level. At this time, a needle valve moves down and rest against the seat. So, it resulting the stoppage of fuel supply from the fuel tank. The main jet is directly connected to the float chamber. While the auxiliary jet which is also called as compensating jet draws fuel from an auxiliary chamber (Reservoir). This auxiliary chamber is connected to the float chamber through an orifice. Both, main and auxiliary jet is opened up in the venturi. The air to the carburetor is supplied through the passage. The throttle valve is located at the end of the carburetor and connected to the engine suction pipe. The opening and the closing of the throttle valve controls the quantity of air-fuel mixture supplied to the engine suction manifold. An auxiliary nozzle from an auxiliary chamber (Reservoir) is located at one end of the by-pass. The other end of this nozzle opens up near the throttle valve.

Working of Zenith Carburetor at Starting and Low-Speed Running

Because of lower velocity of air at the time of starting or slow speed of the engine, the suction produced at the venturi is quite insufficient to operate the main and the auxiliary jet in a nozzle. To improve the velocity of air, the throttle valve is closed to such an extent that there is only a small contracted passage is provided near the end of by-pass. By this, the velocity of air, passing through the region increases, producing the high suction. This operates the nozzle at the auxiliary chamber and the air-fuel mixture supplied through the holes. There is starting and slow running device is fitted in the reservoir (Auxiliary Chamber). To vary the supply of air to the nozzle, the set screw given is slackened and the whole assembly is taken out. By the suitable number of rotation of screw joint, the position of an auxiliary nozzle is set. The whole device is then again fitted to the carburetor and tightened the screw.

Working of Zenith Carburetor at Normal Running

At this condition, the throttle valve is opened about 66% and as the air entering through the passage. It passes through the venturi, its velocity increases due to smaller area consequently its pressure drops. Hence resulting in the suction effect. The fuel is sprayed in the venturi by a main and auxiliary nozzle. As the speed of the engine increases, thereby producing the greater suction. Due to this, greater fuel being supplied by the main nozzle.

Since the compensating jet (Auxiliary Jet) draws fuel from a reservoir (Auxiliary Chamber), which is subjected to atmospheric pressure, through the air, the quantity of fuel supplied by it to the venturi does not change to an appreciable extent. This has the effect of supplying a weaker solution than if only one jet were a provider in which case, the air-fuel mixture supplied at high speed will be richer than desired. Thus the compensating jet enables the air-fuel mixture of the desired strength to be supplied. In fact, with the correctly proportioned design of various parts of this carburettor, the fuel supplied by the main and compensating nozzle can be made to bear almost a constant ratio to the air supplied.

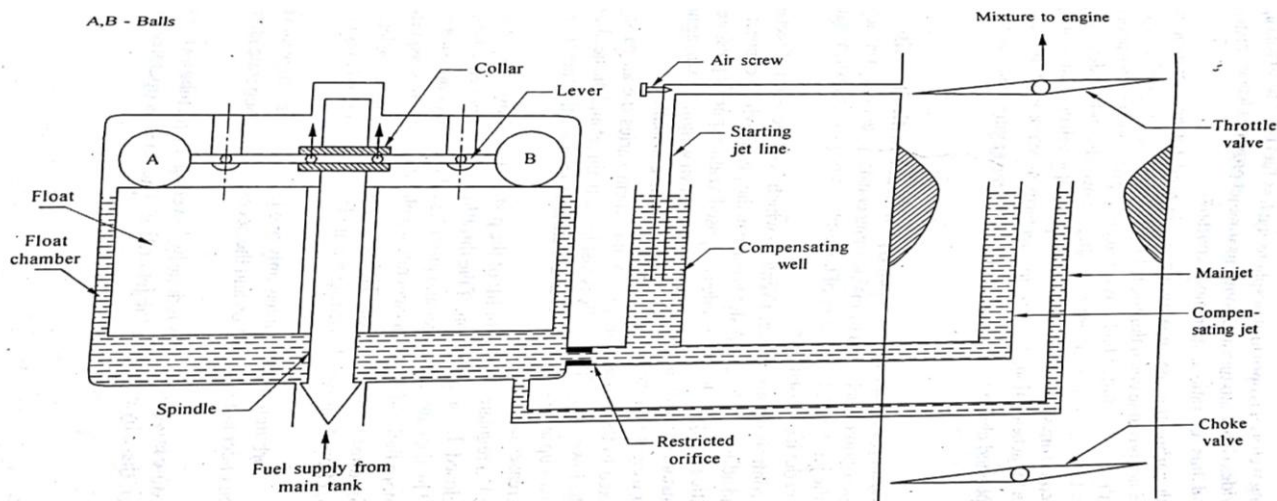

Turbo charging

- 1) The energy of exhaust gases is used to run Superchargers
- 2) It needs a waste gate control
- 3) It requires special exhaust manifolds
- 4) In CI engine it reduces smoke
- 5) Blade erosion takes place
- 6) Fuel injection modification is needed
- 7) Pressure ratio is high
- 8) It is bulky & heavy
- 9) Early scavenging
- 10) Poor response to load change

Super charging

- 1) The mechanical energy of prime mover is used to run super charges.
- 2) Not required
- 3) It does not required
- 4) In CI engine it reduces knock tendency
- 5) No blade erosion problem
- 6) Fuel injection modification is not required.
- 7) Comparatively pressure ratio is low.
- 8) It is light & compact.
- 9) Scavenging is difficult
- 10) Better response to load change.

Inter cooling (After cooler) (charge cooling)

Since the air is pressurized in the compressor it increases its pressure & return temperature of the air. This has an effect of the operating temperature of the engine. Therefore an inter cooler is required to control the temperature of inlet air.

Turbo charger lag

It is the time period required for the exhaust gases to accelerate the turbine & compressor. It represents short delay period before the boost pressure increases.

3 Methods of Super charging

In the first arrangement, the engine drives a compressor which is coupled to it by using step up gearing. A part of the power developed by the engine is used to run compressor & compressor super charges the engine.

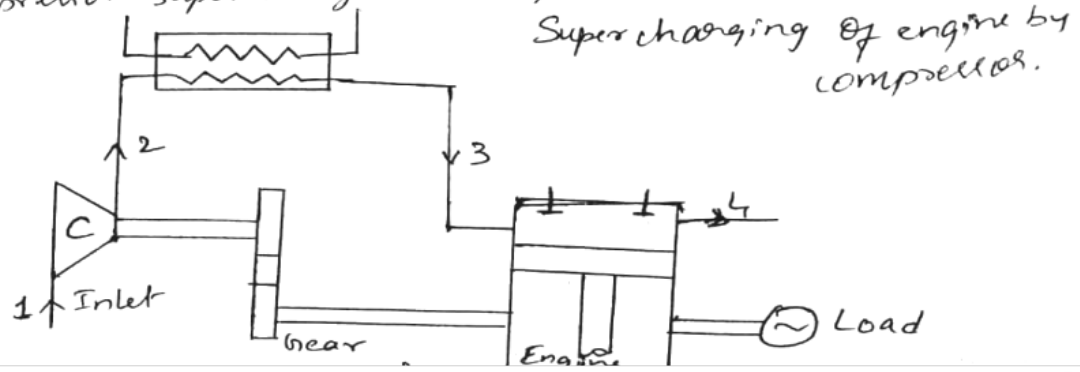

2) Second arrangement :- In this the turbine is coupled to the compressor which is driven by the engine exhaust gases. The turbine used is free from engine. The power output of the engine is not used to run compressor. This called Turbocharging.

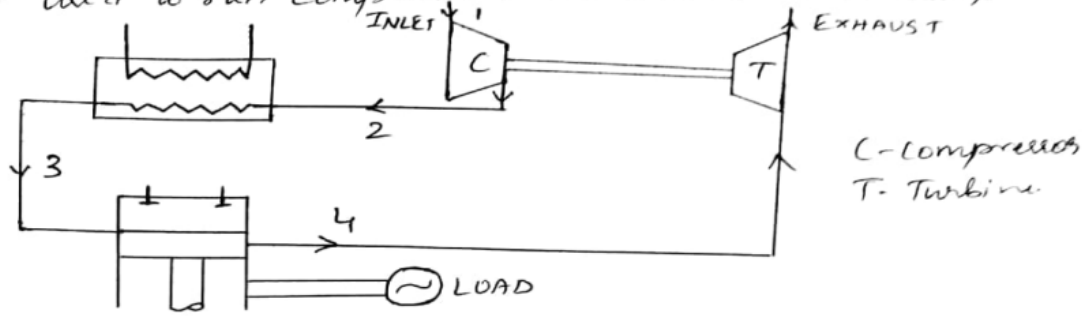

Supercharging with turbine driven by engine exhaust

3) Third arrangement :- In this all the components i.e., engine, turbine & compressor are coupled together with gearing. In this case engine supplies additional power to compensate this loss power of the turbine & vice versa.

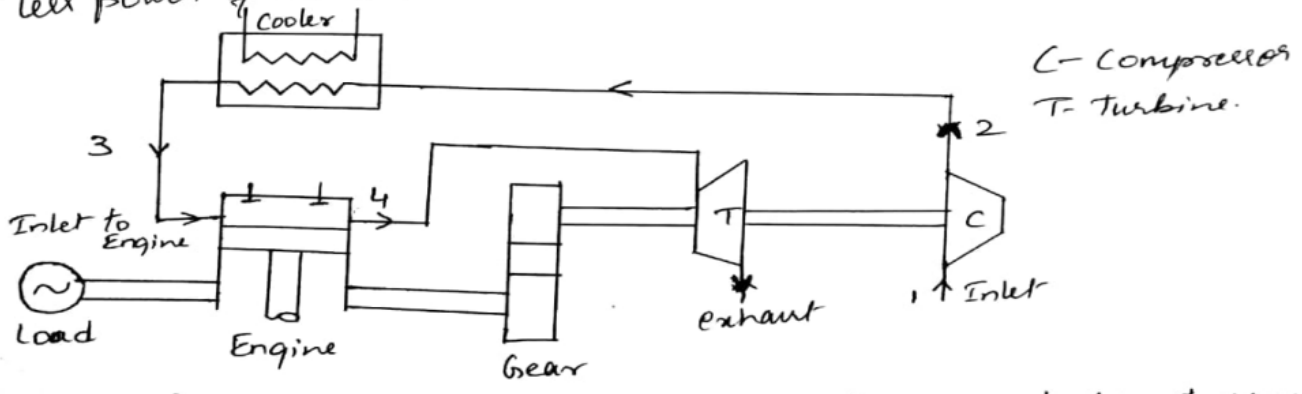

Supercharging arrangement in which engine, turbine & compressor are all coupled

4) In fourth arrangement :- The total power of the engine is used to run the compressor & exhaust gases from engine drives a turbine to give power output. This type of arrangement is also called as free piston engine.

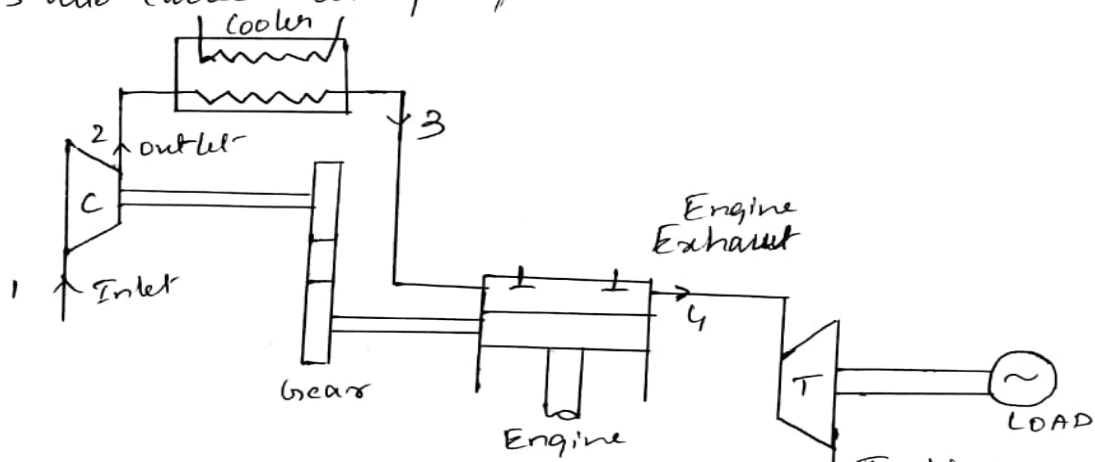

Super charging method in which engine runs compressor & turbine develops power.

Super charging limits

The factors limiting supercharging are engine knocks, thermal & mechanical loads limits the power output of the engine.

In SI engines the limit of supercharging is mainly limited by knock. The range of super charger pressure is 1.3 to 1.5 bar above that it increases the tendency to detonate.

In C.I engines the degree of supercharging is limited by thermal & mechanical load. which is the most important factor of consideration in the design of engine.

4) Octane number is a measure of detonation tendency of the petrol fuel. Petrol fuel is usually a combination of Iso octane & n-heptane. Iso octane has great resistance to detonations & is assigned with a rating of 100 & n-heptane has least resistance to the detonation & is assigned with a rating of zero.

The percentage of iso octane by volume in a mixture of iso octane & n-heptane which exactly matches the knocking intensity of a given fuel in a standard engine & prescribed operating conditions is termed as octane numbers.

Cetane number is a measure of ignition lag in diesel engines. Cetane is a straight chain paraffin assigned with a rating of 100 cetane number & has good ignition quality. It is mixed with alpha-methyl naphthalene a hydrocarbon with poor ignition quality.

Thus the cetane number of the fuel is defined as the percent by volume of cetane in a mixture of cetane & alpha-methyl naphthalene that produces same ignition lag as the fuel being tested in same engine & same operating conditions.

So as the ~~iso~~ octane number increases knocking tendency decreases & as the cetane number increases the knocking tendency increases.

Mechanical injection

5

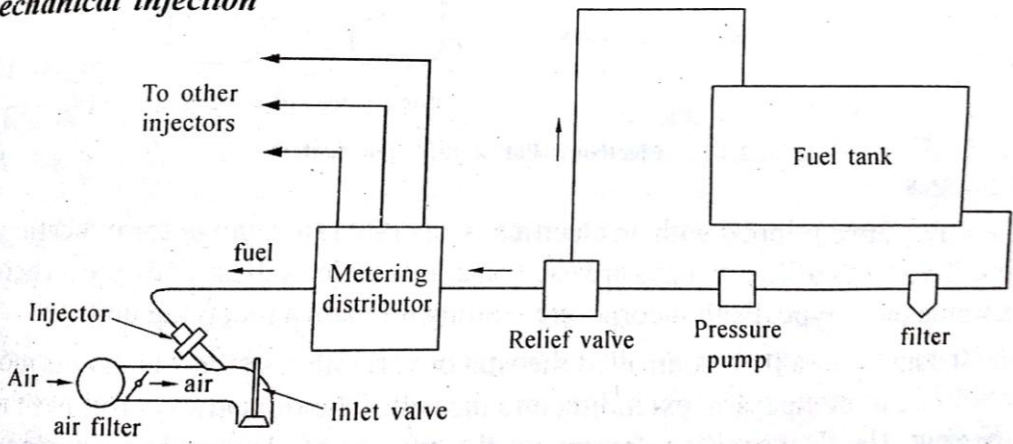

A high-pressure electric fuel pump mounted near the fuel tank pumps fuel at a pressure of 100psi up to a fuel accumulator. This is basically a short-term reservoir that keeps the fuel-supply pressure constant and also irons out the pulses of fuel coming up from the pump. From the accumulator, the fuel passes through a paper element filter and then feeds into the fuel-metering control unit, also known as the fuel distributor. This unit is driven from the camshaft and its job, as the name suggests, is to distribute the fuel to each cylinder, at the correct time and in the correct amounts.

The amount of fuel injected is controlled by a flap valve located in the engine's air intake. The flap sits beneath the control unit and rises and falls in response to airflow - as you open the throttle, the 'suck' from the cylinders increases the airflow and the flap rises. This alters the position of a shuttle valve within the metering control unit to allow more fuel to be squirted into the cylinders.

From the metering unit, the fuel is delivered to each of the injectors in turn. The fuel then squirts out into the inlet port in the cylinder head. Each injector contains a spring-loaded valve that is kept closed by its spring pressure. The valve only opens when the fuel is squirted in.

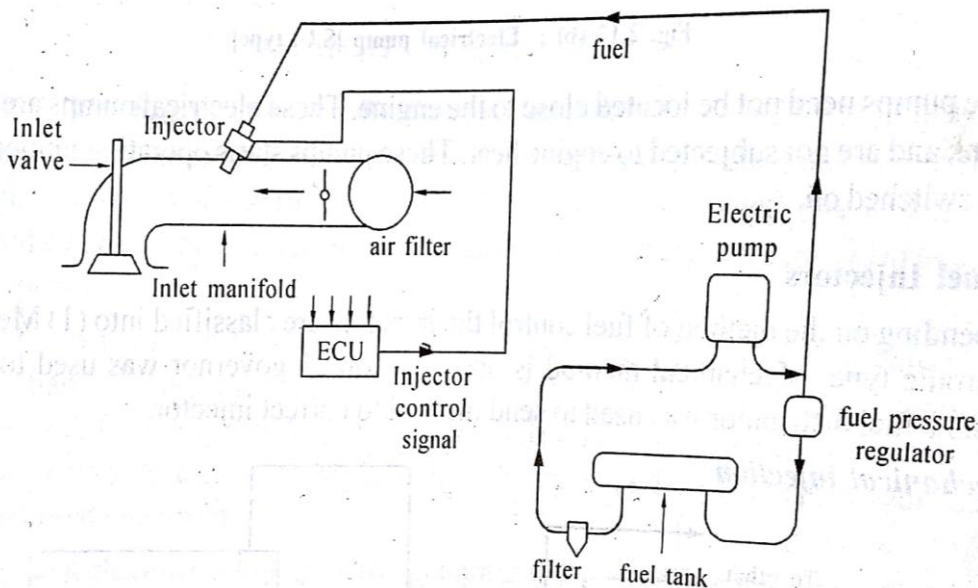

The main difference between electronic injection and mechanical injection is that an electronic system is controlled by a complex microprocessor control unit (sometimes called an electronic control unit or ECU), which is basically a miniature computer. This computer is fed with information from sensors mounted on the engine. These measure factors such as the air pressure and temperature in the air intake, the engine temperature, accelerator position and engine speed. All this information allows an electronic system to meter the fuel far more accurately than the simple mechanical system, which relies on sensing the airflow alone. The computer compares the input signals from the sensors with information already programmed into it at the factory, and works out exactly how much fuel should be delivered to the engine. It then signals the on-off valve in the injector to open and squirt fuel into the inlet port. All this happens in a fraction of a second, the control unit responding instantly to changes in accelerator position, temperature and air pressure.

As well as improved control over fuel flow, the electronic system also operates at lower pressure than a mechanical system - usually at around 25-30psi. This makes it run more quietly than a mechanical system does.

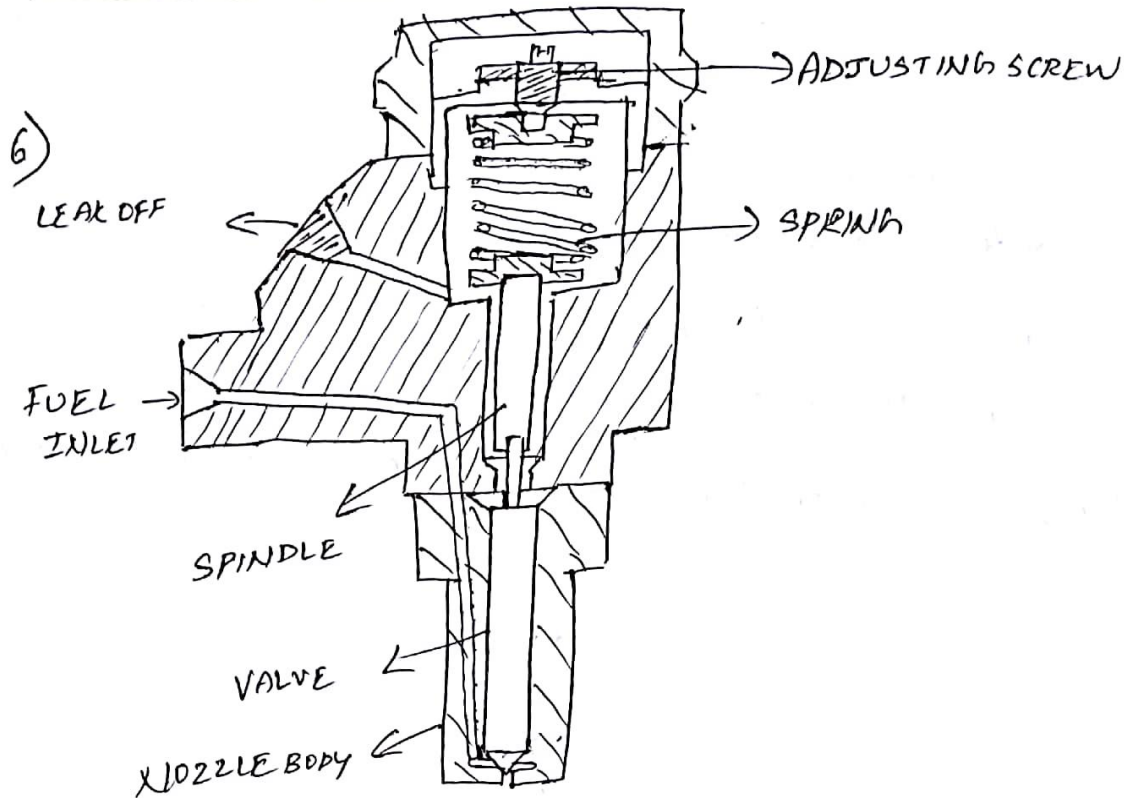

FUEL INJECTOR

A spring loaded injector is as shown in fig

- The fuel pump supplies fuel to the injector
- The high pressure fuel lifts the spring loaded valve
- The fuel is then injected into the combustion chamber
- As the pressure decreases the valve automatically closed by the spring force
- The duration of open period of the valve controls the amount of fuel injected into the combustion chamber
- The spindle connected to the springs through end caps helps in maintaining the pressure & also helps in closing the valve in the nozzle body.

7 Types of Superchargers

1) Centrifugal type superchargers

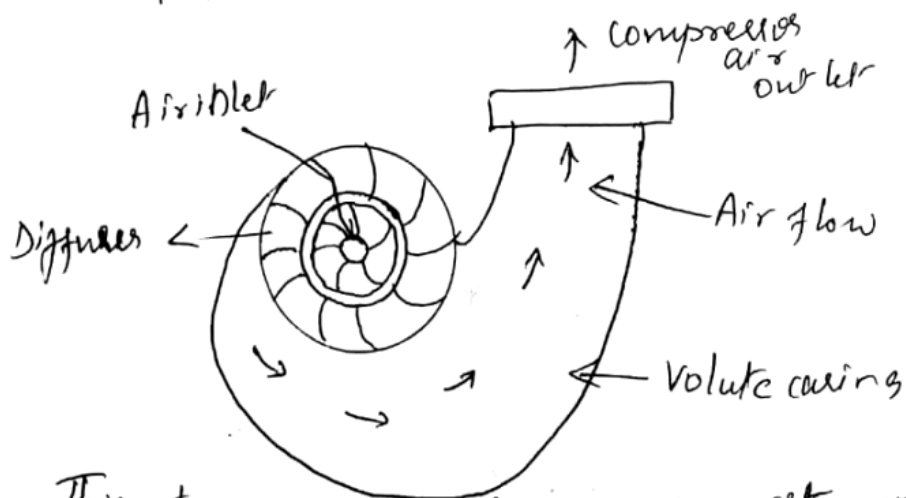

This type of supercharger is most commonly used in Automotive engines. It consists of an impeller made of alloy steel & rotates at high speeds (about 80,000rpm) inside a closely fitted casing.

- ① The air enters axially at the centre of impeller & radial vanes deflect air flow by 90° .
- ② Due to the centrifugal action high air at high velocity passes through the diffusers & volute casing getting compressed increasing air pressure.
- ③ Then this high pressure air is supplied to the engine.
- ④ Here the supercharger is driven by engine through V-belt.
- ⑤ Due to entry of compressed air, 30% more air can be forced into combustion chamber.

Roots blower (Root's super charger)

This is similar to a gear pump & consists of two epicycloid shaped rotors. Each of them keyed to its shaft & housed in a common housing.

These rotors are connected together by means of equally sized gears & hence rotate at same speeds.

At inlet air enters into the space between the rotors & elliptical housing & compressed.

A sudden pressure rise occurs when discharge port is open & at outlet air pressure is higher than inlet pressure.

These super chargers do not require lubrication & are suitable for pressure ratios upto 1.1 to 2.0.

