

DEPARTMENT ELECTRONICS & COMMUNICATION ENGINEERING

Solution of IAT-1

Computer Communication Networks(15EC64)

Q 1) Five Components of a data communication system

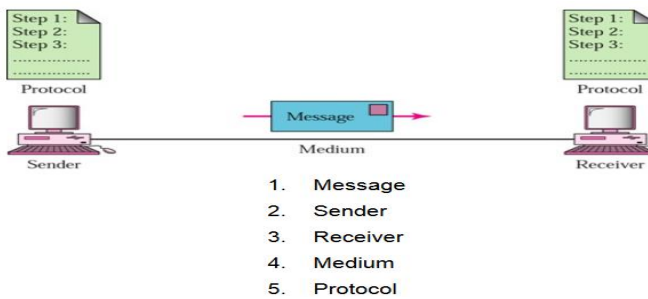

Network Topologies: It describes the geometric arrangement of components that make up the LAN

Topologies: Bus, Star, Ring, Mesh

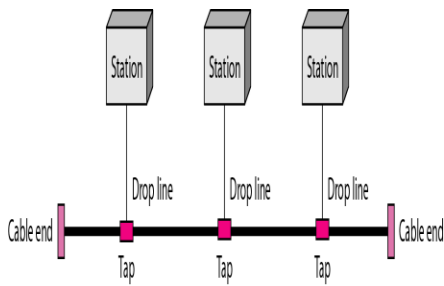

Bus Topology

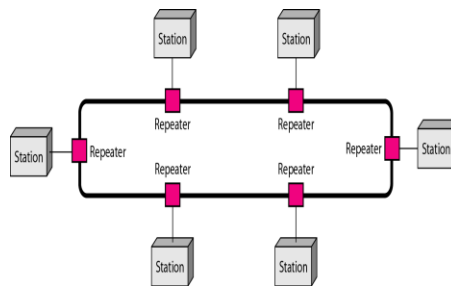

Ring Topology

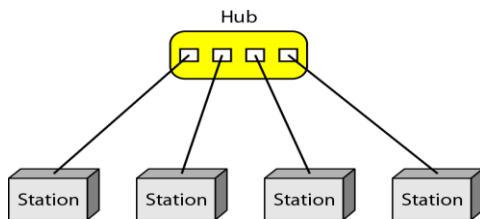

Star Topology

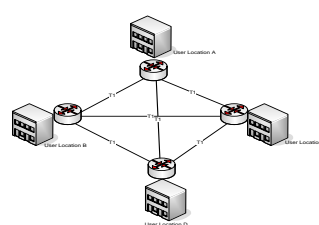

Mesh Topology

Q 2 Protocol Layers with principles.

A protocol is required when two entities need to communicate. When communication is not simple, we may divide the complex task of communication into several layers where each task performs some specific function.

Scenerio-1 (Only one protocol is used for communication- means one common language)



Scenerio-3 (When Maria has moved to some remote place and still want to be in contact with Ann)

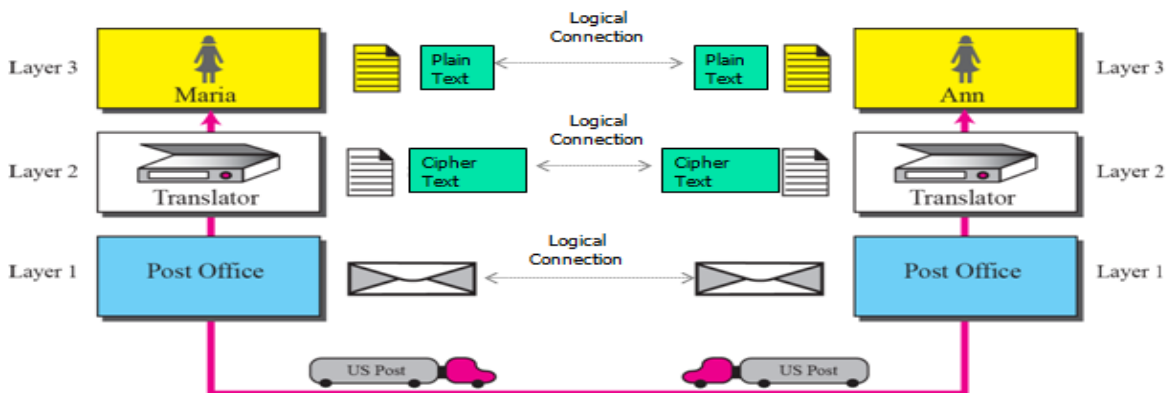

Different Protocols are used at different layers to perform different task.

TCP/IP PROTOCOL SUITE

- 1) The TCP/IP protocol suite was developed DOD of USA in early 1970's.
- 2) Protocol suite means a set of protocols organized in different layers performing some different task.
- 3) It is hierarchical protocol suite.
- 4) TCP/IP is a five-layer model



Application Layer [PDU: Message]

- Provide a virtual terminal to the users.
- Deals with File transfer, access, management and remote login

Transport Layer [PDU: Segment]

- Deals with the process to process delivery of the data.
- This layer guarantees the data transmission.
- Two protocols are used.
TCP (Transmission Control Protocol, connection oriented)
UDP (User Datagram Protocol, connection less)
- Deals with Reliable end-to-end delivery of a message

Network Layer [PDU: Packet]

- Responsible for assigning logical address i.e. IP address.
- IP address is a 32 bit address like 172.16.25.41.
- Two main protocols works at this layer are IPV4, IPV6, ICMP, IGMP
- Deals with the host to host delivery of data i.e. end to end delivery of packet.
- Deals with formation of packets.
- Routers works at the Network layer which establishes the best delivery path (*routing*)

Data Link Layer [PDU: Frame]

- Responsible for assigning physical address.
- Mac address is 48 bit address.
- Deals with the framing, error control, flow control, hop to hop delivery.

Physical Layer

- Convert frame to bits.
- Cables, hubs, connectors works at physical layers.
- Deals with formation of frame.

Q 3 Comparison between OSI and TCP/IP

OSI(Open System Interconnection)	TCP/IP(Transmission Control Protocol / Internet Protocol)
1. OSI is a generic, protocol independent standard, acting as a communication gateway between the network and end user.	1. TCP/IP model is based on standard protocols around which the Internet has developed. It is a communication protocol, which allows connection of hosts over a network.
2. In OSI model the transport layer guarantees the delivery of packets.	2. In TCP/IP model the transport layer does not guarantees delivery of packets. Still the TCP/IP model is more reliable.
3. Follows vertical approach.	3. Follows horizontal approach.
4. OSI model has a separate Presentation layer and Session layer.	4. TCP/IP does not have a separate Presentation layer or Session layer.

Addressing schemes:

Application layer: Specific Address are used

Transport Layer: Port Address are used

Network Layer: Logical Address are used

Data link layer: Physical address are used.

Q 4) Explain ARP with response and reply packet

ARP is an network layer protocol which accepts a logical address from the IP protocol, maps the address to the corresponding physical address and pass it to the data link layer. The mapping of IP address to physical address is done by using ARP (Address Resolution Protocol).

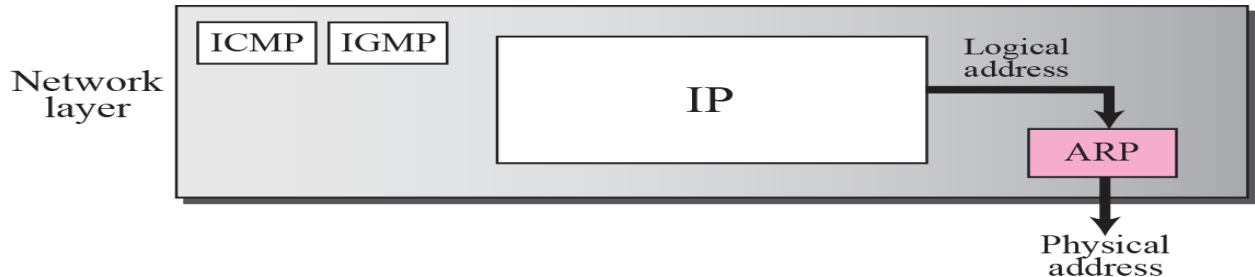

ARP packet

0	8	16	31
Hardware Type		Protocol Type	
Hardware length	Protocol length	Operation Request:1, Reply:2	
Source hardware address			
Source protocol address			
Destination hardware address (Empty in request)			
Destination protocol address			

Hardware type: The hardware field defines the type of link layer protocol, for ETHERNET this field is '1'.

Protocol type: this field defines the network layer protocol which is IPV4 and set to (0086)16

Hardware length: The hardware length field defines the length of hardware and set to (06)16

Protocol length: The field defines the length of protocol and set to (04)16.

Operation: For request the field is set to '1', For reply the field is set to '2'.

ARP operation using message exchange

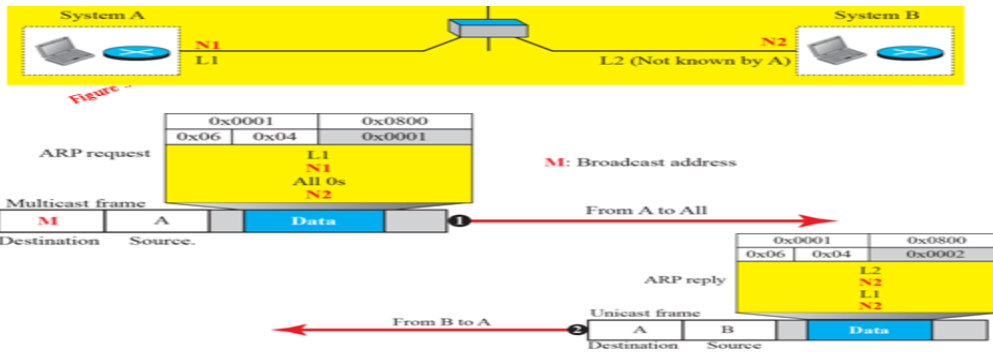

Q 5 a) Link Layer Addressing

- The physical address is updated each time as the frame moves from one node to next node (i.e. from hop to next hop or one link to next link).

Consider the figure

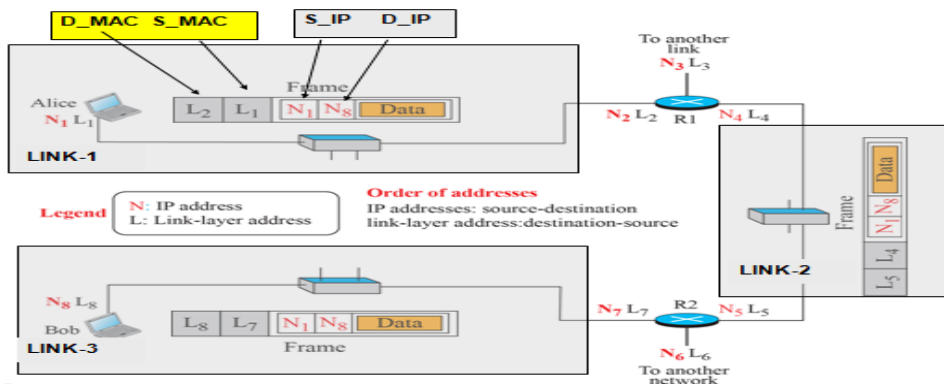

The data-link layer into two sublayers:

- Data link control (DLC)
- Media access control (MAC) as shown below

Q5 b) Services of data link layer

➤ The services performed by data-link layer are:

- 1) Framing: formation of frames.
- 2) Error control
- 3) Flow control

FRAMING

- The data link layer needs to pack bits into frames, so that each frame is distinguishable from another. Our postal system practices a type of framing. The simple act of inserting a letter into an envelope separates one piece of information from another; the envelope serves as the delimiter.
- Framing in the data link layer separates a message from one source to a destination, or from other messages to other destinations, by adding a sender address and a destination address i.e. the packet are appended with S_MAC address and D_MAC address.

Two types of Frames:

Fixed-Size Framing – no boundaries for frames, size used as the delimiter.

Variable-Size Framing – define beginning and end of frame, character oriented or bit oriented approach

Flow Control

Flow control refers to a set of procedures used to restrict the amount of data that the sender can send before waiting for acknowledgment

Error control:

Error control is both error detection and error correction. It allows the receiver to tell the sender of any frames lost or damaged in transmission and coordinates the retransmission of those frames by the sender.

Q 6 a) Switched Network

Switches:

- ✓ Devices which provide temporary connections to the linked devices.
- ✓ Switches moves or routes the data from one node to another node until they reach their destination without concerning with content of data.
 - Circuit switching
 - Message switching
 - Packet switching

Circuit switching:

- ❖ Communication via circuit switching has three phases:
 - ✓ Circuit establishment (link by link)
 - ✓ Data transfer
 - ✓ Circuit disconnect

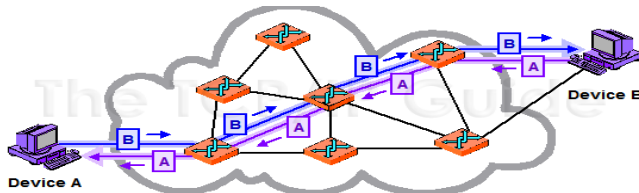

Packet switching

- ✓ Data are transmitted in short packets (typically at the order of 1000 bytes).
- ✓ Each packet contains a portion of user data plus some control info (addressing info).
- ✓ On each switching node, packets are received, stored briefly (buffered) and passed on to the next node.
- ✓ Packets belongs to the same message may take different route to reach to destination.
- ✓ Packets are routed based upon best possible path algorithm

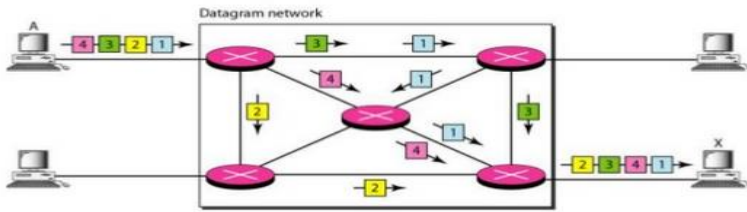

Q 6 b) Bit-Oriented Approach

- Bit oriented approach uses a special 8-bit pattern flag 01111110 as the delimiter to define the beginning and the end of the frame, as shown in Figure next.
- In a bit-oriented protocol, the data section of a frame is a sequence of bits to be interpreted by the upper layer as text, graphic, audio, video, and so on. However, in addition to headers and trailer (which store error detection and correction algorithm like cyclic redundancy check (crc)), we still need a delimiter or flag to separate one frame from the other.

Zero Bit-stuffing and destuffing

- If the data pattern resembles the flags pattern then receiver can mistaken it as flag. Hence a zero bit is stuffed at the transmitter after consecutive '5' ones called as zero bit stuffing.
- This stuffed zero bit is destuffed at the receiver back called as zero bit destuffing.

Zero Bit-stuffing and destuffing

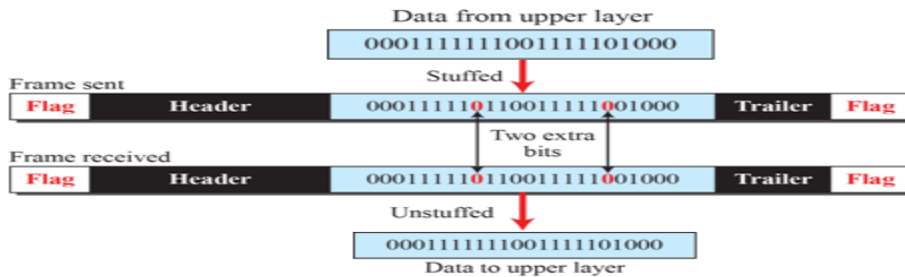

Q 7) Stop-and-Wait Protocol

- Here the sender sends one frame, stops until it receives agreement the receiver (okay to go ahead), and then sends the next frame. We still have unidirectional communication for data frames, but auxiliary ACK frames (simple tokens of acknowledgment) travel from the other direction. We add flow control to our previous protocol.

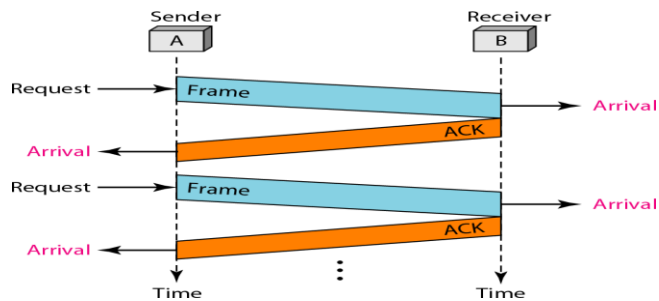

Procedures for error control and flow control in stop and wait protocol:

- 1) Installation of timers
- 2) Assigning of sequence number
- 3) Addition of crc information to frame

Installation of timers

- As soon as the frame is transmitted the timer starts and the ACK should arrive at transmitter before the timer expires.
- If the ACK is not received before the timer expires then the transmitter retransmit the frame thinking frame is lost or corrupted.
- But if ACK frame is lost and as the transmits the frame thinking the frame is corrupted or lost can lead to arriving of one duplicate frame at the receiver which need to be discarded.

Assigning of sequence numbers

- For flow control the sequence number are added to the frame in the order of 0,1,0,1,0...
- For example if 'frame 0' is transmitted then receiver sends 'ACK1' indicating that the 'frame 0' is successfully received and now waiting for next 'frame 0'.

The addition of sequence number also helps receiver in discarding the duplicate frame as shown in figure.

Adding CRC information

The sender sends one frame, stops until it receives agreement the receiver (okay to go ahead), and then sends the next frame. Hence for error control the 'CRC' information is added to frame itself which is verified at the receiver.

CRC information is a kind of key which is shared to both transmitter and receiver. Receiver checks the error information using this key.

Flow Diagram

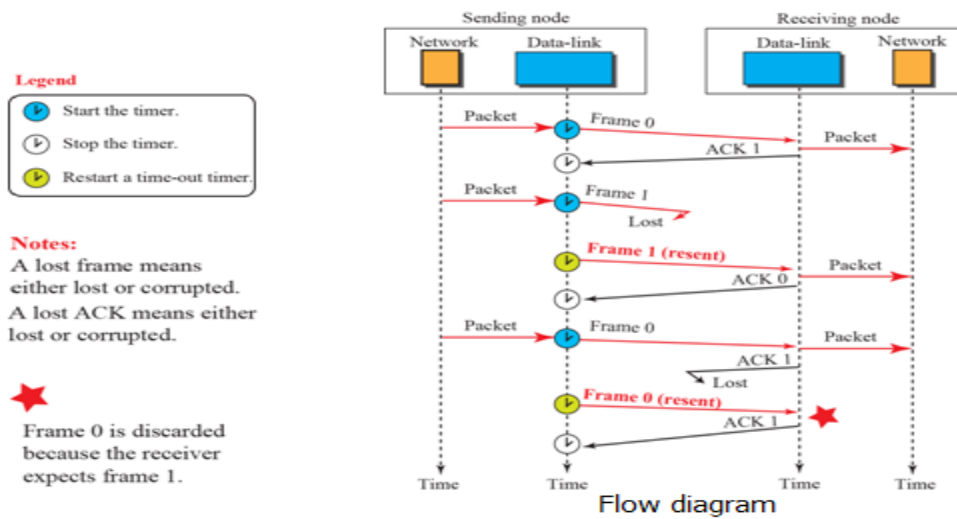

USN

--	--	--	--	--	--	--	--	--	--	--



Internal Assessment Test 1 – March. 2019

Sub:	Computer Communication Networks					Sub Code:	15EC64	Branch	TCE	
Date:	/03/2019	Duration:	90 min's	Max Marks:	50	Sem / Sec:	A		OBE	
<u>Answer any five question from each part</u>								MARKS	CO	RBT
1	(a) Explain the major components of data communication with a neat diagram.					[5+5]	CO1	L2		
	(b) Explain network topologies also mention merits and demerits.									
2	Explain protocol layering with the principles. With a neat diagram explain the TCP/IP protocol model with respect to layers protocols.					[10]	CO1	L2		
3	Compare TCP/IP and OSI reference model and also explain different addressing schemes.					[10]	CO1	L2		
4	What is Address Resolution Protocol (ARP)? Explain ARP packet format and caching with neat diagrams.					[2+4+4]	CO1	L1		
5	(a)What is link layer addressing? Explain with an example.					[3+7]	CO1	L2		
	(b)Explain the services of data link layer.									
6	(a)What switching? Explain circuit and packet switching with neat diagrams.					[5+5]	CO1	L1		
	(b) Explain bit stuffing and destuffing with necessary figure.									
7	Explain stop and wait protocol with neat figures.					[10]	CO1	L1		

Course Instructor
Instructor

Chief Course