

CBCS SCHEME

15CV81



Eighth Semester B.E. Degree Examination, November 2020 Quantity Surveying and Contract Management

Max. Marks: 80

Note: Answer any FIVE full questions irrespective of modules.

Module-1

- 1 The details of a residential building is shown in Fig.Q1. Estimate the quantities and cost of each item of works.
- (i) Earthwork in excavation for Foundation in hard soil @ Rs. 380/m³.
 - (ii) Plain cement concrete 1 : 3 : 6 for bed of the foundation @ Rs. 3000/m³.
 - (iii) Size stone masonry with CM 1 : 6 for footings and basement @ Rs. 2200 / m³
 - (iv) First class Brickwork with burnt brick masonry CM 1:6 in super structure @ Rs. 4500/-

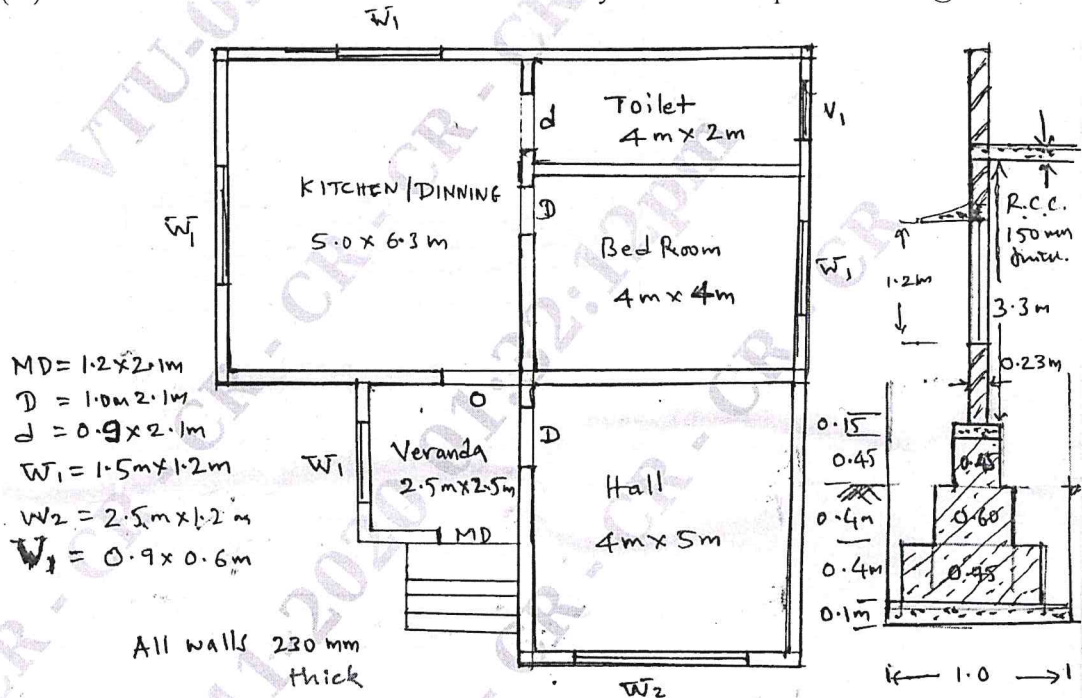

Fig.Q1

CMRIT LIBRARY (16 Marks)
BANGALORE - 560 037

- 2 Explain the purpose of estimation. List any two types of estimates and explain. (16 Marks)

Module-2

- 3 The details of septic tank are shown in Fig.Q2. Estimate the quantities of follows item and cost.
- (i) Earth work in excavation @ Rs. 380/m³
 - (ii) P.C.C. 1:3:6 for bed @ Rs. 3000/m³
 - (iii) BBM in CM 1:4 for all walls @ 4500/m³
 - (iv) R.C.C. 1 : 1.5 : 3 for cover of the tank @ Rs. 5500/m³.

Important Note : 1. On completing your answers, compulsorily draw diagonal cross lines on the remaining blank pages.
2. Any revealing of identification, appeal to evaluator and /or equations written eg, 42+8 = 50, will be treated as malpractice.

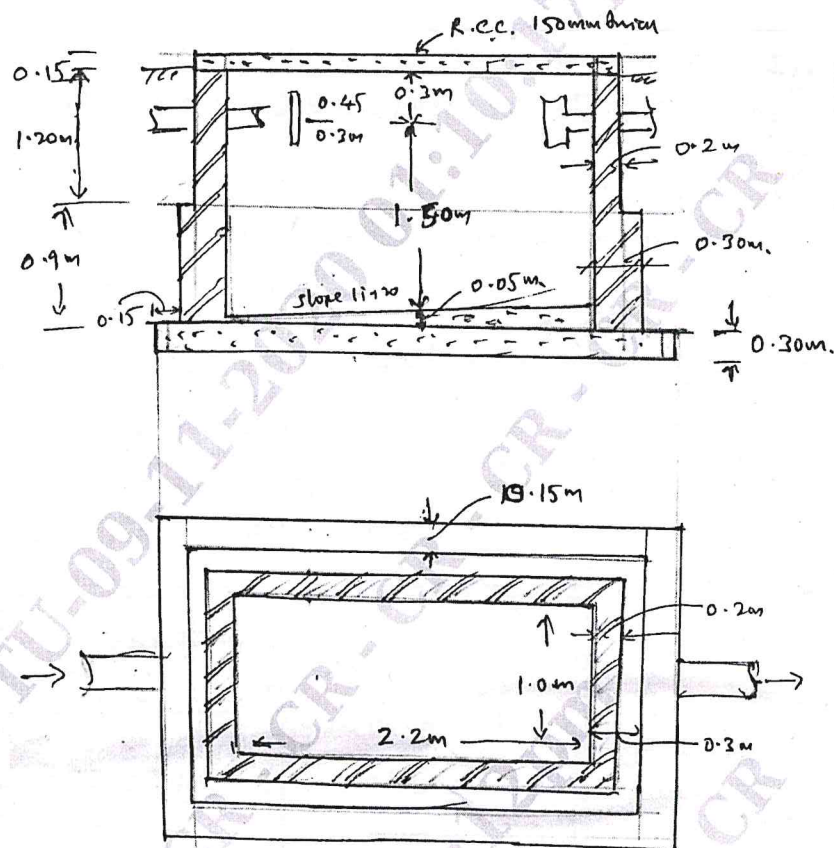

Fig.Q2

(16 Marks)

- 4 Reduced levels of ground along a proposed road is given in the table the formation level at 1st chain is 108 and the road is in downward gradient of 1:150 up to the chainage four and then gradient changes to 1 : 100 downward formation width of road is 10m side slopes 2:1(H:V) Length of chain 30m. Estimate the quantities of earthwork.

Chainage	0	1	2	3	4	5	6	7	8	9	10
RL of ground	106	106.6	106.44	106.9	106.42	105.3	106	105.1	105.62	105	104.3

(16 Marks)

Module-3

- 5 Write detailed specifications for following :
- Plain cement concrete in bed of foundation
 - Size stone masonry in CM 1:6
 - Reinforced cement concrete M₂₀ grade (1 : 1½ : 3)
 - Painting plastered surface including preparation of surface.
- (16 Marks)
- 6 Carry out the Rate Analysis for
- Plain cement concrete 1 : 3 : 6
 - Burnt Brick Masonry in CM 1 : 6.
 - Plastering with cement mortar CM 1 : 4
 - Painting the cement plastered walls with 2 coats putty and 2 coats paint.
- (16 Marks)

CMRIT LIBRARY
RANGALORE - 560 037

15CV81

Module-4

- 7 What is Tender? Explain the departmental procedure of tendering civil works. (16 Marks)
- 8 Explain (i) Prequalification
(ii) Bid submission and Evaluation process
(iii) Law of contract
(iv) Contract forms. (16 Marks)

Module-5

- 9 Explain (i) Mobilization and equipment advance
(ii) Secured advance
(iii) Liquidated damages and bonus
(iv) Dispute resolution mechanism. (16 Marks)
- 10 What is valuation? Explain the methods of valuation of buildings. (16 Marks)

* * * * *

CMRIT LIBRARY
BANGALORE - 560 037

