

CBCS SCHEME

15CIV13/23

First/Second Semester B.E. Degree Examination, Jan./Feb.2021
Elements of Civil Engineering and Engineering Mechanics

Time: 3 hrs.

Max. Marks: 80

Note: Answer any FIVE full questions, choosing ONE full question from each module.

Module-1

- 1 a. Explain briefly different types of infrastructure to be provided in the development of an area. (06 Marks)
b. Explain classification of Roads in India. (06 Marks)
c. Define Couple and explain its characteristics. (04 Marks)

OR

- 2 a. Explain briefly the scope of the following Civil Engineering field :
i) Geotechnical Engineering ii) Environmental Engineering. (06 Marks)
b. With neat sketch, explain different parts of a bridge. (04 Marks)
c. Determine the angle α for which the moment of the 500N force shown in Fig.Q2(c) is maximum about O. Also find the maximum moment. (06 Marks)

Fig.Q2(c)

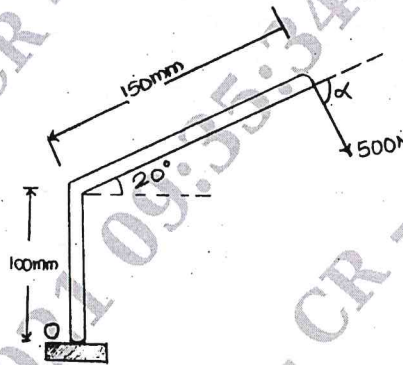

Module-2

- 3 a. State and prove parallelogram law of forces. (08 Marks)
b. If the resultant of the two forces shown in Fig.Q3(b) is 700N directed vertically upwards, find the angles α and β . (08 Marks)

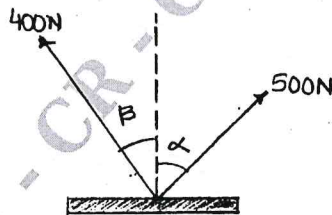

Fig.Q3(b)

OR

Important Note : 1. On completing your answers, compulsorily draw diagonal cross lines on the remaining blank pages.
2. Any revealing of identification, appeal to evaluator, will be treated as malpractice.

- 4 a. Explain with sketches i) Angle of repose ii) Cone of friction. (04 Marks)
 b. A rigid plate is subjected to the forces shown in Fig.Q4(b), compute resultant of forces and position of resultant force with respect to centroid point 'O' of the plate. (06 Marks)

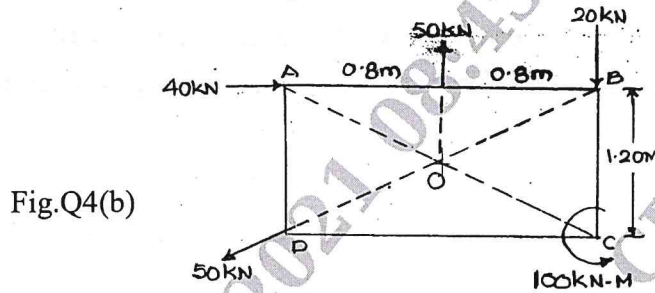

Fig.Q4(b)

- c. Compute the tensions in the strings AB, BC, CD shown in Fig.Q4(c). (06 Marks)

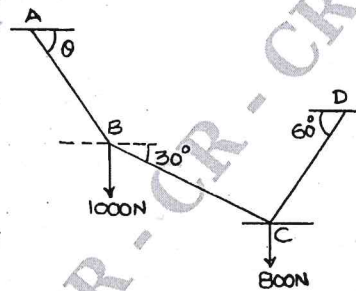

Fig.Q4(c)

CMRIT LIBRARY
BANGALORE - 560 037

Module-3

- 5 a. State and prove Varignon's theorem. (05 Marks)
 b. Explain different types of beams. (06 Marks)
 c. Determine the support reactions of the beam shown in Fig.Q5(c). (05 Marks)

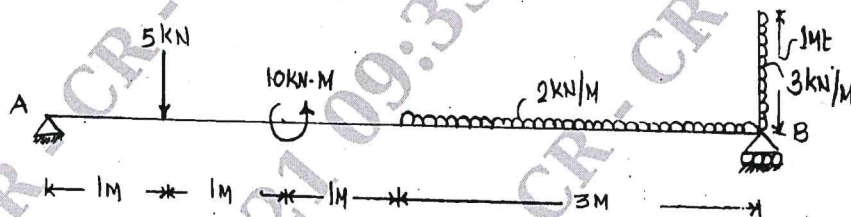

Fig.Q5(c)

OR

- 6 a. Cylinder A of diameter 200mm and cylinder B of diameter 300mm are placed in a trough shown in Fig.Q6(a). If cylinder A weighs 800N and cylinder B weighs 1200N. determine the reaction developed at contact surfaces P, Q, R and S. Assume all contact surfaces are smooth. (08 Marks)

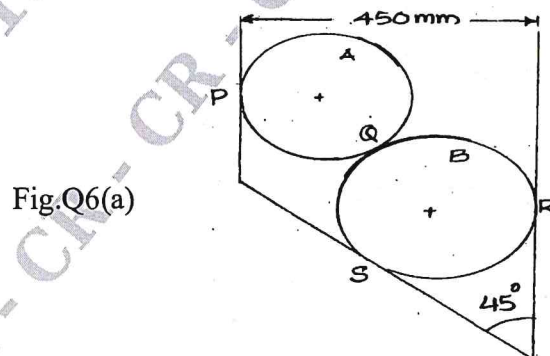

Fig.Q6(a)

- b. Determine the distance 'X' such that the reactions R_A and R_B are equal for the beam shown in Fig.Q6(b). (08 Marks)

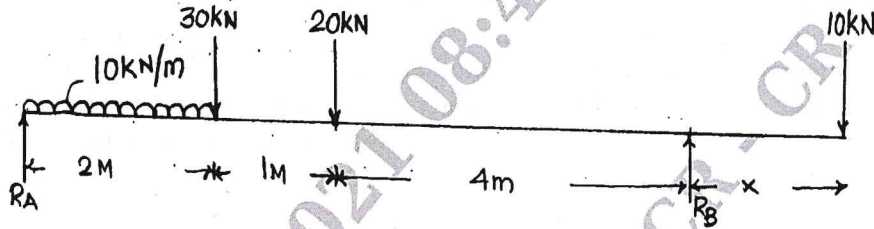

Fig. Q6(b)

Module-4

- 7 a. State and prove Parallel axes theorem. (08 Marks)
 b. Determine the centroid of the lamina shown in Fig.Q7(b) with respect to the axes shown. (08 Marks)

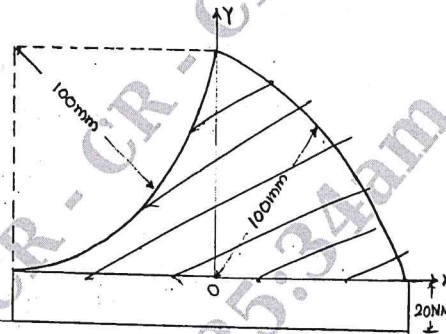

Fig. Q7(b)

OR

- 8 a. Determine the moment of Inertia of the shaded area shown in Fig.Q8(a) about X - X axis. (08 Marks)

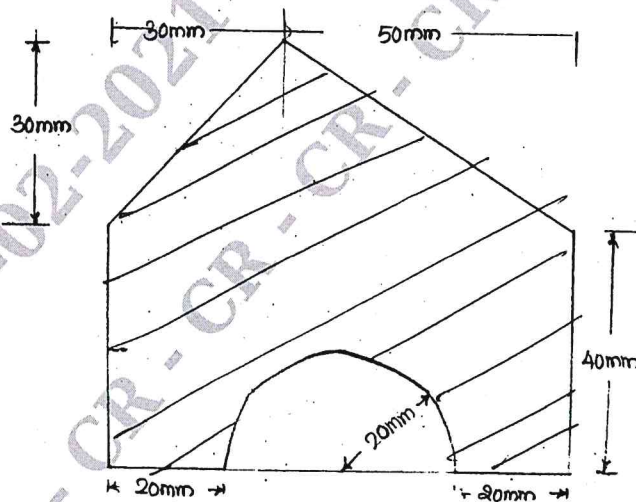
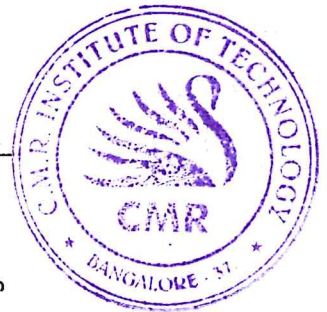

Fig. Q8(a)



- b. Derive the expression for centroid of a quarter of a circle by method of Integration. (08 Marks)

Module-5

- 9 a. What is Super Elevation and What is its necessity? (04 Marks)
b. Define i) Displacement ii) Acceleration. (04 Marks)
c. Two trains A and B leave the same station on parallel lines. A starts with a uniform acceleration of 0.15m/sec^2 and attains the speed of 24km/hr after which its speed remains constant. B leaves 40 seconds later with uniform acceleration of 0.30m/sec^2 to attain a maximum speed of 48km/hour . Its speed also becomes constant thereafter. When will B overtake A? (08 Marks)

OR

- 10 a. A stone is dropped from the top of a tower. When it has fallen a distance of 10m , another stone is dropped from a point 38m below the top of the tower. If both the stones reach the ground at same time, calculate i) the height of the tower ii) the velocity of the stones when they reach the ground. (08 Marks)
b. A ball is projected vertically upwards with a velocity of 20m/sec . Two seconds later, a second ball is projected vertically upwards with a velocity of 16m/sec . Find the height above the surface at which the two balls meet. (08 Marks)

CMRIT LIBRARY
BANGALORE - 560 037
