

CBCS SCHEME

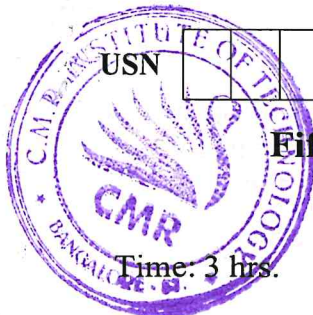

USN

--	--	--	--	--	--	--	--

18CV52

Fifth Semester B.E. Degree Examination, Jan./Feb. 2021 Analysis of Indeterminate Structures

Time: 3 hrs.

Max. Marks: 100

Note: Answer any FIVE full questions, choosing ONE full question from each module.

Module-1

- 1 Analyze the continuous beam shown in Fig.Q1 by slope deflection method. Draw BMD, SFD and elastic curve.

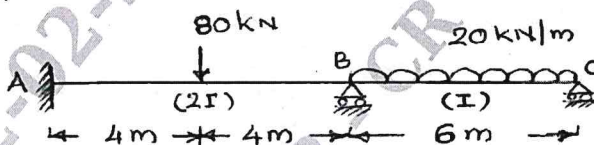

Fig.Q1

(20 Marks)

OR

- 2 Analyze the portal frame shown in Fig.Q2 by slope deflection method. Draw BMD and elastic curve.

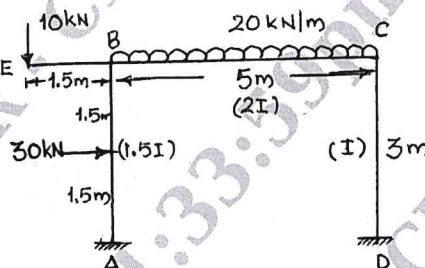

Fig.Q2

(20 Marks)

Module-2

- 3 Analyze the continuous beam shown in Fig.Q3 by using moment distribution method. Draw BMD SFD and elastic curve the support B sinks by 1 cm. Take $EI = 500 \text{ kN-m}^2$.

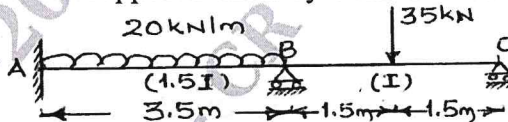

Fig.Q3

(20 Marks)

OR

- 4 Analyze the portal frame shown in Fig.Q4 by moment distribution method. Draw BMD, SFD and elastic curve.

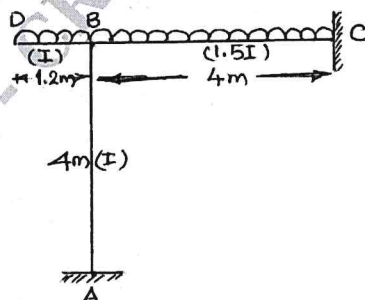

Fig.Q4

(20 Marks)

Module-3

- 5 Analyze the continuous beam shown in Fig.Q5 by using Kani's method. The support C sinks by 20 mm. Take $E = 200 \text{ kN/mm}^2$, $I = 170 \times 10^6 \text{ mm}^4$. Draw BMD, SFD and EC.

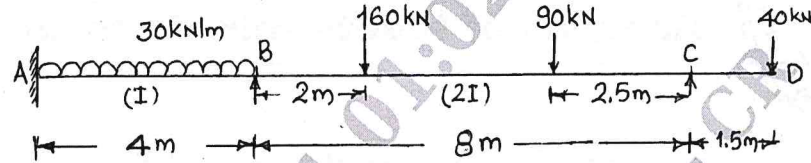

Fig.Q5

(20 Marks)

OR

- 6 Analyze the portal frame shown in Fig.Q6 by using Kani's method. Assume EI is constant throughout. Draw BMD and elastic curve.

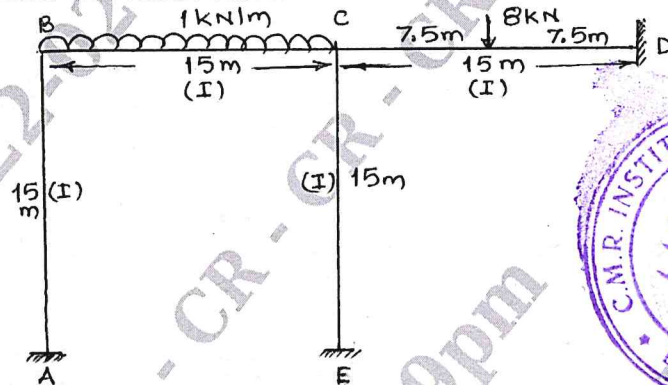
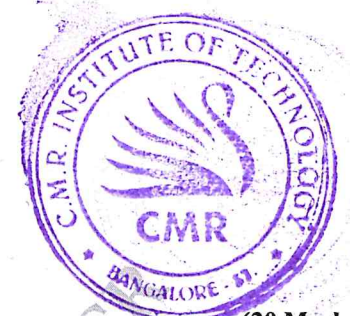

Fig.Q6

(20 Marks)



Module-4

- 7 Analyze the continuous beam by using flexibility matrix method. Draw BMD, SFD and elastic curve. Refer Fig.Q7.

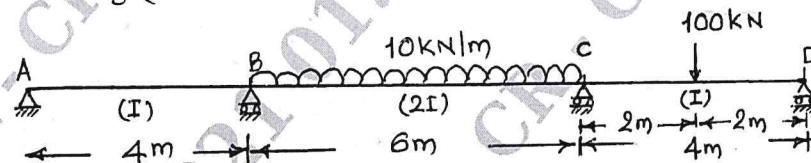

Fig.Q7

(20 Marks)

OR

- 8 Analyze the truss shown in Fig.Q8 by flexibility matrix method choosing force in the member AD as redundant. Assume constant EI for all the members.

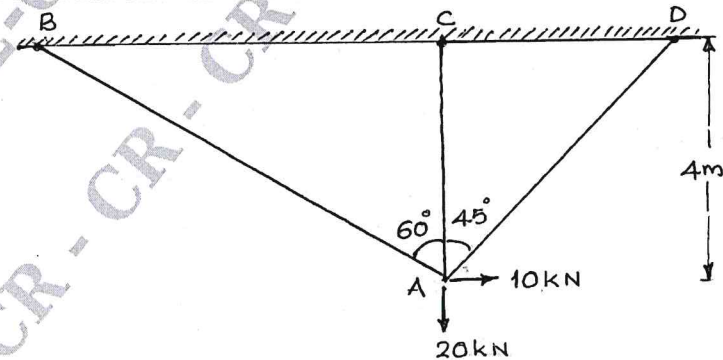

Fig.Q8

(20 Marks)

Module-5

- 9 Analyze the continuous beam shown in Fig.Q9 by using stiffness matrix method. Draw BMD, SFD and elastic curve.

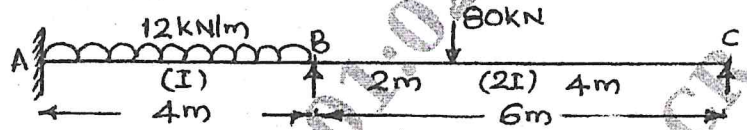

Fig.Q9

(20 Marks)

OR

- 10 Analyze the portal frame shown in Fig.Q10 by stiffness matrix method. Draw BMD and elastic curve.

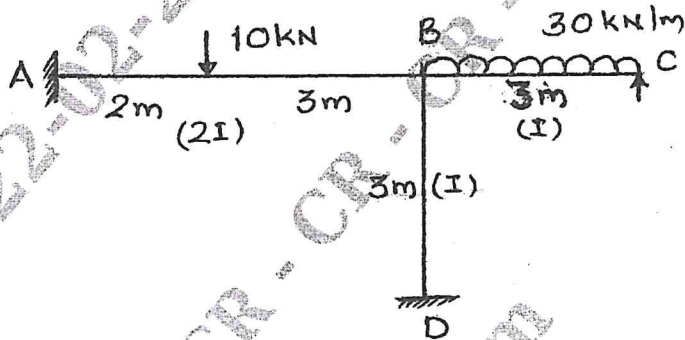

Fig.Q10

(20 Marks)

