

VISVESVARAYA TECHNOLOGICAL UNIVERSITY

Jnana Sangama, Belgaum-590018



A PROJECT REPORT (15CSP85) ON

“ACCIDENT DETECTION AND ALERT SYSTEM”

Submitted in Partial fulfillment of the Requirements for the Degree of
Bachelor of Engineering in Computer Science & Engineering

By

KETHU NIKHIL KUMAR REDDY(1CR16CS071)

MADA NIKSHITH REDDY (1CR16CS078)

MANDALI VENKATA VAMSIDHAR (1CR16CS080)

MARIA RASHMIS(1CR16CS085)

Under the Guidance of,

Prof . Manoj Challa,

Associate Professor, Dept. of CSE



DEPARTMENT OF COMPUTER SCIENCE AND ENGINEERING

CMR INSTITUTE OF TECHNOLOGY

#132, AECS LAYOUT, IT PARK ROAD, KUNDALAHALLI, BANGALORE-560037

CMR INSTITUTE OF TECHNOLOGY

#132, AECS LAYOUT, IT PARK ROAD, KUNDALAHALLI, BANGALORE-560037

DEPARTMENT OF COMPUTER SCIENCE AND ENGINEERING



CERTIFICATE

Certified that the project work entitled “**ACCIDENT DETECTION AND ALERT SYSTEM**” carried out by **Mr. KETHU NIKHIL KUMAR REDDY USN:1CR16CS071**, **Mr. MADA NIKSHITH REDDY, USN 1CR16CS078**, **Mr. MANDALI VENKATA VAMIDHAR, USN 1CR16CS080**, **Ms. MARIA RASHMLS, USN 1CR16CS085**, bonafide students of CMR Institute of Technology, in partial fulfillment for the award of **Bachelor of Engineering** in Computer Science and Engineering of the Visveswaraiah Technological University, Belgaum during the year 2019-2020. It is certified that all corrections/suggestions indicated for Internal Assessment have been incorporated in the Report deposited in the departmental library.

The project report has been approved as it satisfies the academic requirements in respect of Project work prescribed for the said Degree.

Prof. Manoj Challa
Associate Professor
Dept. of CSE, CMRIT

Dr. Prem Kumar Ramesh
Professor & Head
Dept. of CSE, CMRIT

Dr. Sanjay Jain
Principal
CMRIT

DECLARATION

We, the students of 8th semester of Computer Science and Engineering, CMR Institute of Technology, Bangalore declare that the work entitled "**Accident Detection and Alert System**" has been successfully completed under the guidance of Prof. Manoj Challa, Computer Science and Engineering Department, CMR Institute of technology, Bangalore. This dissertation work is submitted in partial fulfillment of the requirements for the award of Degree of Bachelor of Engineering in Computer Science and Engineering during the academic year 2019 - 2020. Further the matter embodied in the project report has not been submitted previously by anybody for the award of any degree or diploma to any university.

Place:

Date:

Team members:

KETHU NIKHIL KUMAR REDDY (1CR16CS071)

MADA NIKSHITH REDDY (1CR16CS078)

MANDALI VENKATA VAMSIDHAR (1CR16CS080)

MARIA RASHMI S(1CR16CS085)

ABSTRACT

Speed is one of the basic reasons for vehicle accident. Many lives could have been saved if emergency services could get accident information and reach in time. This project deals with accident detection system when the accident occurs it uses various components and alerts the Rescue team for help. An efficient automatic accident detection with an automatic notification to the emergency service with the accident location is a prime need to save the precious human life. The proposed system deals with accident alerting and detection. It reads the exact latitude and longitude of the vehicle involved in the accident and sends this information to nearest emergency service provider. The goal of the project is to detect accidents and alert the rescue team in time.

ACKNOWLEDGEMENT

I take this opportunity to express my sincere gratitude and respect to **CMR Institute of Technology, Bengaluru** for providing me a platform to pursue my studies and carry out my final year project

I have a great pleasure in expressing my deep sense of gratitude to **Dr. Sanjay Jain**, Principal, CMRIT, Bangalore, for his constant encouragement.

I would like to thank **Dr. Prem Kumar Ramesh**, HOD, Department of Computer Science and Engineering, CMRIT, Bangalore, who has been a constant support and encouragement throughout the course of this project.

I consider it a privilege and honor to express my sincere gratitude to my guide **Prof. Manoj Challa, Associate Professor**, Department of Computer Science and Engineering, for the valuable guidance throughout the tenure of this review.

I also extend my thanks to all the faculty of Computer Science and Engineering who directly or indirectly encouraged me.

Finally, I would like to thank my parents and friends for all their moral support they have given me during the completion of this work.

TABLE OF CONTENTS

	Page No.
Certificate	ii
Declaration	iii
Abstract	iv
Acknowledgement	v
Table of contents	vi
List of Figures	viii
List of Tables	ix
1 INTRODUCTION	1-5
1.1 Relevance of the Project	1
1.1.1 Block Diagram	2
1.1.2 Agile Methodology	3
1.2 Scope of the Project	3
1.3 Objectives	4
1.4 Methodology	4
1.5 Problem Statements	4
1.6 Existing System	5
1.7 Proposed System	5
2 LITERATURE SURVEY	7-10
2.1 Research and Technical Papers	7
3.2 Comparison between Research Papers	10
3 SYSTEM REQUIREMENTS SPECIFICATION	11-17
3.1 Functional Requirements	11
3.2 Non-Functional requirements	11
3.3 Hardware Requirements	12
3.4 Software Requirements	16

4	SYSTEM ANALYSIS AND DESIGN	18-19
	4.1 System Design	18
	4.2 Flow Chart	18
	4.3 Use Case Diagram	19
5	IMPLEMENTATION	20-25
	5.1 Proposed Algorithm	
	5.2 Code used	
6	RESULTS AND DISCUSSION	26
7	TESTING	27-30
	7.1 Reading data from Arduino	27
	7.2 Location data reading from GPS module	28
	7.3 Sending alert message by GSM	29
8	CONCLUSION AND FUTURE SCOPE	31
	8.1 Conclusion	
	8.2 Contribution	
	8.3 Future scope	
	REFERENCES	32

LIST OF FIGURES

Figures	Page No.
Fig 1 Block diagram of the circuit	2
Fig 2 Block diagram of GSM	12
Fig 3 Block diagram of GPS	13
Fig 4 Block diagram of Arduino	14
Fig 5 Block diagram of Accelerometer	14
Fig 6 Block diagram of Gyroscope	15
Fig 7 Block diagram of Vibration sensor	16
Fig 8 System design	18
Fig 9 Flowchart	18
Fig 10 Use case diagram	19
Fig 11 Interfacing controller with all other module	26
Fig 12 Alert message	26
Fig 13 Testing of Arduino	27
Fig 14 Testing of GPS module	28
Fig 15 Testing of GSM	29
Fig 16 Testing of Accident detection	30

LIST OF TABLES

	Page No.
Table 1.1 Agile Methodology	3
Table 2.2 Comparison between Research Papers	10

LIST OF ABBREVIATIONS

GSM	Global System for mobile Communication
GPS	Global Positioning System
GPRS	General Packet Radio Service
PCB	Printed Circuit Board

CHAPTER 1

INTRODUCTION

The development of a transportation system has been the generative power for human beings to have the highest civilization above creatures in the earth. Automobile has a great importance in our daily life. We utilize it to go to our work place, keep in touch with our friends and family, and deliver our goods. But it can also bring disaster to us and even can kill us through accidents. Speed is one of the most important and basic risk factors in driving. It not only affects the severity of a crash, but also increases risk of being involved in a crash.

Despite many efforts taken by different governmental and non-governmental organizations all around the world by various programs to aware against careless driving, yet accidents are taking place every now and then. However, many lives could have been saved if the emergency service could get the crash information in time. A study by Virtanen et al. shows that 4.6% of the fatalities in accidents could have been prevented only if the emergency services could be provided at the place of accident at the proper time. As such, efficient automatic accident detection with an automatic notification to the emergency service with the accident location is a prime need to save the precious human life.

1.1 Relevance of the Project

- The accidental detection and alert system are designed to detect the accidents and alert rescue team in time.
- Arduino is major control unit to communicate between devices when an accident occurs, which helps in transferring messages to different devices in the system.
- Receiving pin of GSM module and transmitting pin of GPS module are used to communication.
- GPS module will find the location of the vehicle and the information is fetched by the receiver through the coordinates and the received data is sent to Arduino and the alert to rescue team by GSM module.

- The accelerometer and gyroscope detect the accident occurrence by the reading produced by the movements of the vehicle.
- The vibration sensor is also used to detect the accident by producing voltage from the impact of vehicle movements.

1.1.1 Block Diagram

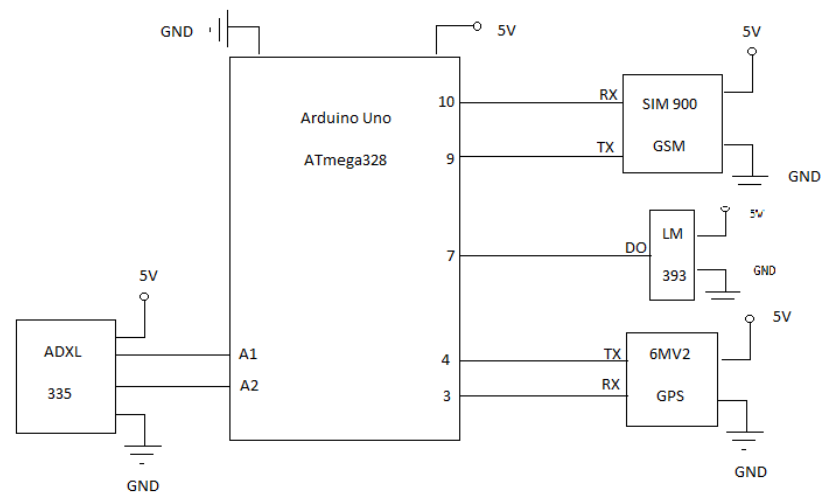

Fig 1: Block diagram of the circuit

1.1.2 Agile Methodology or Summary of approaches

Story ID	Requirements Description	User Stories/task	Description
1.	Prediction of Sudden Speed Drop	As a project developer we should design to detect the speed changes using Accelerometer	Piezoelectric effect and meter readings.
2.	Confirmation of Accident	Getting alerts through accelerometer data one should confirm whether accident occurred or not	Switches
3.	GPS Co-ordinates	Upon the confirmation of accident, it should get the GPS co-ordinates from module	Trilateration
4.	SMS through GSM	Sends the GPS co-ordinates to nearby hospitals through GSM module	Cellular Technology

1.2 Scope of the Project

- The scope of the project is to design an accidental detection system that detect the accidents and alert rescue team in time.
- Arduino is major control unit to detect or alert when an accident occurs, which helps in transferring messages to different devices in the system.
- Receiving pin of GSM module and transmitting pin of GPS module are used to communication
- GPS module will find the location of the vehicle and the information is fetched by the receiver through the coordinates and the received data is sent to Arduino and the alert to rescue team by GSM module.

1.3 Objectives

- The objective is to overcome accidents by monitoring any change in the speed of the vehicle whereas the accelerometer can detect the fall.
- The Arduino is the major control unit to detect or alert when an accident occurs. It collects the data from the accelerometer, GPS, GSM modules and reflects the output.
- This will reach the rescue service in time and save lives.

1.4 Methodology

- Monitoring the speed of the vehicle and detecting if there is any sudden drop in the speed of the vehicle.
- Arduino UNO is used as controlling unit, it reads the values from accelerometer. Accelerometer detects if there is any fall in axis.
- If Arduino observes any drastic change in the speed of the vehicle. It reads the current location from GPS module and sends it to the mobile number through SMS by using GSM module.
- Before sending the SMS Arduino activates the buzzer, after thirty seconds of beeping it goes off and the SMS will be sent.
- But if the passenger is not in danger, he can press the “IAM OKAY” button. This is done to prevent the situations where it would lead false accident rescue.

1.5 Problem Statements

- The goal of the project is to detect accidents and alert the rescue team in time.
- The gap between the existing systems in place and the ideal system is that automated system is used once the accident occurs which can give latitude and longitude of accident occurred area without delay. More Human life can be saved using this system.

1.6 Existing System

Many researchers carried out their studies on accident detection system. Traditional traffic accident prediction uses long-term traffic data such as annual average daily traffic and hourly volume. In contrast to traditional traffic accident prediction, real-time traffic accident prediction relates accident occurrences to real-time traffic data obtained from various detectors such as induction loops, infrared detector, camera etc. Real-time traffic accident prediction focuses on the change of traffic conditions before an accident occurrence, while traffic incident detection studies are concerned with the change of traffic conditions after an incident occurrence. However, the performance of these detection and prediction system is greatly restricted by the number of monitoring sensor, available fund, algorithms used to confirm an accident, weather, traffic flow etc.

Besides the automatic detection system, manual incident detection methods detects the accident from the motorist report, transportation department or public crews report, aerial surveillance or close circuit camera surveillance. The drawback of this type of detection system is that someone has to witness the incident. Moreover, there are delays and inaccuracies due to the expression problem of the witness. Compared to these detection method, driver initiated incident detection system has more advantages which includes the quick reaction, more incident information etc. However, with the severity of the accident, driver may not be able to report at all.

Conventional built-in automatic accident detection system utilizes impact sensor or the car airbag sensor to detect an accident and GPS to locate the accident place.

1.7 Proposed System

- Arduino Nano is used as controlling unit, communicating between modules for better information transformation at time.
- Accelerometer can be used for detecting the collision direction from tri-lateral axis movements.
- Gyroscope can be used for rollover collisions after a threshold of roll and pitch values, the weight and centre of gravity of vehicle plays an important role in rollover.

- The device also confirms from vibration sensors which detects the collision after a threshold voltage increase.
- Then a buzzer is provided to abort the false detection of accident to the passenger.
- Within of limited time of buzzer signal the GPS module collects the coordinates from Google Module.
- These co-ordinates nearby hospitals are alerted for emergency rescue call to passenger.
- The hospital approves the accident by verifying the accident at specified location and confirms the accident.
- The saved personal members of family are informed regarding the accident through GSM module.

CHAPTER 2

LITERATURE SURVEY

2.1 RESEARCH AND TECHNICAL PAPERS

2.1.1 ACCIDENT DETECTION AND REPORTING SYSTEM USING GPS, GPRS AND GSM TECHNOLOGY (@2012 IEEE):

This paper proposes to utilize the capability of a GPS receiver to monitor the speed of a vehicle and detect an accident basing on the monitored speed and send the location and time of the accident from GPS data processed by a micro-Controller by using the GSM network to the Alert Service Centre.

At high speeds the distance between starting to brake and a complete stand still is longer. The braking distance is proportional to the square of speed. Therefore, the possibility to avoid a collision becomes smaller.

There is a tabular column for predicting the maximum speed after considering the deceleration factors. As such, if the speed is less than these maximum speeds, than it would be assumed that some other deceleration force worked on the vehicle to reduce the speed and an accident has occurred.

Speedometer can also be used to find the speed drops in vehicles, but an analogue to digital converter is required to acquire speed from it. So, a GPS is used to track the speed of vehicle every instance.

The vehicle speed is calculated at every instance by GPS. If there is decrease in new speed values then it raises an ALARM for accident detection. Then 5 secs will be given to abort the emergency Else the emergency is sent to Alert Service Centre and plot the location of accident by the GSM number received. There after rescuing the individual.

2.1.2 REAL TIME DETECTION AND REPORTING OF VEHICLE COLLISION (@2017 IEEE):

This paper proposes to utilize the capability of Accelerometer and Gyroscope to obtain the data and detect an accident basing on the orientation angle and orientation. Then send the location of the accident from GPS data processed by a micro-Controller by using the GSM network to the nearest hospital provided over the network and alerts their family members too.

The accelerometer detects the direction of vehicle collision by bi-directional axis and an axis towards gravitational force with full scale +/-8g. The collision of a vehicle leads to a drastic change in vehicle speed and shows a direct impact on acceleration force along that axis of crash. As the Z-axis is oriented along the gravitational force direction, only X-axis and Y-axis of accelerometer is required to determine the happening and direction of vehicle collision.

The gyroscope is used to calculate the tilt of collision vehicle and is given a full range of +/-500 degree/sec. Angle greater above 46 degree and below -46-degree results in rollover of car. Other than the threshold f roll and pitch values, the weight and centre of gravity of vehicle plays an important role in rollover. Once the threshold is reached, the notification system will be activated informing the family and nearby hospital about the occurrence of vehicle rollover.

In addition, they use GPS tracker too for recording false assumptions from the GPS data acquired.

The notification system notifies the information to family emergency contacts and nearest hospital. Notification system is activated once the threshold for detection is reached. Location is identified by GPS.

2.1.3 VEHICLE ACCIDENT DETECTION SYSTEM BY USING GSM, GPS AND SENSORS (@2019, IRJET):

This paper proposes to utilize the capability of a Piezoelectric sensor to detect an accident basing on the voltage produced by collision and send the location and time of the accident from GPS data processed by a micro-Controller by using the GSM network to the Alert Service Centre.

The Piezoelectric sensor produces a DC voltage proportional to impacts on collision on vehicle. When the voltage increases above threshold value the sensors get triggered.

The Latitude and Longitude are detected using GPS and it is sent as message to rescue team through GSM module. The message is received by another GSM module. Google Map Module: It displays Google map shows you exact location of accident and its details. It gets detail SMS from accident location. Hence there is small variation in co-ordinates .An OFF switch is also provided at times of need to avoid false message.

2.2 COMPARISON BETWEEN RESEARCH PAPERS

	Research/Technical Paper	Process	Advantage
Approach 1	Accident Detection using GPRS,GPS and GSM Technology IEEE @2012	Detects the accident through GPRS and location is sent over GSM to mobile through GPS	Just detects the location of accidents and alerts to mobile
Approach 2	Accident Detection using GPS , GSM, Gyroscope and Accelerometer IEEE 2017	Detects the location of accident by detecting the changes in orientation levels of accelerometer.	Detects the collision directions by accelerometer.
Approach 3	Accident Detection and Prevention by switches Instructables.com	Detects the accident and confirms for the accident	It asks for the passenger confirmation of accident through 2 way switch
Approach 4	Read Time Detection using Vibration Sensor IRJET 2019	Detects the accident by voltage generated through sensors by collision.	Sending of location to nearby hospitals through network.

CHAPTER 3

SYSTEM REQUIREMENTS SPECIFICATION

This Chapter describes about the requirements. It specifies the hardware and software requirements that are in order to run the system properly. The Hardware Requirement Specification is explained in detail, which includes the overview of functional and non-functional requirements.

3.1 Functional Requirements

Functional Requirements defines the function of the system and gives the outline of what the system does.

- Auto detection mode is the identifier it holds the purpose of automatically detects when the accident occurs and it also sends the alert. The pre-condition is that turning on auto detection mode and the post-condition is On detection of accident and alert message will be sent.
- Adding emergency contacts it specifies the contacts that has to be saved, the purpose of doing so helps in sending the alert message when the accident occurs.
- Sending the Alert message this requires the emergency contacts to be saved. It involves the action to be performed when the emergency message pops up.

3.2 Non-Functional Requirements

Non-functional requirements are the requirements which are not directly concerned with the specific function delivered by the system. They specify the criteria that can be used to judge the operation of a system rather than specific behaviours.

The designed system will respond when the accident occurs it uses the proposed methodology of this project in detecting the accident, the detection depends on the speed of GPS in order to locate the spot and send the alert to medical emergency using the GSM module.

3.3 Hardware Requirements

- Arduino
- GPS module
- GSM module
- Accelerometer and Gyroscope
- Vibration Sensor
- Power Supply
- Connecting Wires
- Breadboard or PCB

3.3.1 Working of GSM

For providing communication between the GPS, GSM and the allocated mobile number GSM SIM900 module is preferred. The name SIM900 says that, it is a tri band work ranging a frequency of 900MHz to 1900 MHz such as EGSM900 MHz, PCS 1900 MHz and DSC 100 MHz Receiving pin of GSM module and transmitting pin of GPS module are used for communication between the modules and the mobile phone.

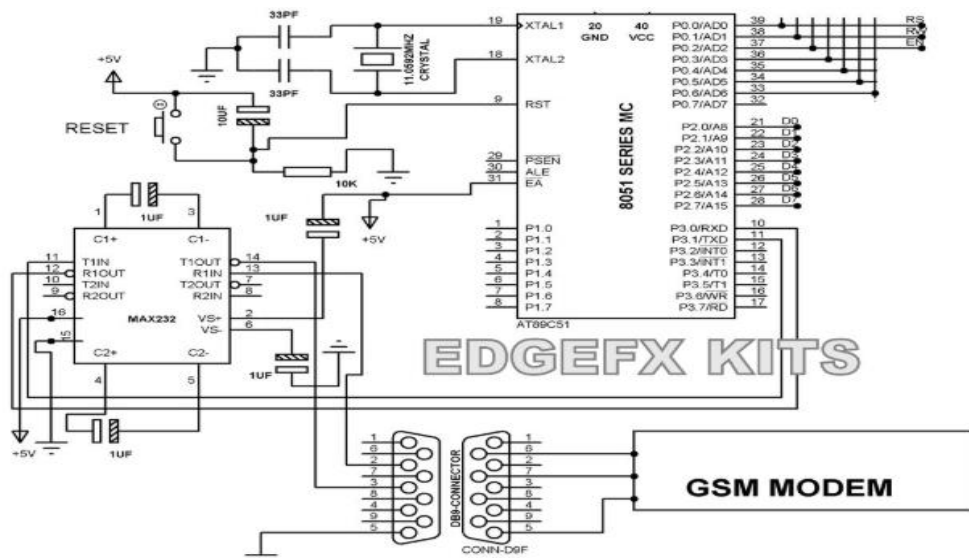

Fig 2: Block diagram of GSM

3.3.2 Working of GPS

To find the location on the earth the whole is divided into some coordinates where the location can be easily captured by a module called GPS module. Here the GPS used is SIM28ML. This GPS module will find the location of the vehicle and the information fetched by the GPS receiver is received through the coordinates and the received data is first send to Arduino and the information is transmitted to the saved contact through GSM module. The frequency is operated in the range of 1575.42 MHz and the output of GPS module is in NMEA format which includes data like location in real time.

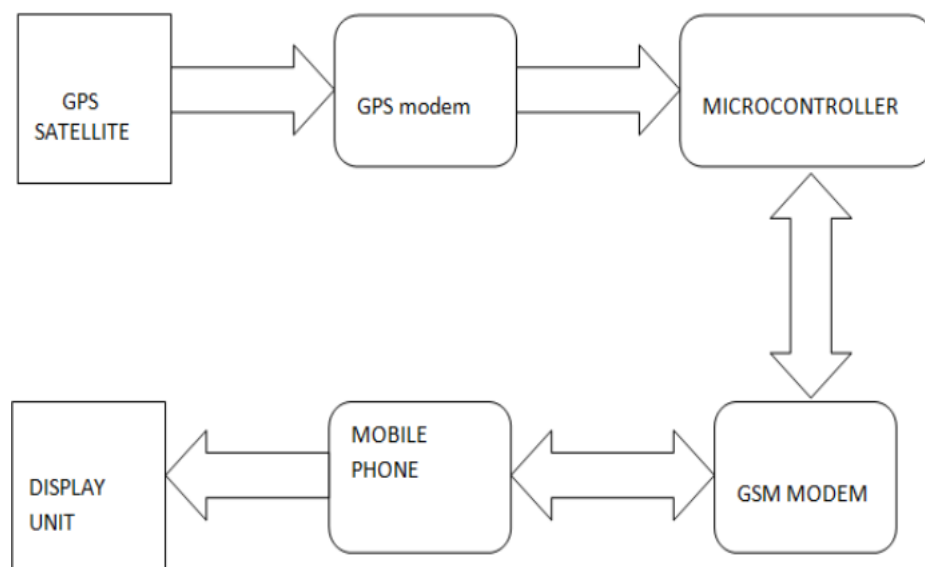

Fig 3: Block diagram of GPS

3.3.3 Working of Arduino

The Arduino UNO is a widely used open-source microcontroller board based on the ATmega328P microcontroller and developed by Arduino.cc. The Arduino is the major control unit to detect or alert when an accident occurs. It collects the data from vibration sensor, GPRS and GSM modules and reflects the output either in display system or through a message. Here vibration sensor plays a major role. This vibration sensor will receive the vibrations of the vehicle which in turn acts as a accident detection module. Arduino gathers the information from all other modules and sends the message to the receiver though GSM module

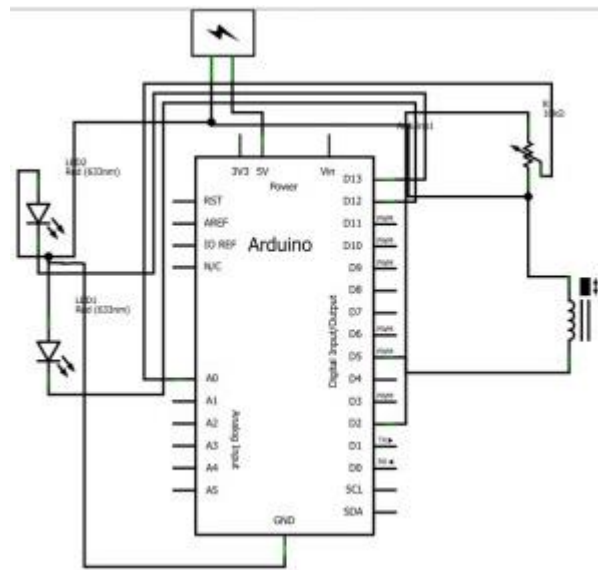

Fig 4: Block diagram of Arduino

3.3.4 Working of Accelerometer

The basic underlying working principle of an accelerometer is such as a dumped mass on a spring. Piezoelectric, piezo resistive and capacitive components are generally used to convert the mechanical motion caused in accelerometer into an electrical signal. Piezoelectric accelerometers are made up of single crystals.

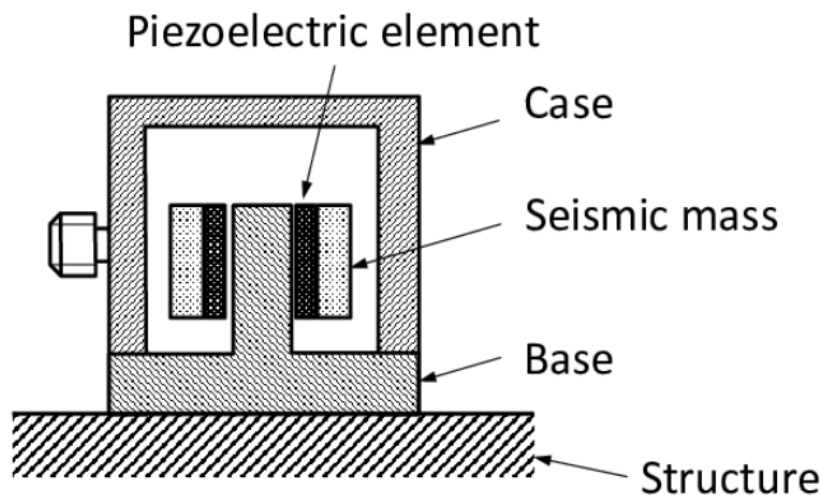

Fig 5: Block diagram of Accelerometer

3.3.5 Working of Gyroscope

A gyroscope is a device designed to have a spinning disc or wheel mounted on a base such that its axis can turn freely in one or more directions in order to maintain its orientation regardless of any movement of the base. However, the orientation changes in response to an external torque and in a different direction.

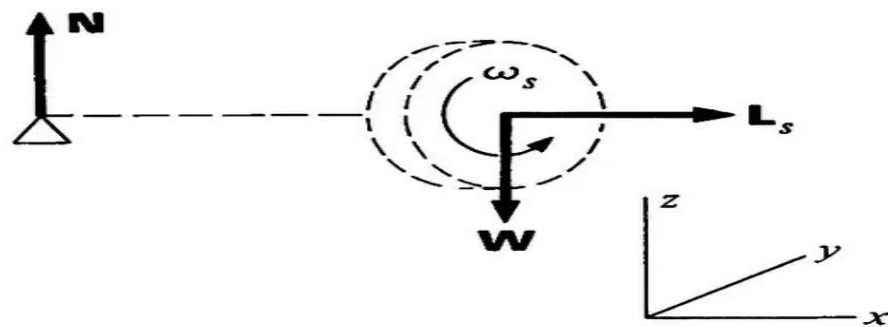

Fig 6: Block diagram of Gyroscope

3.3.6 Working of Vibration Sensor

The vibration sensor is also called a piezoelectric sensor. These sensors are flexible devices which are used for measuring various processes. This sensor uses the piezoelectric effects while measuring the changes within acceleration, pressure, temperature, force otherwise strain by changing to an electrical charge. This sensor is also used for deciding fragrances within the air by immediately measuring capacitance as well as quality.

The working principle of vibration sensor is a sensor which operates based on different optical otherwise mechanical principles for detecting observed system vibrations. The sensitivity of these sensors normally ranges from 10 mV/g to 100 mV/g, and there are lower and higher sensitivities are also accessible. The sensitivity of the sensor can be selected based on the application. So, it is essential to know the

levels of vibration amplitude range to which the sensor will be exposed throughout measurement

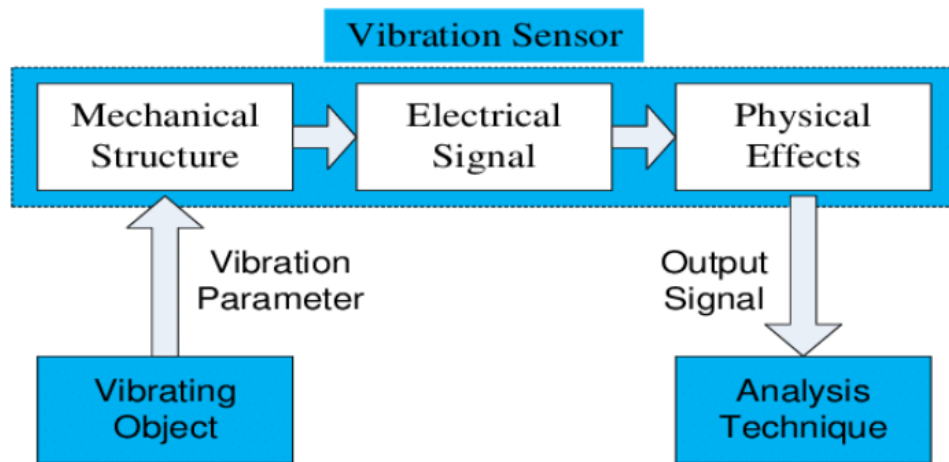

Fig 7: Block diagram of Vibration sensor

3.4 Software Requirements

Arduino is an open-source electronics platform based on easy-to-use hardware and software. Arduino boards are able to read inputs - light on a sensor, a finger on a button, or a Twitter message - and turn it into an output - activating a motor, turning on an LED, publishing something online. You can tell your board what to do by sending a set of instructions to the microcontroller on the board. To do so you use the Arduino programming language (based on Wiring), and the Arduino Software (IDE), based on Processing.

Over the years Arduino has been the brain of thousands of projects, from everyday objects to complex scientific instruments. A worldwide community of makers - students, hobbyists, artists, programmers, and professionals - has gathered around this open-source platform, their contributions have added up to an incredible amount of accessible knowledge that can be of great help to novices and experts alike.

Arduino was born at the Ivrea Interaction Design Institute as an easy tool for fast prototyping, aimed at students without a background in electronics and programming. As soon as it reached a wider community, the Arduino board started changing to adapt to new needs and challenges, differentiating its offer from simple 8-bit boards

to products for IoT applications, wearable, 3D printing, and embedded environments. All Arduino boards are completely open-source, empowering users to build them independently and eventually adapt them to their particular needs. The software, too, is open-source, and it is growing through the contributions of users worldwide.

CHAPTER 4

SYSTEM ANALYSIS AND DESIGN

4.1 System Design:

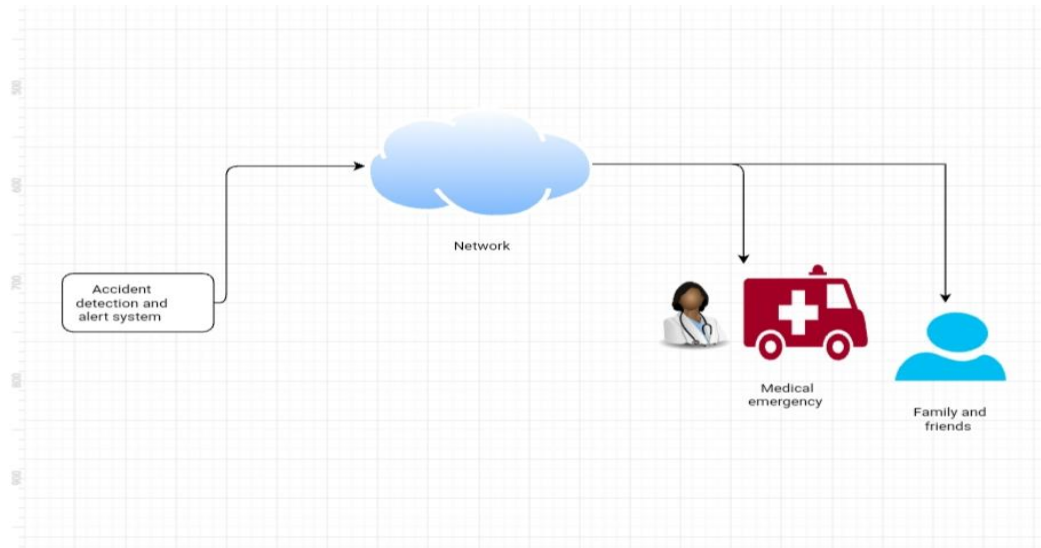

Fig 8: System design

4.2 Flow Chart:

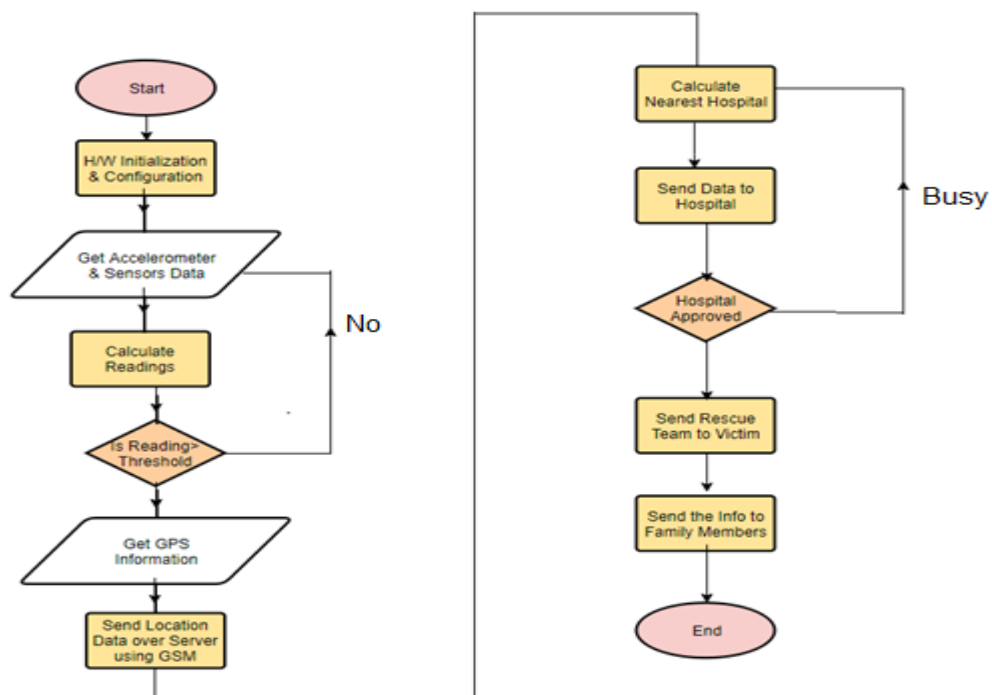

Fig 9: Flowchart

- At start the hardware will be initialised and it takes the reading from hardware every second.
- If the reading overcomes the threshold reading of sensors then Arduino sends the GPS co-ordinates to emergency dial via GPS.
- Emergency dialler checks the coordinates at portal and contacts the nearby hospitals for emergency need and waits for its approval.
- After the hospital approval the rescue team reaches the location of accident and upon confirmation it informs their family members.

4.3 Use case Diagram:

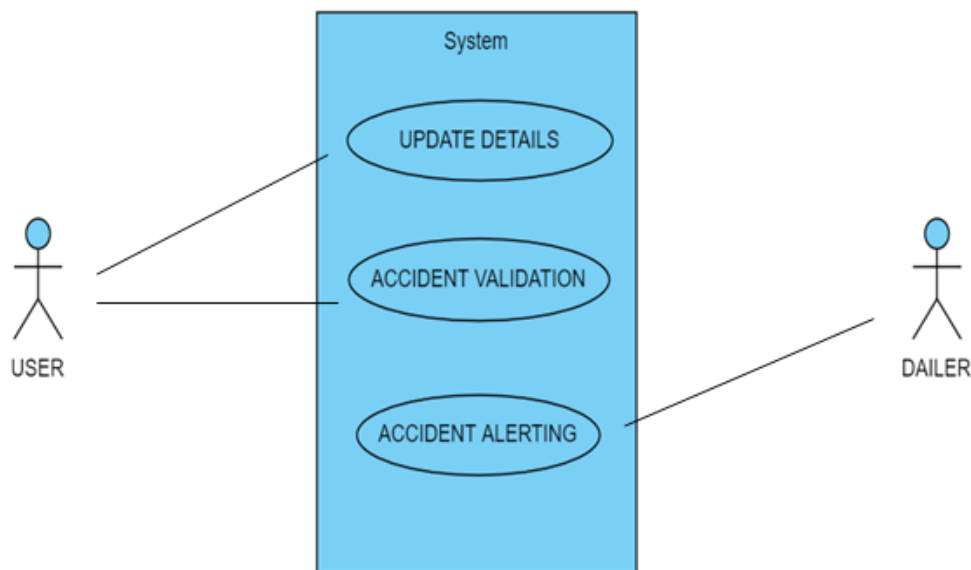

Fig 10: Use case diagram

- The user has the facility to update details of him and emergency contacts.
- The user has the facility to abort the emergency dial to responder by using control switch.
- The dialler/responder is the one who awaits for the accident alert designed from the system.

CHAPTER 5

IMPLEMENTATION

5.1 Proposed Algorithm

Step1: Start

Step2: Set threshold values for sensors

Step3: Calculate Sensor values

If (sensor values < threshold values)

go to step 3

else

go to step 4

Step4: Get GPS co-ordinates

Step5: Send the information to help centre

Step6: Help centre contacts the nearest hospital by GPS co-ordinates

Step7: If (Hospital approves)

go to step 8

else

go to step 6

Step8: Send an ambulance or rescue team to location

Step9: Stop

Arduino Nano is used as controlling unit, communicating between modules for better information transformation at time. Accelerometer can be used for detecting the collision direction from tri-lateral axis movements. Gyroscope can be used for rollover collisions after a threshold of roll and pitch values, the weight and centre of gravity of vehicle plays an important role in rollover. The device also confirms from vibration sensors which detects the collision after a threshold voltage increase. Then a buzzer is provided to abort the false detection of accident to the passenger. Within of limited time of buzzer signal the GPS module collects the coordinates from Google Module.

These co-ordinates nearby hospitals are alerted for emergency rescue call to passenger. The hospital approves the accident by verifying the accident at specified location and confirms the accident. The saved personal members of family are informed regarding the accident through GSM module.

5.2 Code used:

```
#include <math.h>
#include <TinyGPS.h>
#include <SoftwareSerial.h>

const int x_out = A1; /* connect x_out of module to A1 of UNO
board */
const int y_out = A2; /* connect y_out of module to A2 of UNO
board */
int vib_pin=7;
/* connect z_out of module to A3 of UNO board */
TinyGPS gps;
float lat=12.9647771,lon=77.7088037;
SoftwareSerial gpsSerial(3,4);//rx,tx
SoftwareSerial mySerial(9,10);

void setup() {
    // put your setup code here, to run once:
    Serial.begin(9600);
    mySerial.begin(9600);
    gpsSerial.begin(9600);
    pinMode(vib_pin, INPUT);
    delay(1000);
}

void readgsm()
{
    //Begin serial communication with Arduino and Arduino IDE
    (Serial Monitor)
    Serial.begin(9600);

    //Begin serial communication with Arduino and SIM900
    mySerial.begin(9600);
```

```
Serial.println("Initializing...");
delay(1000);

mySerial.println("AT"); //Handshaking with SIM900
updateSerial();
//Serial.println("Hello");
mySerial.println("AT+CMGF=1"); // Configuring TEXT mode
updateSerial();
//Serial.println("Hello");
mySerial.println("AT+CMGS=\"+919030246810\"");//change ZZ with
country code and xxxxxxxxxxxx with phone number to sms
updateSerial();
//Serial.println("Hello");
mySerial.print("http://maps.google.com/maps?q="); //text
content
mySerial.print(lat);
mySerial.print(",");
mySerial.print(lon);
updateSerial();
mySerial.write(26);

return;
}

void updateSerial()
{
  delay(500);
  while (Serial.available())
  {
    mySerial.write(Serial.read());//Forward what Serial received
to Software Serial Port
  }
  while(mySerial.available())
  {
    Serial.write(mySerial.read());//Forward what Software Serial
received to Serial Port
  }
}
```



```
void readgps(){
    while(gpsSerial.available()){ // check for gps data
        if(gps.encode(gpsSerial.read()))// encode gps data
        {
            gps.f_get_position(&lat,&lon); // get latitude and longitude
            // display position
            // lcd.clear();
            // lcd.setCursor(1,0);
            // lcd.print("GPS Signal");
            Serial.print("Position: ");
            Serial.print("Latitude:");
            Serial.print(lat,6);
            Serial.print(";");
            Serial.print("Longitude:");
            Serial.println(lon,6);
            // lcd.setCursor(1,0);
            // lcd.print("LAT:");
            // lcd.setCursor(5,0);
            // lcd.print(lat);
            Serial.print(lat);
            Serial.print(" ");
            // lcd.setCursor(0,1);
            // lcd.print(",LON:");
            // lcd.setCursor(5,1);
            // lcd.print(lon);
        }
    }
    String latitude = String(lat,6);
    String longitude = String(lon,6);
    Serial.println(latitude+" "+longitude);
    delay(1000);
    readgsm();
}
```

```
void loop() {
    // put your main code here, to run repeatedly:
    vib();
}
```

```
    acc();
}

void acc(){
    int x_adc_value, y_adc_value;
    x_adc_value = analogRead(x_out); /* Digital value of voltage
on x_out pin */
    y_adc_value = analogRead(y_out);

    Serial.print("x = ");
    Serial.println(analogRead(x_out));
    Serial.print("y = ");
    Serial.println(analogRead(y_out));

    delay(1000);
    if (((x_adc_value)-(y_adc_value)>=25) || ((y_adc_value)-
(x_adc_value)>=25))
    {

        Serial.println("accident happened");
        Serial.println("$accident happened#");
        delay(1000);
        readgps();
        delay(1000);
        //readGSM();
        delay(10000);
    }
}

void vib()
{
    int val;
    val=digitalRead(vib_pin);
    if(val==0)
    //if(digitalRead(vib_pin)==0)
    {

        Serial.println("$accident occured#");
        delay(1000);
    }
}
```

```
readgps ();  
delay(1000);  
//readGSM();  
delay(10000);  
// lcd.clear();  
}  
}
```

CHAPTER 6

RESULTS AND DISCUSSION

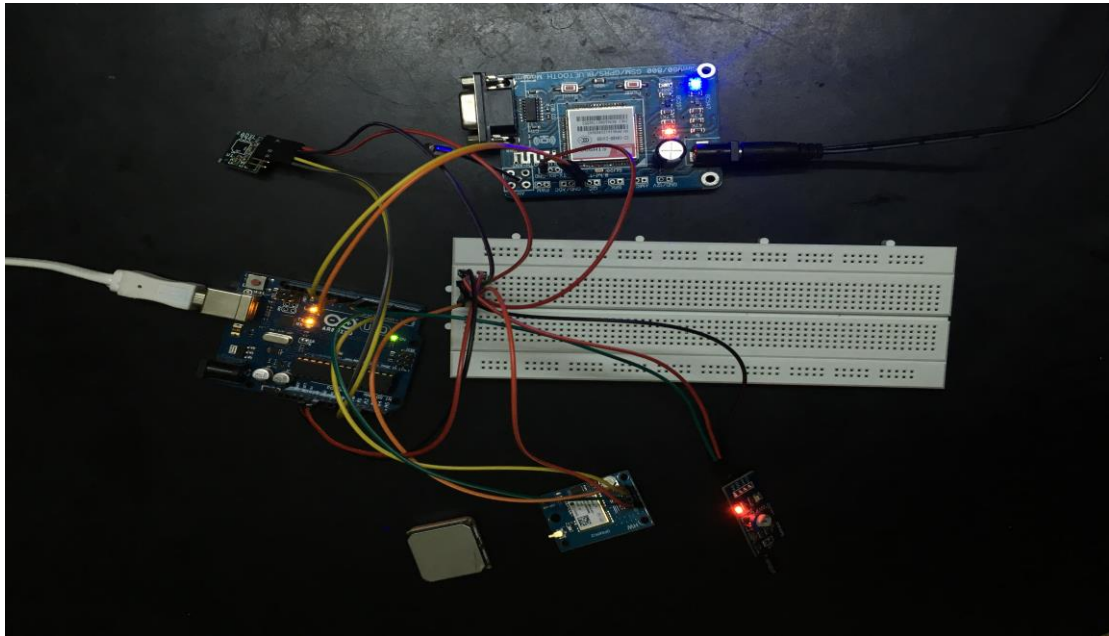

Fig 11: interfacing controller with all other module

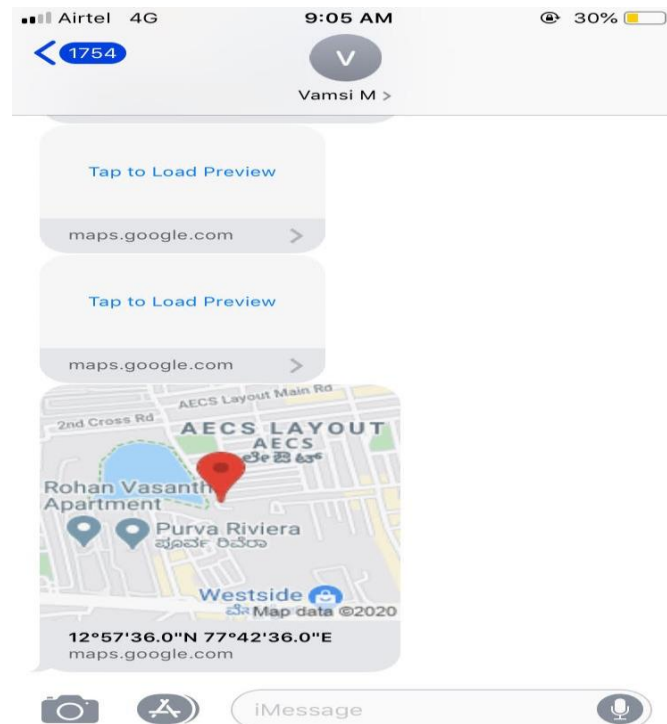

Fig 12: Alert message

CHAPTER 7

TESTING

There are four individual tests that have to be performed before setting up the proposed system.

7.1 Reading data from MPU-6050 module

The Arduino reads data from MPU-6050 gyroscope + accelerometer module; it is based on MEM technology. Both accelerometer and gyroscope is embedded into single chip. This chip uses I2C bus interface which is used for communicating with host interface. It has 8 pins in the chip, In order to check I2C connection between the Arduino and MPU 6050, code should be generated. Wire library's header is included, we define and some variables after this, convert function has to be defined, Setup function which usually checks for serial connection which has to be established.



```
test | Arduino 1.8.12 (Windows Store 1.8.33.0)
File Edit Sketch Tools Help
test
#include <math.h>
#include <TinyGPS.h>
#include <SoftwareSerial.h>
const int x_out = A1; /* connect x_out of module to A1 of UNO board */
const int y_out = A2; /* connect y_out of module to A2 of UNO board */
int vib_pin=7;
/* connect z_out of module to A3 of UNO board */
TinyGPS gps;
float lat=12.9647771,lon=77.7088037;
SoftwareSerial gpsSerial(3,4);//rx,tx
SoftwareSerial mySerial(9,10);

void setup() {
  // put your setup code here, to run once:
  Serial.begin(9600);
  mySerial.begin(9600);
  gpsSerial.begin(9600);
  pinMode(vib_pin,INPUT);
  delay(1000);
}
```

Fig 13: Testing of Arduino

7.2 Location data Reading from GPS module

U-blox Neo-6M GPS module has to be tested to check if it is able to point the location. GPS receivers actually work by figuring out how far they are from a number of satellites. They are pre-programmed to know where the GPS satellites are at any given time. The satellites transmit information about their position and the current time in the form of radio signals towards the Earth. These signals identify the satellites and tell the receiver where they are located. It indicates the position fix, it will blink at various rates depending on what state it is in. No Blinking indicates that it is searching for the satellites. If it blinks every second which indicates that the position is found.

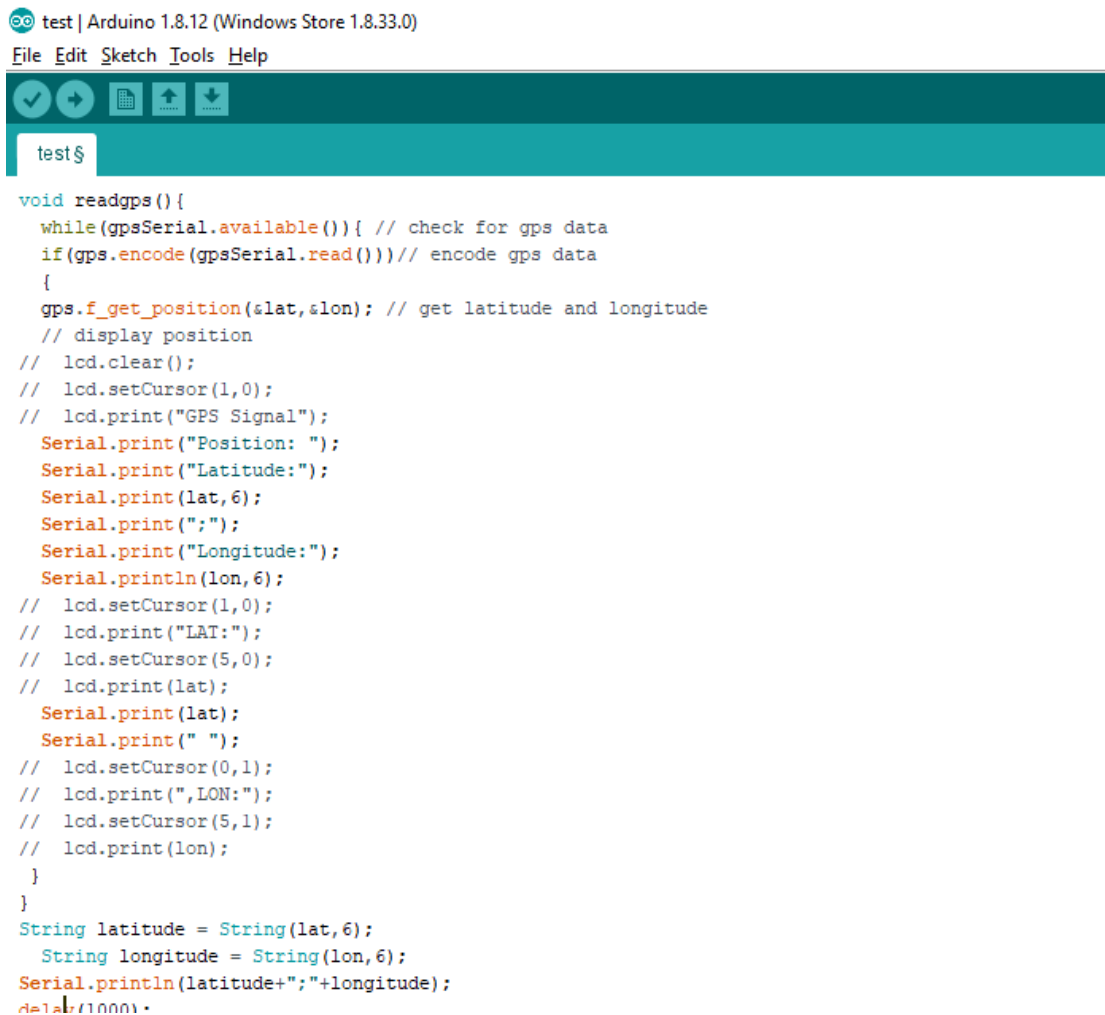

```
test | Arduino 1.8.12 (Windows Store 1.8.33.0)
File Edit Sketch Tools Help
test$
void readgps() {
  while(gpsSerial.available()){ // check for gps data
    if(gps.encode(gpsSerial.read()))// encode gps data
    {
      gps.f_get_position(&lat,&lon); // get latitude and longitude
      // display position
      // lcd.clear();
      // lcd.setCursor(1,0);
      // lcd.print("GPS Signal");
      Serial.print("Position: ");
      Serial.print("Latitude:");
      Serial.print(lat,6);
      Serial.print(";");
      Serial.print("Longitude:");
      Serial.println(lon,6);
      // lcd.setCursor(1,0);
      // lcd.print("LAT:");
      // lcd.setCursor(5,0);
      // lcd.print(lat);
      Serial.print(lat);
      Serial.print(" ");
      // lcd.setCursor(0,1);
      // lcd.print(",LON:");
      // lcd.setCursor(5,1);
      // lcd.print(lon);
    }
  }
  String latitude = String(lat,6);
  String longitude = String(lon,6);
  Serial.println(latitude+" "+longitude);
  delay(1000);
}
```

Fig 14: Testing of GPS module

7.3 Sending Alert message by GSM SIM900A module

We have to make sure that the connection is established between Arduino and GSM. There are two ways of doing it, One is to connect TX pin of GSM to RX pin of Arduino and RX pin of GSM module to TX pin of Arduino. Two is by selecting two PWM enabled pins of Arduino (Pin 9, 10). It uses software serial library of Arduino, when the connection is established the data can be fed directly to GSM.

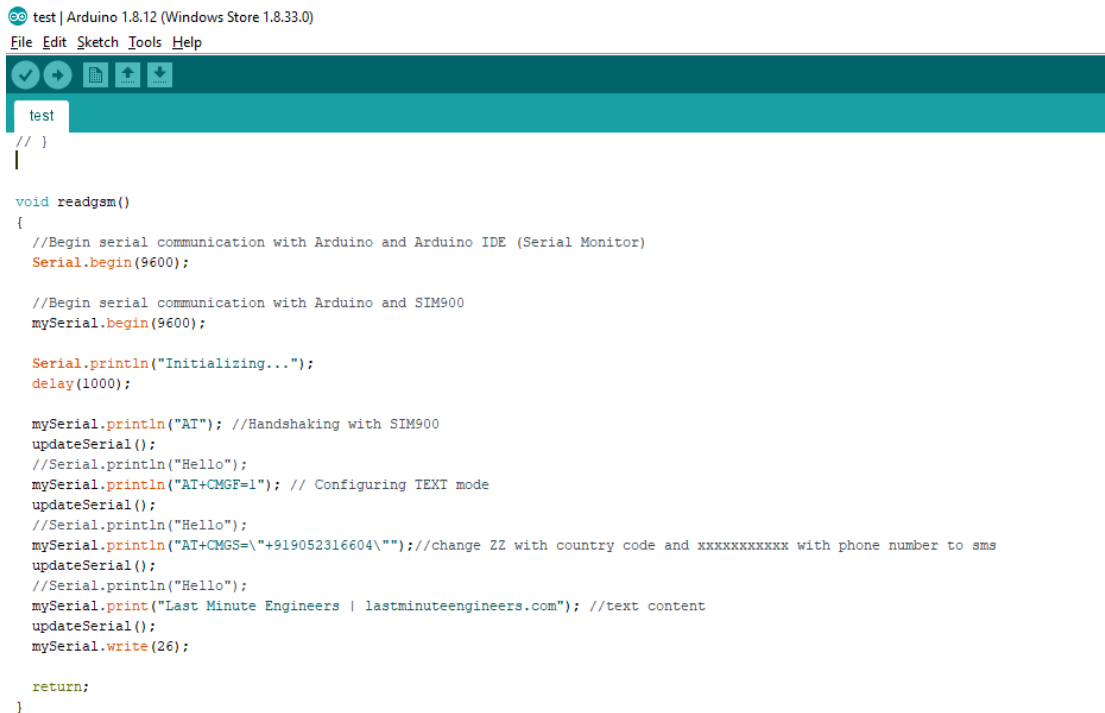

```
test | Arduino 1.8.12 (Windows Store 1.8.33.0)
File Edit Sketch Tools Help
test
// }
|

void readgsm()
{
  //Begin serial communication with Arduino and Arduino IDE (Serial Monitor)
  Serial.begin(9600);

  //Begin serial communication with Arduino and SIM900
  mySerial.begin(9600);

  Serial.println("Initializing...");
  delay(1000);

  mySerial.println("AT"); //Handshaking with SIM900
  updateSerial();
  //Serial.println("Hello");
  mySerial.println("AT+CMGF=1"); // Configuring TEXT mode
  updateSerial();
  //Serial.println("Hello");
  mySerial.println("AT+CMGS="+919052316604+"\"); //change ZZ with country code and xxxxxxxxxxxx with phone number to sms
  updateSerial();
  //Serial.println("Hello");
  mySerial.print("Last Minute Engineers | lastminuteengineers.com"); //text content
  updateSerial();
  mySerial.write(26);

  return;
}
```

Fig 15: Testing of GSM

7.4 Displaying on LCD

Interfacing between LCD and Arduino is also tested. We should study the schematic carefully. Next is to place your LCD on the bread board. Make sure that the connection is done according to the circuit diagram. Instead of the potentiometer, you can use a 1k resistor and connect Pin 3 of LCD to Vcc via the resistor. Carefully check whether all the connections are tight and correct. Power up your Arduino via USB and check whether the LCD lights up. If yes, proceed.

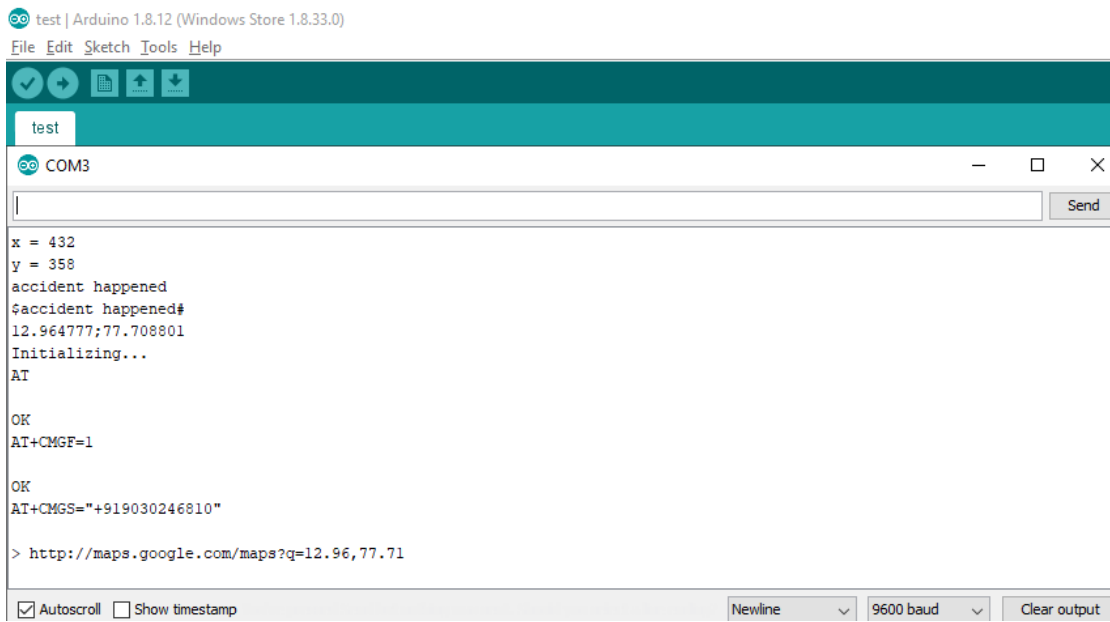

Fig 16: Testing of accident detection

CHAPTER 8

CONCLUSION AND FUTURE SCOPE

8.1 Conclusion

A system to detect an event of accident has been developed. The proposed system deals with accident alerting and detection. It reads the exact latitude and longitude of the vehicle involved in the accident and sends this information to nearest emergency service provider. Arduino helps in transferring the message to different devices in the system. Accelerometer monitors the accident happening direction and gyroscope is used to determine rollover of the vehicle. The information is transferred to the registered number through GSM module. Using GPS, the location can be sent through tracking system to cover the geographical coordinates over the area.

8.2 Contribution

The proposed system contributes to decreasing death rate caused by accidents. It detects the accidents occurred with the help of proposed methodology, It also fetches the location of the accident using GPS module and sends the alert message using GSM module to the medical emergency which can get to the location of accident in time which can also save lives of people. By this feature the death rate caused by accidents can be reduced.

8.3 Future Scope

The future scope of this system can have some improvisation using a wireless webcam can be added in this for capturing the images which will help in providing driver`s assistance. This can also be bettered by locking all the brakes automatically in case of accident. Mostly in accidents, it becomes serious as the drivers lose control and fails to stop the vehicle. In such cases, the vibration sensor will be triggered because of the vibrations received and also processed by the processor. The processor has to be linked to the devices which can lock the brakes when triggered. With this improvement, we can stop the vehicle and can weaken the impact of the accident. This system can also be utilized in fleet management, food services, traffic violation cases, rental vehicle services etc.

REFERENCES

- [1] T Kalyani, S Monika, B Naresh, Mahendra Vucha, Accident Detection and Alert System, IJITEE, March 2019(Base paper).
- [2] Parag Parmar, Ashok M.Sapkal, Real time detection and reporting of vehicle collision, IEEE,2017.
- [3] Md. Syedul Amin, Jubayer Jalil, M.B.I.Reaz, Accident Detection and Reporting System using GPS,GPRS and GSM Technology, IEEE,2012.
- [4] Gowshika B, MadhuMitha, G,Jayashree,Vehicle accident detection system using GPS, GSM modem, IRJET,2019.
- [5] Sayanee Nanda, Harshada Joshi, Smitha Khairnar, An IOT Based Smart System for Accident Prevention and Detection,IEEE,2018.
- [6] Norsuzila Yaacob, Ainnur Eiza Azhar, Azita Laily Yusofl, Suzi Seroja Sarnin, Darmawaty Mohd Ali and Ammar Anuar, Real Time Wireless Accident Tracker using Mobile Phone,IEEE,2017.
- [7] S.Sonika, Dr.K.Sathyasekhar, S.Jaishree, Intelligent accident identification system using GPS, GSM modem,DARCCE,2014.
- [8] Dhruvesh H.Patel, Parth Sadatiya, Dhruvbhai K. Patel, Prasann Barot, IoT based Obligatory usage of Safety Equipment for Alcohol and Accident Detection,IEEE,2019.
- [9] Ajith Kumar.A, Jaganivasan.V, Sathish.T, Mohanram.S,Accident detection and alert system using GPS&GSM,IJOPAAM,2018.
- [10] Shadman Sakib, Mohammad Sayem Bin Abdullah,GPS-GSM based Inland Vessel Tracking System for Automatic Emergency Detection and Position Notification,IEEE,2016.

