

USN : 

CMR Institute of Technology, Bangalore
DEPARTMENT OF ELECTRICAL & ELECTRONICS ENGINEERING
I - INTERNAL ASSESSMENT

Semester: 8-CBCS 2017

Subject: OPERATION AND MAINTENANCE OF SOLAR ELECTRIC SYSTEMS (17EE832)

Faculty: Ms Reshma P Eldho

Date: 22 May 2021

Time: 01:00 PM - 02:30 PM

Max Marks: 50

Answer any 5 question(s)

Q.No		Marks	CO	PO	BT/CL
1	a) Explain the effect of the Earth's atmosphere on solar radiation with neat diagram. b) Explain the terms Peak sun hours (PSH) and Irradiance and briefly explain the importance of the terms in solar power generation.	10	CO1	PO1	L1
2	Explain the various mainstream and emerging technologies in the solar cells?	10	CO1	PO1	L2
3	a)What are the various precautions are required to purchase solar modules for house hold requirements. b) Explain the various Standards for the PV Solar Modules. What is the importance of Specification Sheet mounted on the PV Solar Panels?	10	CO1	PO1	L3
4	Evaluate the Photovoltaic array performance with change in (i) Temperature, (ii) Irradiance and (iii)Shading conditions with graph?	10	CO1	PO1	L1
5	With a neat sketch explain the functioning of (i) String inverters and (ii) Multi-string inverter (iii) Central inverter (v) Modular inverters.	10	CO2	PO1	L2
6	Explain a) the Roof mounting systems b) Pitched roof mounting systems for PV installations	10	CO2	PO1	L2

Example

If sunlight is received at an irradiance of 1000W/m^2 for 2 hours, 600W/m^2 for 1.5 hours and 200W/m^2 for 1 hour, the total radiation received that day is 3.1PSH:

$$1000\text{W/m}^2 \times 2 \text{ hours} + 600\text{W/m}^2 \times 1.5 \text{ hours} + 200\text{W/m}^2 \times 1 \text{ hour} = 3100\text{W/m}^2/\text{day}$$

$$3100\text{W/m}^2/\text{day} \div 1000\text{W/m}^2/\text{day} = 3.1\text{PSH}$$

The effect of the Earth's atmosphere on solar radiation

The Earth's atmosphere reflects a large amount of the radiation received from the sun – without this protection life could not be sustained on the planet. When solar radiation arrives at the top of the Earth's atmosphere it has a peak irradiance value of 1367W/m^2 (this is known as the solar constant). By the time solar radiation reaches the Earth's surface it has a peak irradiance value of approximately 1000W/m^2 . The difference between the solar constant and the peak irradiance value at the Earth's surface is due to the Earth's albedo – the amount of solar energy reflected from a surface on the Earth at that specific location. Light is reflected from Earth in a variety of ways:

- Radiation is reflected off the atmosphere back into space.
- Radiation is reflected off clouds in the stratosphere.
- The Earth's surface itself reflects sunlight.

The average portion of sunlight reflected from the Earth (the Earth's albedo) is 30 per cent. Polar regions have very high albedo as the ice and snow reflect most sunlight, while ocean areas have a low albedo because dark seawater absorbs a lot of sunlight.

Box 2.3 Key terminology

Direct radiation: Solar radiation that passes directly to the Earth's surface.

Diffuse radiation: Solar radiation that is scattered or absorbed by clouds and gases within the atmosphere and then re-emitted – diffuse radiation is less powerful than direct radiation.

Air mass: The distance that radiation must travel through the atmosphere to reach a point on the surface. This value varies throughout the day for a location.

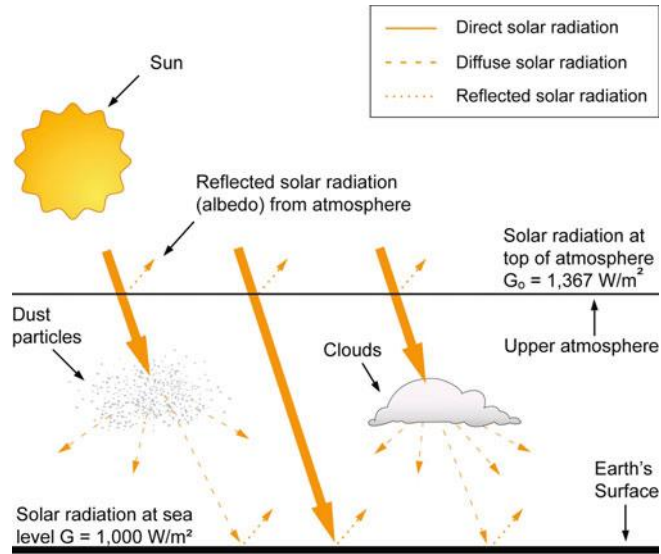

Figure 2.7 Solar radiation comprises direct and diffuse radiation

Source: Global Sustainable Energy Solutions

Irradiance is a combination of direct and diffuse radiation and will depend on the albedo (reflected solar radiation) of that particular location.

That proportion of solar radiation which is scattered, absorbed or re-emitted in the atmosphere is diffuse radiation. Understandably on a sunny day, this scattered diffuse radiation will contribute only to 10 per cent of visible light, but on a cloudy day there will be much more scattering of the solar radiation reaching the Earth's surface which means the amount of diffuse radiation will be much greater. Air mass will also affect the irradiance at a location. The

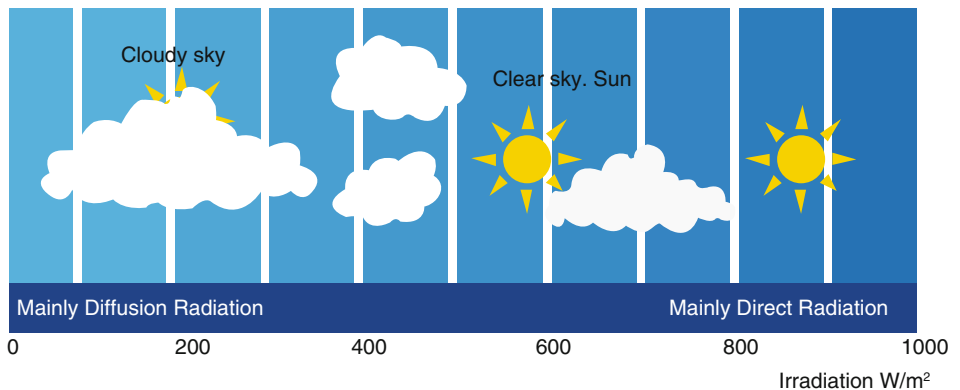

Figure 2.8 The more clouds in the sky the less irradiation there will be and the larger the diffuse radiation component

Source: Deutsche Gesellschaft für Sonnenenergie e.V. (DGS)

greater the air mass, the higher the chance of light being reflected or scattered, meaning there will be less solar radiation reaching the Earth's surface.

Air mass of 1.5 is the standard condition at which solar modules are rated. Air mass zero refers to air mass in space; air mass one corresponds to conditions when the sun is directly overhead. Regions outside the tropics will never experience air mass one, as the sun is never directly overhead.

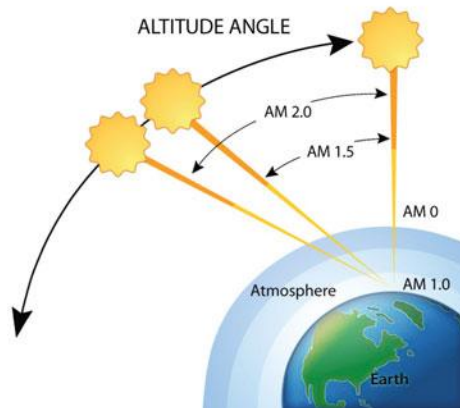

Figure 2.9 From the surface of the Earth, air mass is directly related to the altitude of the sun

Source: Global Sustainable Energy Solutions

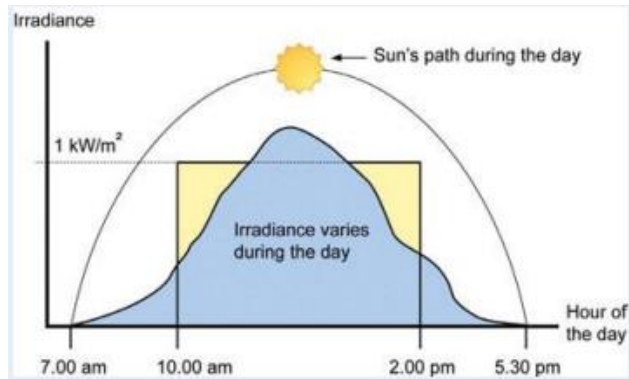

Figure 2.10 At sunset the sun is low in the sky and therefore air mass is very high. Light is scattered so much that the white light is separated into its different colours. Most of the colours scatter so that they are not visible but red light scatters the least, which is why we see red sunsets on cloudy days. Blue light is scattered the most, which is why the sky is blue when sunlight passes through the least amount of atmosphere (during the day)

Source: Global Sustainable Energy Solutions

1.b) PSH:

Peak sun hours (PSH): Daily irradiation is commonly referred to as daily PSH (or full sun hours). The number of PSH for the day is the number of hours for which power at the rate of 1 kW/m^2 would give an equivalent amount of energy to the total energy for that day. The terms peak sunlight hours and peak sunshine hours may also be used.



Peak sun hours are very useful in system yield calculations. One PSH represents 1 hour of radiation at 1 kW/m^2 . Because the sun does not shine consistently all day the number of peak sun hours will always be less than the number of hours in a day.

Knowing the PSH of your location is very important when installing a solar PV system. This would allow you to estimate the energy the PV system can produce maximally. The higher the PSH, the greater the energy produced from a solar PV system.

Mainstream technologies



1. Monocrystalline silicon



2. Polycrystalline silicon



3. Thin film solar cells

Monocrystalline silicon

- These solar cells are produced from a single silicon seed crystal placed in a crucible of molten silicon and drawn out slowly while rotating.
- Monocrystalline solar cells are typically produced from pseudo-square silicon wafer substrates cut from column ingots grown by the Czochralski (CZ) process.
- In this manner it is possible to produce a larger pure crystalline silicon ingot, which is then sliced into thinner wafers.
- Generally the most expensive, although the higher initial cost may be justified by their increased power output
- Commercially available solar cells are 22.5 percent efficient and finished modules with efficiencies of 19 per cent.

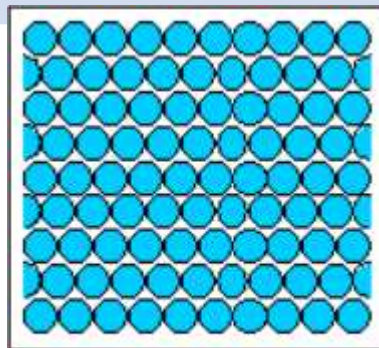

Figure 3.2 A single-crystal silicon ingot is drawn from the molten silicon

Source: Silfex

Main difference is in there internal lattice structure

Mono-crystalline Silicon	Poly-crystalline Silicon
Made from Single silicon ingot	Made from multi-crystal ingot randomly oriented (Manufactures melt many fragments of silicon together to make wafers of panels)
I has higher photoelectric conductivity	Lesser conductivity
Good power-to-size ratio: efficiency typically within the range of 135-170 Watts per m ²	120-150 Watts per m ²



Single crystal

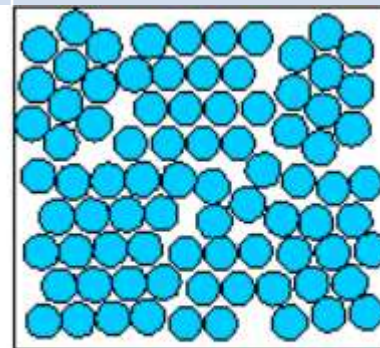

Polycrystal

Multi-crystalline/polycrystalline silicon

- Multi-crystalline or polycrystalline silicon solar cells are manufactured by block casting molten silicon.
- They are not made from a single crystal ingot but rather from one composed of many small crystals, which grow in random orientations as the molten material solidifies.
- This produces lower efficiencies than monocrystalline cells.
- It is still a very popular technique
- it is easier and less expensive.





Mono

To make cells for monocrystalline panels, silicon is formed into bars and cut into wafers.

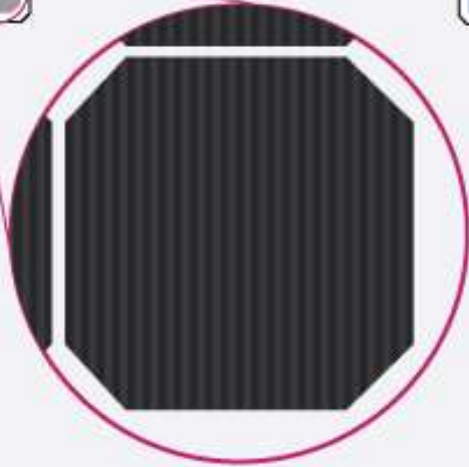

Poly

To make cells for polycrystalline panels, fragments of silicon are melted together to form the wafers.

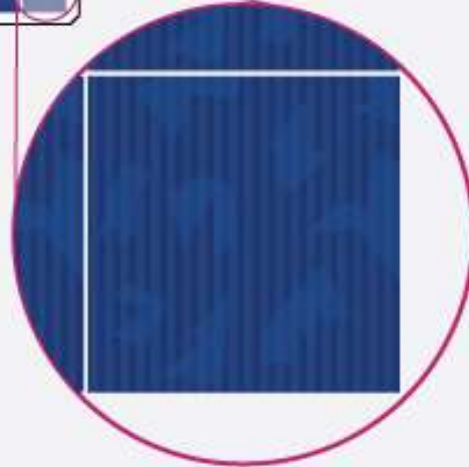

Thin film solar cells/Amorphous silicon cells

- Made by depositing one or more thin layers of [thin film](#) of [photovoltaic](#) material on a substrate, such as glass, plastic or metal.
- Thin film solar cells are made from materials suitable for deposition over large areas.
- The most common materials are made out of cadmium telluride (CdTe) and copper indium gallium diselenide (CIS or CIGS).
- They are made using the chemical vapour deposition (CVD) process, where the material is deposited onto large area materials,
- e.g. coated glass, flexible plastic or stainless steel sheet.



- Film thickness varies from a few nanometers ([nm](#)) to tens of micrometers
- They are less expensive & low cost to manufacture than crystalline solar cells.
- This allows thin film cells to be flexible, and lower in weight.
- It is used in [building integrated photovoltaics](#) and as semi-[transparent](#), photovoltaic glazing material that can be [laminated](#) onto windows.



Figure 3.5 Amorphous silicon modules are easily distinguished from crystalline modules by their dark and uniform colour but they also look like non-silicone thin film modules

Emerging technologies

- Besides well-established mainstream technologies many new technologies are emerging. They are
 1. Dye-sensitized solar cells
 2. Sliver cells
 3. Heterojunction with intrinsic thin layer (HIT) photovoltaic cells
 4. III-V Semiconductors
 5. Solar concentrators

Dye-sensitized solar cells

- Dye solar cells are still technologically immature.
- Operate very differently from other solar cells and do not use silicon.
- Dye solar cells use titanium dioxide and coloured dyes;
- Manufactured at a much lower cost than other solar cells and work better in low light.
- Transparent and Can be produced in many different colours, making them ideal for architectural applications as windows.



- Dye solar cells also have potential in military applications as they can be made in camouflage patterns.
- Highest Efficiency obtained :12 percent.
- 7% efficiency in Production.
- Works at Low artificial light



Sliver cells

- Developed at the Australian National University and are very thin mono-crystalline silicon solar cells.
- They are unique as silicon cells because they are bifacial
- Can be made transparent
- Cell efficiencies: 19% and module efficiencies: 13.85%



- The technology is in its early stages of commercialization
- This technology has high potential for applications in building-integrated photovoltaics



Heterojunction with intrinsic thin layer (HIT) photovoltaic cells

- HIT modules use both crystalline silicon solar cells and amorphous silicon thin film technology
- It combine two different technologies into one cell: a crystalline silicon cell sandwiched between two layers of amorphous “thin film” silicon.
- Module efficiencies of 17 % and cell efficiencies of 22%.
- Thinner solar cell wafers due to the low-temperature of production processes, which is around 200°C

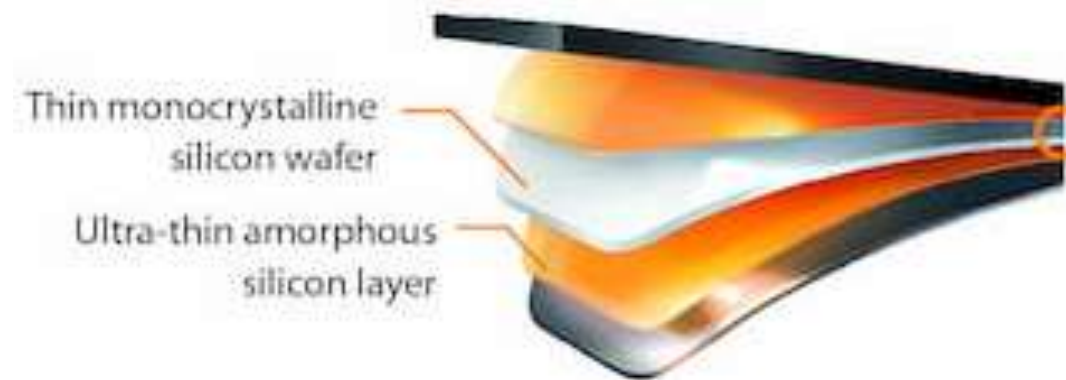

Multi junction III-V Semiconductors

- III-V or extrinsic semiconductor solar cells combine element from group III and an element from group V
- This gives us **12** possible combinations; the most important ones are probably **GaAs**, **InP** **GaP** and **GaN**.

Group III	Group V
B	N
Al	P
Ga	As
In	Sb

Multi junction III-V Semiconductors

- Have many layers of solar cells, which will collect different colours of visible light.
- They also frequently use advanced solar concentrator technology to maximize incoming solar radiation.
- Highest recorded efficiency of 41.6% using concentrated sunlight(Fresnel lenses) fabricated by Spectrolab Inc in the US.
- Using concentrating optics allows individual cells to be quite small—at times, as small as the size of the tip of a pencil.

- Extrinsic semiconductor multi-junction solar cells are the most efficient and most expensive technology on the market.
- Due to their high cost, III-V semiconductor cells are normally used for space applications such as satellites or other big-budget, high-performance, solar powered devices such as solar planes and solar racing cars

Solar concentrators

- Solar concentrators are used to **increase the intensity of light hitting the cell**
- Common type is **lense or reflective troughs** used to focus light.
- It increases the power output so that the system requires fewer solar cells
- Many of these cells require a **cooling system** to perform well, as cell temperatures can get very high.
- Challenges : It should be sturdy and reliable enough to survive decades in solar installations, when keeping in harsh conditions such as desert, and to keep costs as low as possible

3a.

- PV modules purchased from reputable manufacturers should come with specification sheets (also known as data sheets). A data sheet includes important technical information required to design and install a PV array. It may also be useful for a consumer to look at the data sheet when comparing different modules as it provides basic information about efficiency, rated power and physical size.
- PV modules are typically supplied with three levels of product warranty:
 - 1-, 2- or 3-year warranty on the physical manufacture of the module itself, i.e. the frame, encapsulant, glass, module junction box etc.;
 - 10–12 year warranty that the module will produce 90 per cent of its rated output;
 - 20–25 year warranty that the module will produce 80 per cent of its rated output.
- If any of these conditions are not met, the question of a warranty claim will depend on the manufacturer's published warranty and/or the commercial laws of the country where the module was purchased. For example, if someone buys a module from overseas and imports it for sale or their own use, then it is assumed that they understand that they have to send the module back to where they purchased it to claim warranty.
- All manufacturers' data sheets are specific to their products only, and when accessing any solar module specifications (either in soft or hard copy) the manufacturer should be contacted to confirm that their published material is current.

3B.

Standards:

- The PV industry is growing rapidly, resulting in many new manufacturers producing PV modules. It is important that only quality modules are installed and standards do exist. The most common standards applicable to PV modules are:
- IEC 61215 Crystalline silicon terrestrial photovoltaic (PV) modules – Design qualification and type approval.
- IEC 61646 Crystalline thin-film terrestrial photovoltaic (PV) modules – Design qualification and type approval.
- IEC 61730 Photovoltaic (PV) module safety qualification – Requirements for construction and requirements for testing.
- These standards originate from the International Electro-technical Commission. In many countries a PV module must evidence compliance with either IEC 61215 or IEC 61646 (depending on whether it is thin film or crystalline silicon technology) and IEC 61730

Photovoltaic array performance

- The performance of a PV array is affected by a variety of factors: **Temperature, Irradiance and Shading.**

1. Irradiance

- The amount of solar radiation (sunlight) hitting the cell will largely determine its power output.
- The output of a PV array can be estimated using performance data provided by the manufacturer on the data sheet.
- This output has been determined by the manufacturer using standard test conditions.
- Using this information and local solar insolation data , it is possible to estimate the output of an array.

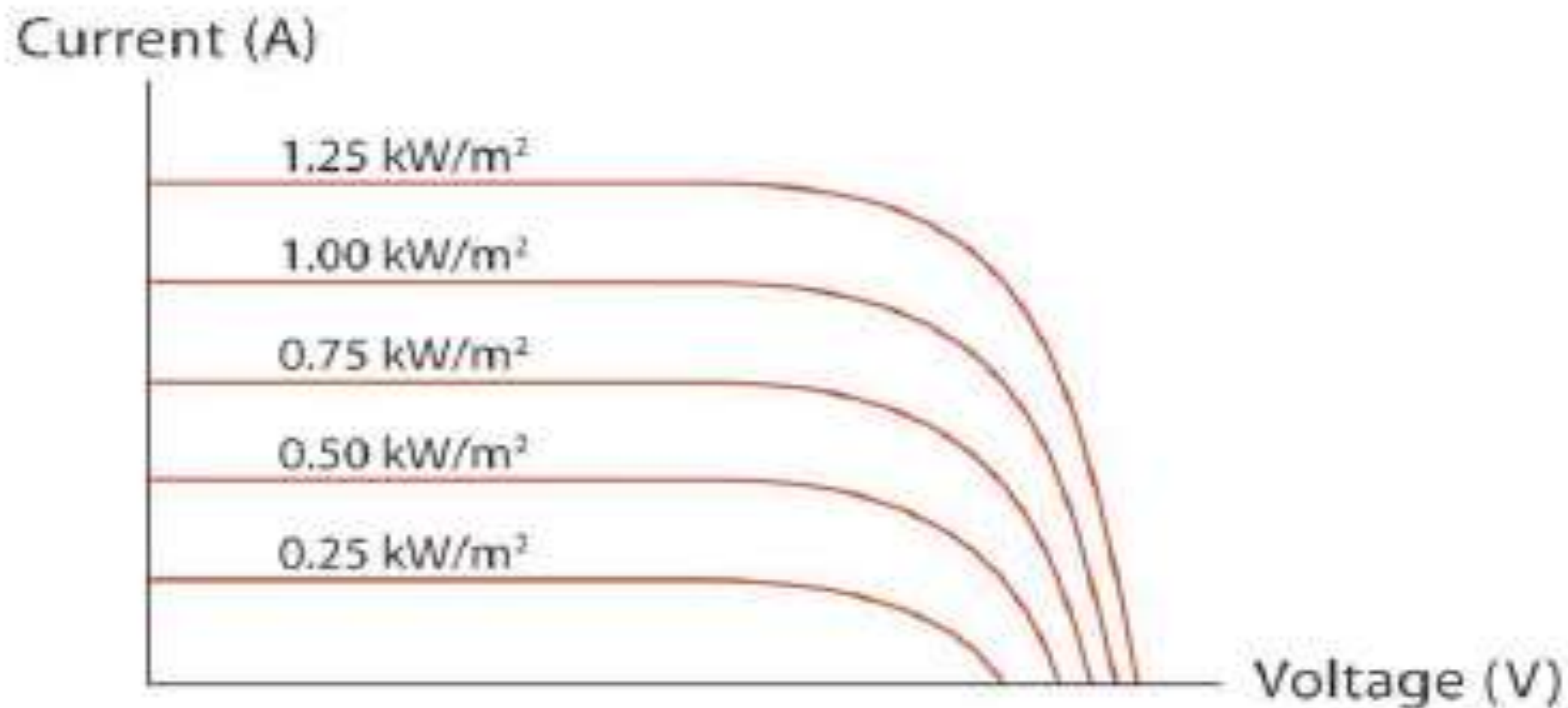

Figure 4.17 The I-V curves for a cell operating at different irradiance values show the increase in power output with irradiance

Source: Global Sustainable Energy Solutions

2. Temperature

- The solar radiation hitting the modules also heats up the modules.
- PV module temperature $\leq 70^{\circ}\text{C}$ on a sunny day
- As temperature increases, the open-circuit voltage decreases rapidly while the short-circuit current increases slowly.
- Power reduces.

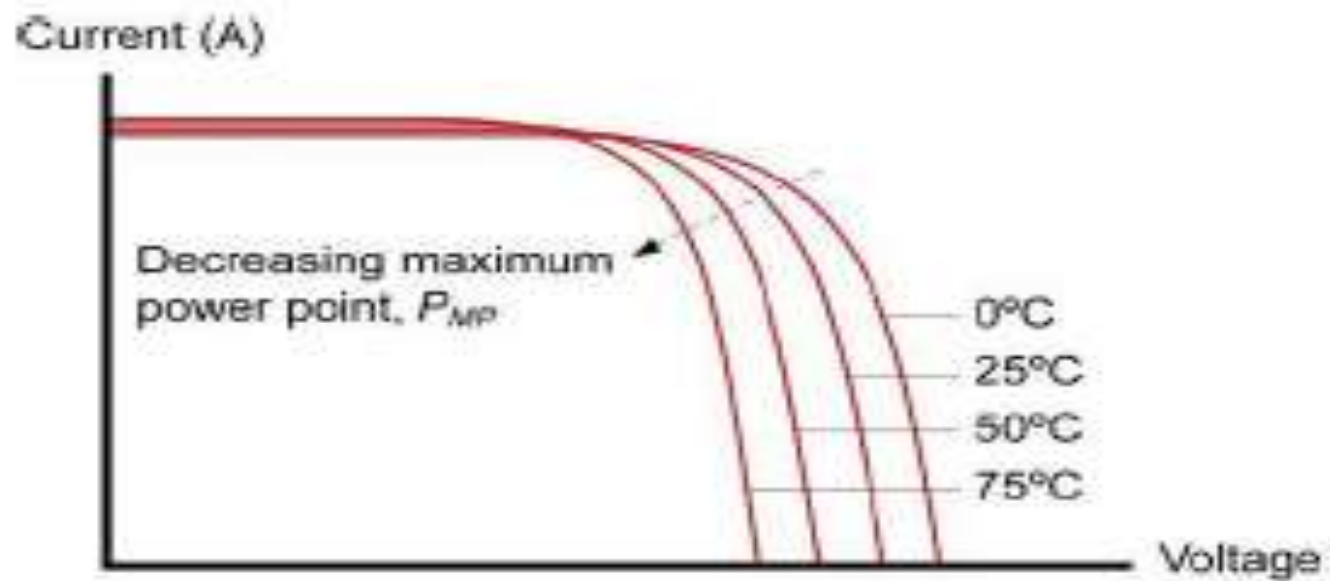
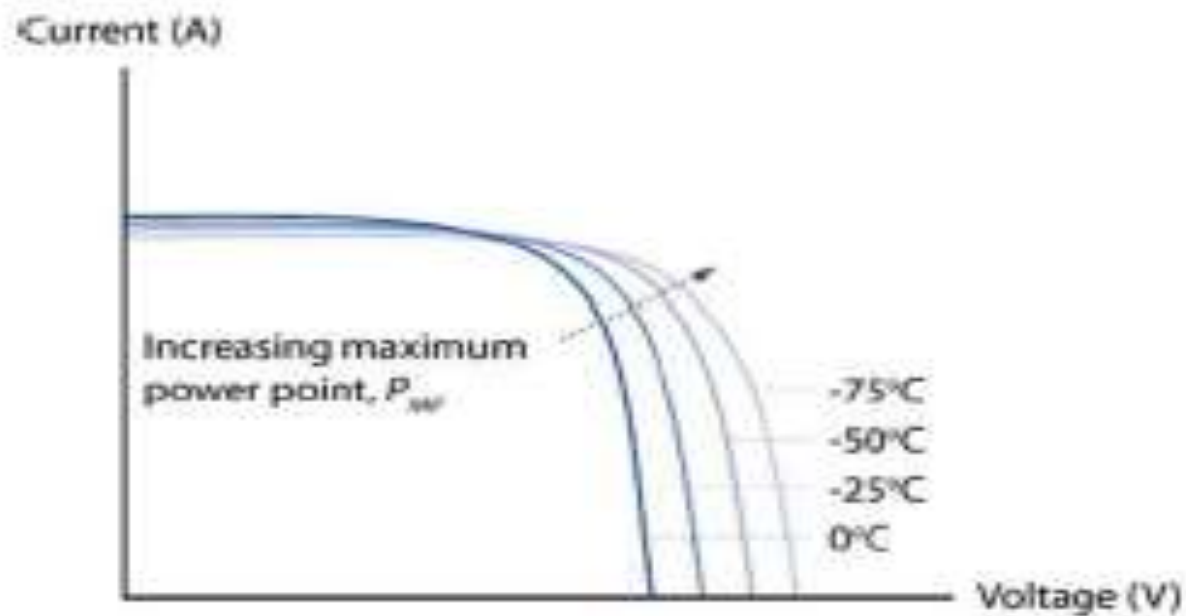

Figure 4.20 PV modules perform well in cold and sunny areas. They are often used as a power source in Antarctica during the summer. However, because there is so little light in winter, diesel generators are typically used as back-up.



- Cold temperatures can increase the power output due to the voltage increase.
- The maximum voltage threshold of the system needs to be accurately calculated to ensure that this voltage cannot exceed the inverter's ratings.
- One contributing factor is when an array is installed flush to a roof surface – meaning that there is limited air flow across the back of the modules to moderate the module temperature.



- Some cases have the roof itself giving off heat, particularly a tin roof, and the module will retain heat on the underside, so forced ventilation across the roof surface and behind the modules is often necessary.
- If the installation cannot include both methods of ventilation, the output of the array will have to be derated to reflect negative aspects of the installation



3. Shading

- PV cells require sunlight in order to produce electricity.
- If a cell receives no sunlight due to shading it will not produce any power
- Even a small area of cell shading can result in a large reduction in power output.



Figure 4.22 Even this small shadow can reduce the amount of electricity a module produces – a small shaded area can, under certain circumstances reduce module output by 80–90 per cent as well as affecting the rest of the array



Figure 4.21 Vegetation, chimneys, buildings, dirt and snow can all shade a PV module

Source: Global Sustainable Energy Solutions

- Cells in modules are normally connected in series, so when one or several cells are shaded, the current output of the module will be reduced.
- If the module is part of an array, then the current output of the array will also be reduced.
- This will also occur if a cell is damaged and unable to produce power.



Figure 4.22 Even this small shadow can reduce the amount of electricity a module produces – a small shaded area can, under certain circumstances reduce module output by 80–90 per cent as well as affecting the rest of the array



Figure 4.21 Vegetation, chimneys, buildings, dirt and snow can all shade a PV module

Source: Global Sustainable Energy Solutions

Problems due to shading

- Shading of the array can lead to irreversible damage.
- **Hot spot heating:** A cell is shaded such that its power output is reduced and most of the current being produced by the other (unshaded) cells is forced through that one cell causing it to heat up.
- This often leads to cell damage (cracking) and can also damage the glass encapsulation.

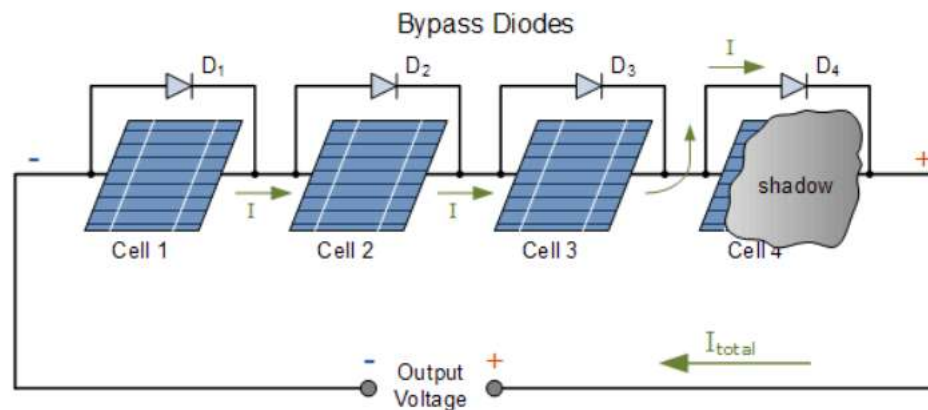

Figure 4.23 The discoloured cell in this array was caused by hot spot heating

Source: Global Sustainable Energy Solutions

Hot spotting can be prevented by

- Diodes can be used to mitigate temporary shading (i.e. leaves that may have fallen on the array).
- When a cell is shaded or damaged, a diode can be used to give current another path to follow.
- It will skip the damaged or shaded cell completely and have minimum impact on the power output of the array.
- This kind of diode is referred to as a bypass diode and manufacturers typically install one, two or three bypass diodes per module



Mainstream inverter technologies

1. String inverters
2. Multi-string inverter
3. Central inverter
4. Modular inverters

String inverters

- String inverters are used in small systems ranging from 1kWp to 11kWp.
- String inverters will all have one maximum power point tracker (MPPT) and the DC input voltages could vary from extra low voltage (ELV) right up 1000 volts DC (low voltage, LV).
- String inverters can be connected in a variety of ways as shown in Figures

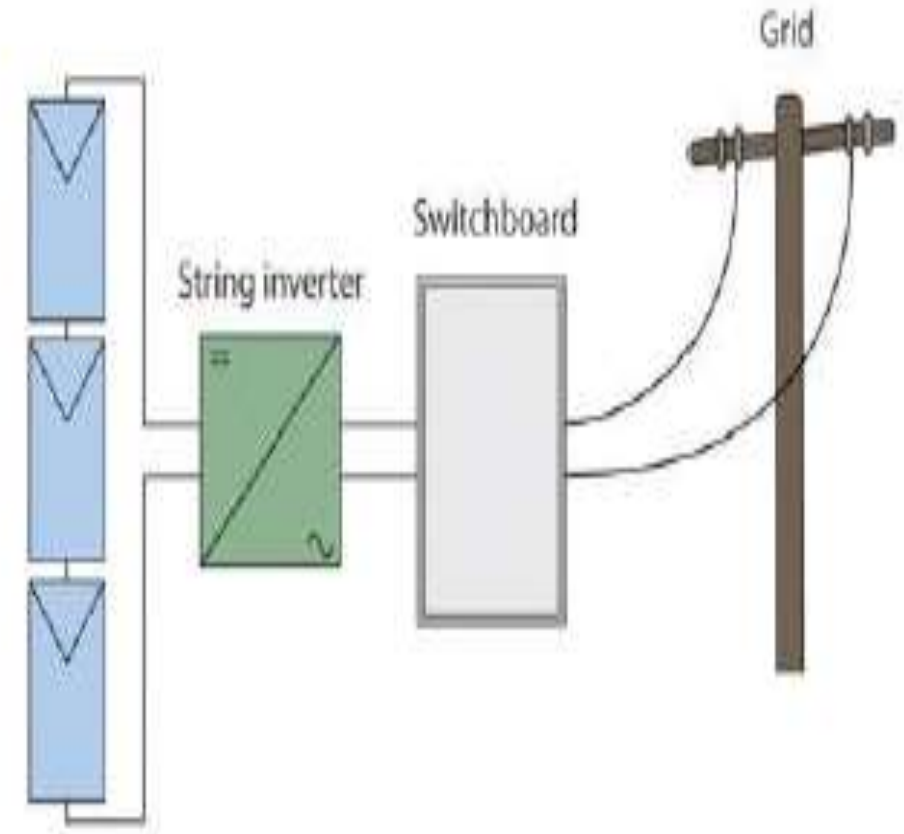

Multi-string inverter

- A multi-string inverter is a single inverter appliance, but it has a number of MPPT inputs.
- Therefore the PV array can be divided into multiple strings and a suitable combination of strings connects to each one of the inverter's MPPT inputs.
- These inverters have the advantage that if the modules are facing different directions then the array could be divided into strings so that modules in the same string are all facing the same direction

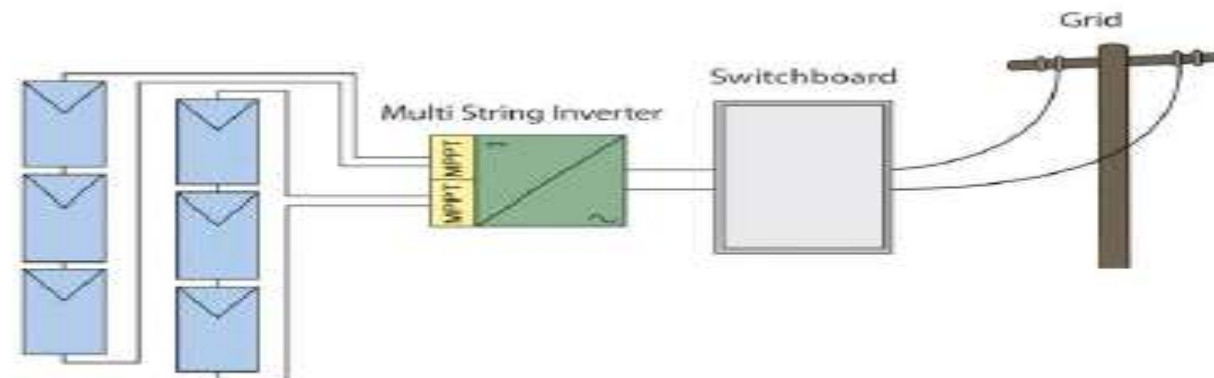

Figure 5.13 Two strings are each connected to different MPPTs so that if one is shaded it will not reduce the output of the other

Source: Global Sustainable Energy Solutions

- These individual strings then connect to a dedicated MPPT so that the energy yield from the system is higher than a single string system
- A multi-string inverter is generally cheaper than using a number of individual inverters and can offer the advantage of higher energy output for arrays where parts of the array face different directions or experience different levels of shading.

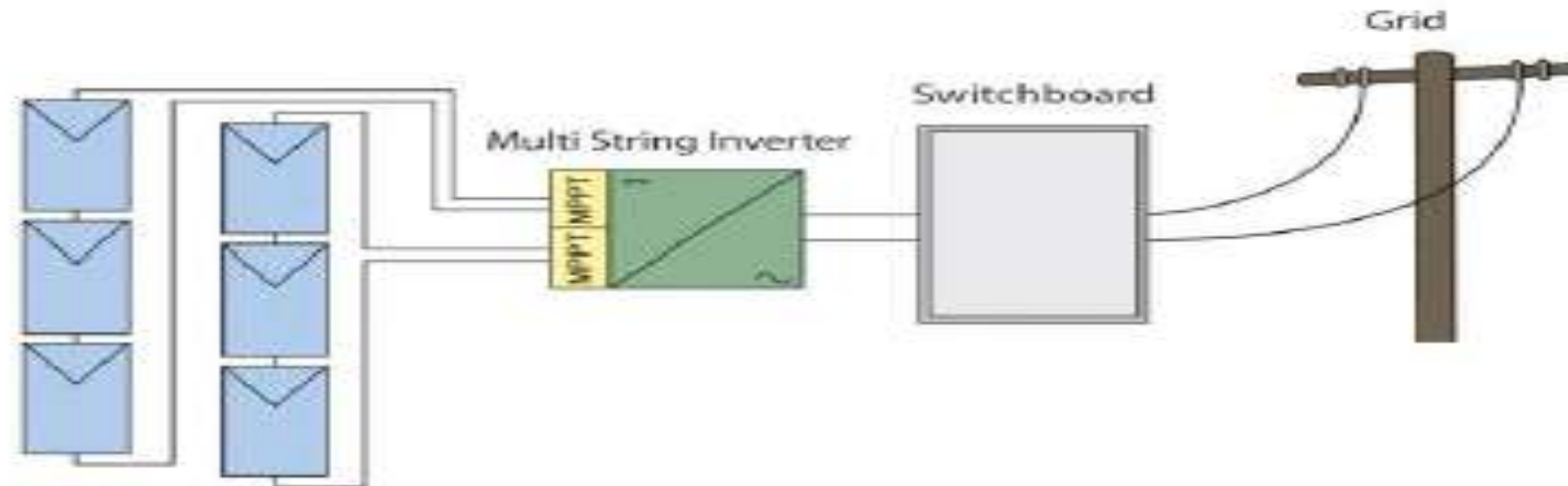

Figure 5.13 Two strings are each connected to different MPPTs so that if one is shaded it will not reduce the output of the other

Source: Global Sustainable Energy Solutions

Central inverter

- A central inverter is very similar to the string inverter with multiple strings – the difference is that central inverters are generally used for a large system (>10kWp).
- In these systems the array could be divided into a number of sub arrays, each comprising a number of strings.
- In some systems there is just one large inverter suitable for the whole array
- In others there will be a number of inverters, for example $5 \times 20\text{kW}$ inverters for a 100kW system.

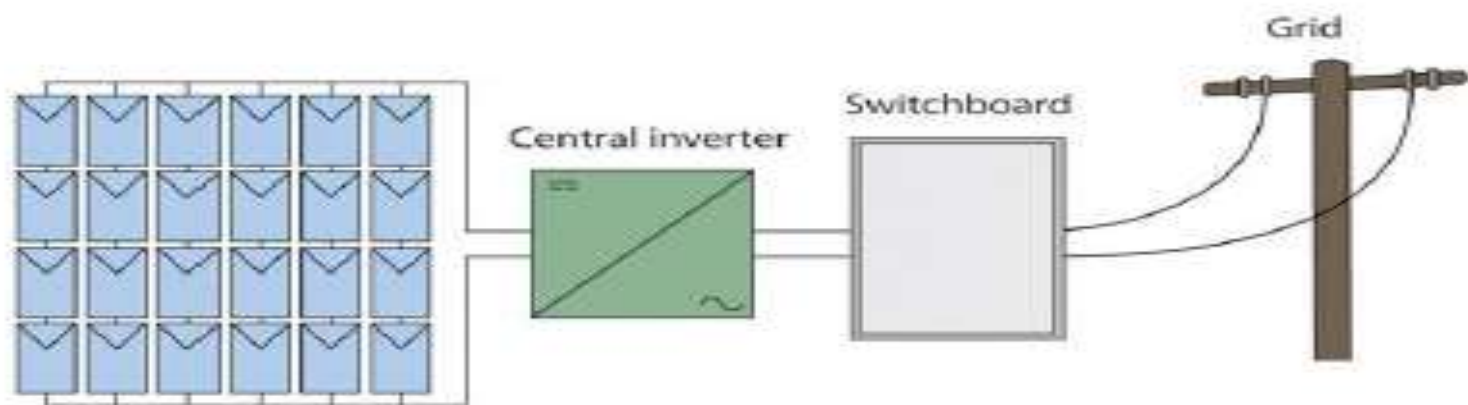

Figure 5.14 Connecting multiple strings to a central inverter

Source: Global Sustainable Energy Solutions



Figure 5.15 For very large installations a whole room of central inverters may be required. These are SMA Sunny Mini Central inverters

Source: SMA Solar Technology AG

Modular/micro/hybrid inverters

- Modular inverters (some will have an isolating transformer to minimize DC injection currents) designed to be mounted on the back of the PV module.
- Two main advantages of the modular inverter are that they remove the requirement for DC cabling from the array as each module has an AC output
- each module inverter output lands on a fuse terminal and the output of the fused inputs are combined onto a single combiner box
- These inverters are also small and easy to handle, and they have the advantage of being modular which means that more modules and inverters can be added to the system in future at minimum cost.

- The disadvantages of modular inverters are related to the fact that they are installed on the back of PV modules.
- If the inverter fails, repairing or replacing it involves removing the modules from the array to access the inverter behind it.



Figure 5.16 Micro-inverter attached to the back of a module

Source: Global Sustainable Energy Solutions

- In addition, designers may be wary of using modular inverters in hot climates.
- PV modules heat up considerably during the day, so the inverter will operate at a higher temperature than it would be if it were located on a shaded wall or indoors, increasing the risk of inverter failure.

Table 5.1 Inverter types and characteristics

Inverter type	Modular	String	Multi-string	Central
Power range	100–300W	700–11,000W	2000–17,000W	10,000–300,000W
MPPT	Yes	Yes	Multiple	Multiple
Typical efficiency	95%	93–97%	97%	97%
Advantages	No DC cabling; easy to add more modules	Readily available	Multiple MPPTs; readily available	Lower \$/W cost; one location for maintenance
Disadvantages	Replacing a faulty inverter can be difficult	Only one MPPT		No redundancy if inverter fails

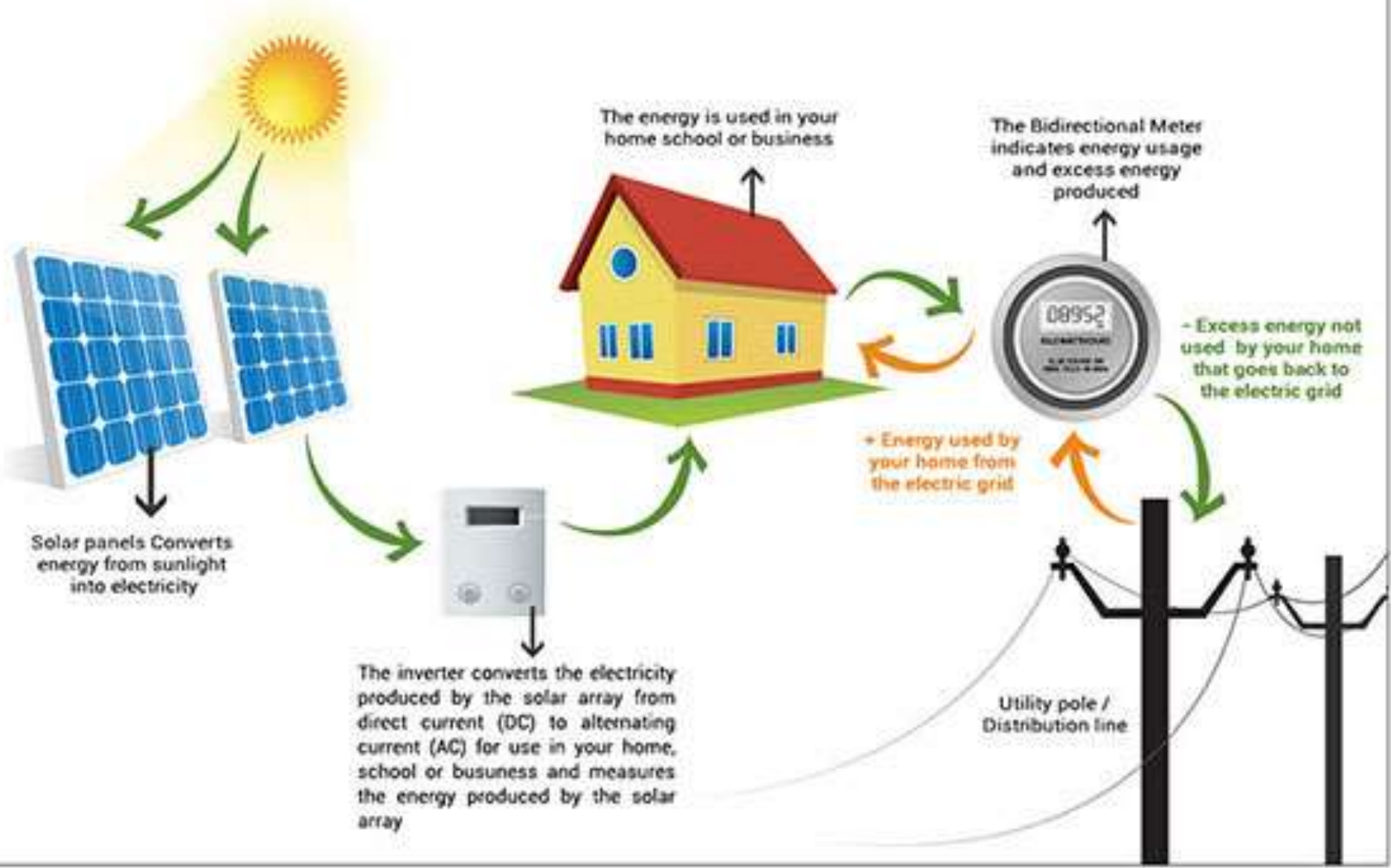

Solar panels Converts energy from sunlight into electricity

The energy is used in your home school or business

The Bidirectional Meter indicates energy usage and excess energy produced

- Excess energy not used by your home that goes back to the electric grid

+ Energy used by your home from the electric grid

The inverter converts the electricity produced by the solar array from direct current (DC) to alternating current (AC) for use in your home, school or business and measures the energy produced by the solar array

Utility pole / Distribution line

Inverter protection systems

- Grid-interactive inverters will typically incorporate two types of protection: **active and passive.**
- Both forms have the inverter switch off on over/under frequency or over/under voltage.
- **Active: self-protection for the inverter** if extreme conditions occur
- **Passive : Protection for the grid** itself, so the inverter will disconnect if it cannot see the grid, e.g. if there is a blackout

6

Mounting Systems

This chapter discusses different techniques used to mount PV arrays. First, roof mounting systems are explored; these are commonly used in small-scale urban installations and four different techniques are covered. Second, two different techniques for ground mounting systems are explained; ground-mounted systems are generally used for very large installations but may also be used for small installations on large properties where space is plentiful, such as farms. Sun-tracking systems that turn PV modules to follow the path of the sun and capture a larger amount of solar radiation are also explained. The chapter concludes with a discussion of the safety issues surrounding mounting systems.

It is important that installers familiarize themselves with the local requirements for the installation of a PV array. Some regions require that an approval process be met before the installation is allowed. It is important that the manufacturer's installation guidelines are followed so that the product warranty is not compromised and any structural certification remains valid. Always ensure that the mounting system is compatible with the PV modules to be installed.

Roof mounting systems

For homes or businesses using a grid-connected PV array, the most common installation is the rooftop mounting system. Its most important role is to securely and safely attach the solar array to the roof. Aside from safety there are three other important factors to consider when choosing a roof mounting system: the amount of solar radiation the module will receive in that position, ventilation of the module and the overall aesthetics of the PV system.

The amount of solar radiation the module receives (the module's solar access) will directly affect the power it produces and therefore should be optimized by using a mounting system that secures the array at optimal orientation and tilt angle for that location. In cases where attaching modules at the angle and direction of the roof will not yield this result, installers may consider using a mounting system that can elevate the modules to face the optimum tilt angle and orientation and so improve the modules' power output.

Ideally a mounting system should allow for as much clearance as possible above the roof in order to increase the flow of air around the modules. This ventilation provides convective cooling and can reduce the temperature the

modules heat up to during the day. As discussed in Chapter 3, modules perform better at cooler temperatures and ventilation can improve the performance of the array, while not allowing any ventilation behind the modules is likely to decrease the modules' output.

Figure 6.1 This mounting scheme allows good ventilation. Mounting panels closer to the roof increases operating temperature and thereby lowers system performance

Source: Global Sustainable Energy Solutions



Figure 6.2 This mounting scheme will not permit good airflow

Source: Global Sustainable Energy Solutions



The aesthetics of the PV system is often a priority for homeowners. Systems discreetly installed close to the roof, blending with the architecture, are often considered more aesthetically pleasing. This visual appeal comes at a cost, particularly to ventilation. When modules are installed close to the roof, heat will have less chance of escaping from underneath the array than if the modules were elevated above the roof. Thus, low-profile mounting means the PV modules will probably operate at higher temperatures, with reduced power output as a result. Additionally a system installed close to the roof will follow the tilt angle and orientation of the roof; if these are not optimal then it will adversely affect the power output of the PV array.

The balance between these trade-offs is complex and the installer should provide the customer with information regarding the trade-offs and expected performance of the system using each mounting system so that the customer can make an informed decision. The different types of roof mounting systems are outlined below. All these are fixed systems, which do not move and, as explained, each has its own unique benefits.

Pitched roof mounts

Pitched roof mounts are the most common roof-mounted system because they are versatile, easy to install and relatively inexpensive. These systems are typically mounted just above the roof surface at the same orientation and tilt angle as the roof. Pitched roof mounts are normally attached to the roof's structural members, e.g. the rafters, through the use of lag bolts or fixing brackets.

A horizontal railing system is then attached to these brackets and modules are secured to the railing through the use of module clamps. In this way the railing elevates the modules above the roof surface and allows for increased air circulation under the array. Pitched roof mounts are popular because they allow for some ventilation around the module while still keeping a fairly low profile and are thus considered an excellent balance between aesthetics and ventilation. Commonly used materials in pitched roof mounting systems include aluminium, stainless and galvanized steel.

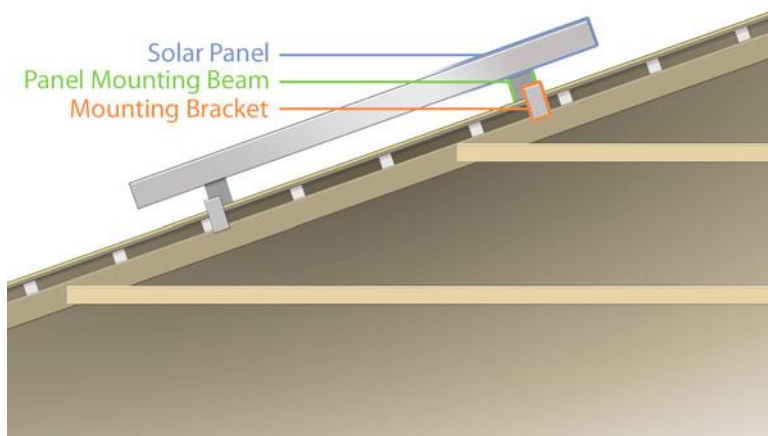

Figure 6.3 Pitched roof or standoff mounts are normally attached to rafters

Source: Global Sustainable Energy Solutions