

Internal Assessment Test 3 – Nov. 2019

Sub:	Fluid Power Systems					Sub Code:	15ME72	Branch:	ME	
Date:	16/11/2019	Duration:	90 min's	Max Marks:	50	Sem / Sec:	7 th sem A & B		OBE	
<u>Answer any FIVE FULL Questions</u>								MARKS	CO	RBT
1. (a)	What are the characteristics of compressed air? Explain them.					[05]	CO1	L2		
	(b) Differentiate hydraulic and pneumatic systems.					[05]	CO1	L1		
2.	Sketch and explain structure of pneumatic control system.					[10]	CO4	L2		
3.	Sketch and explain construction and principle of working of a quick exhaust valve.					[10]	CO4	L2		
4.	List different types of compressors. Explain with a neat sketch the production of compressed air.					[10]	CO4	L3		
5.	Describe the end-cushioning effect, in a pneumatic linear actuator with sketch.					[10]	CO2	L3		
6.	What is FRL unit in a pneumatic system? Explain.					[10]	CO4	L2		
7.	What are the application of shuttle valve and two pressure valve? Explain with a neat diagram.					[10]	CO4	L2		
8.	Write short notes on: 1. Magnetic type rod less cylinder 2. Cylinder mountings.					[10]	CO2	L2		

CI**CCI****HOD****Scheme of Evaluation IA Test 3 – Nov. 2018**

Sub:	Fluid Power Systems					Sub Code:	15ME72	Branch:	ME	
Date:	19/11/2018	Duration:	90 min's	Max Marks:	50	Sem / Sec:	7 th sem A & B		OBE	
<u>Answer any FIVE FULL Questions</u>								MARKS	CO	RBT
1. (a)	Any five characteristics of compressed air. Explain each of them.					[5*1=5]	CO1	L2		
	(b) Differentiate hydraulic and pneumatic systems.					[5*1=5]	CO1	L1		
2.	Sketch and explain structure of pneumatic control system.					[6+4]	CO4	L2		
3.	Sketch and explain construction and principle of working of a quick exhaust valve.					[5+5]	CO4	L2		
4.	List different types of compressors. Explain with a neat sketch the production of compressed air.					[4+4+2]	CO4	L3		
5.	Describe the end-cushioning effect, in a pneumatic linear actuator with sketch.					[6+4]	CO2	L3		
6.	FRL unit in a pneumatic system. Neat sketch and explanation.					[6+4]	CO4	L2		
7.	What are the application of shuttle valve and two pressure valve? Explain with a neat diagram.					[5+5]	CO4	L2		
8.	Write short notes on: a. Magnetic type rod less cylinder b. Cylinder mountings.					[5+5]	CO2	L2		

CI**CCI****HOD**

1. (a)	What are the characteristics of compressed air? Explain them.	
	Availability	Air is available practically everywhere in unlimited quantities.
	Transport	Air can be easily transported in pipelines, even over large distances.
	Storage	Compressed air can be stored in a reservoir and removed as required. In addition, the reservoir can be transportable.
	Temperature	Compressed air is relatively insensitive to temperature fluctuations. This ensures reliable operation, even under extreme conditions.
	Explosion proof	Compressed air offers no risk of explosion or fire.
	Cleanliness	Unlubricated exhaust air is clean. Any unlubricated air which escapes through leaking pipes or components does not cause contamination.
	Components	The operating components are of simple construction and therefore relatively inexpensive.
	Speed	Compressed air is a very fast working medium. This enables high working speeds to be attained.

(b)	Differentiate hydraulic and pneumatic systems.	
	Hydraulic system	Pneumatic system
	It employs a pressurized liquid as fluid	it employs a compressed gas usually air as a fluid
	Oil hydraulics system operates at pressures upto 700 bar.	Pneumatics systems usually operate at 5 to 10 bar.
	Generally designed for closed systems	Pneumatic systems are usually designed as open system
	System get slow down of leakage occurs	Leakage does not affect the system much more
	Valve operations are difficult	Easy to operate the valves
	Heavier in weight	Light in weight
	Pumps are used to provide pressurized liquids	Compressors are used to provide compressed gas
	System is unsafe to fire hazards	System is free from fire hazards
	Automatic lubrication is provided	Special arrangements for lubrication needed.

2.	<p>Sketch and explain structure of pneumatic control system.</p> <p>Important components of a pneumatic system are shown in fig.</p> <p>a) Air filters: These are used to filter out the contaminants from the air.</p> <p>b) Compressor: Compressed air is generated by using air compressors. Air compressors are either diesel or electrically operated. Based on the requirement of compressed air, suitable capacity compressors may be used.</p> <p>c) Air cooler: During compression operation, air temperature increases. Therefore coolers are used to reduce the temperature of the compressed air.</p> <p>d) Dryer: The water vapor or moisture in the air is separated from the air by using a dryer.</p> <p>e) Control Valves: Control valves are used to regulate, control and monitor for control of direction flow, pressure etc.</p> <p>f) Air Actuator: Air cylinders and motors are used to obtain the required movements of mechanical elements of pneumatic system.</p> <p>g) Electric Motor: Transforms electrical energy into mechanical energy. It is used to drive the compressor.</p> <p>h) Receiver tank: The compressed air coming from the compressor is stored in the air receiver.</p>
----	---

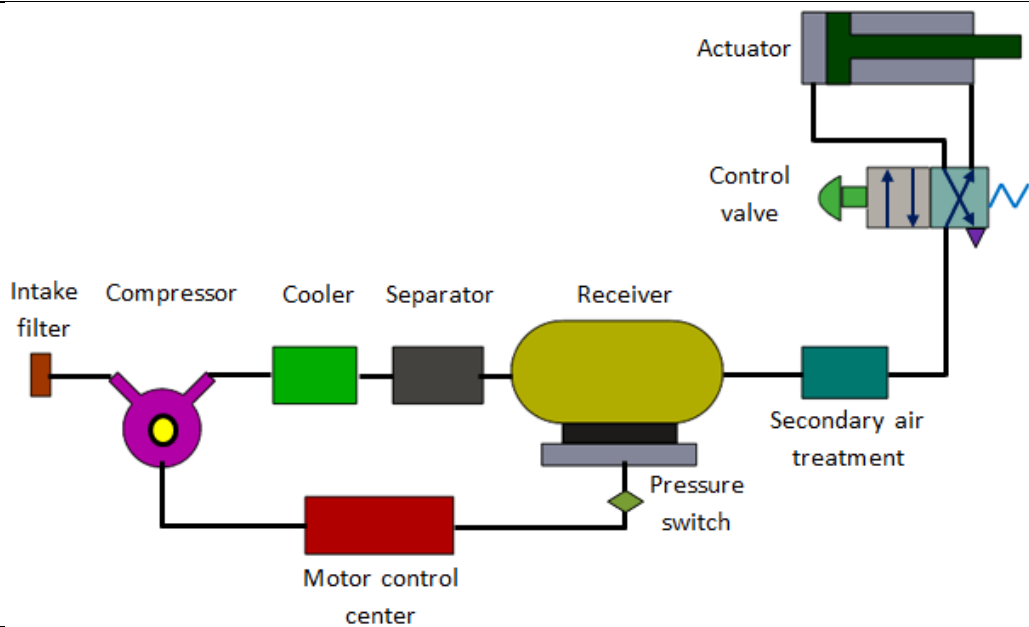

3. Sketch and explain construction and principle of working of a quick exhaust valve.
 A quick exhaust valve is a typical shuttle valve. The quick exhaust valve is used to exhaust the cylinder air quickly to atmosphere. Schematic diagram of quick exhaust valve is shown in Figure 4.38(a). In many applications especially with single acting cylinders, it is a common practice to increase the piston speed during retraction of the cylinder to save the cycle time. The higher speed of the piston is possible by reducing the resistance to flow of the exhausting air during the motion of cylinder. The resistance can be reduced by expelling the exhausting air to the atmosphere quickly by using Quick exhaust valve.

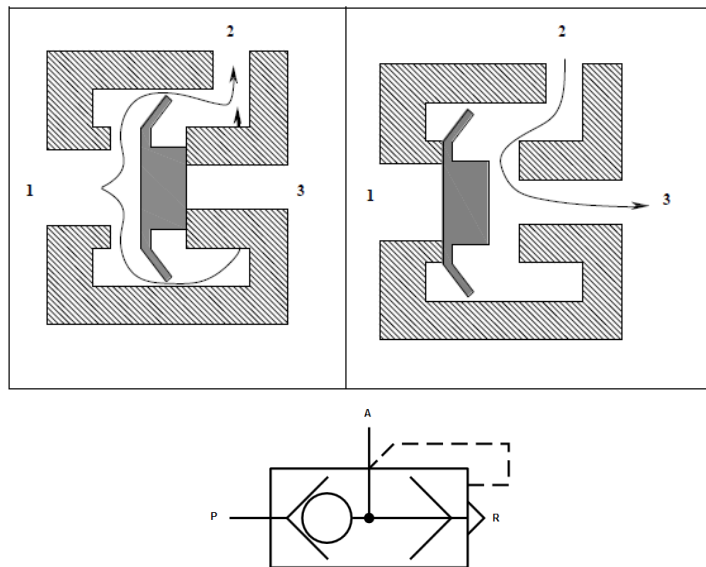

It consists of a movable disc (also called flexible ring) and three ports namely, Supply port 1, which is connected to the output of the directional control valve. The Output port, 2 of this valve is directly fitted on to the working port of cylinder. The exhaust port, 3 is left open to the atmosphere.

Forward Motion: During forward movement of piston, compressed air is directly admitted to cylinder inlet through ports 1 and 2. Port 3 is closed due to the supply pressure acting on the diaphragm. Port 3 is usually provided with a silencer to minimize the noise due to exhaust.

Return Motion: During return movement of piston, exhaust air from cylinder is directly exhausted to atmosphere through opening 3 (usually larger and fitted with silencer) .Port 2 is sealed by the diaphragm. Thus exhaust air is not required to pass through long and narrow passages in the working line and final control valve.

4. List different types of compressors. Explain with a neat sketch the production of compressed air.
 Air compressors are generally positive displacement units and either of reciprocating piston type or the rotary screw or rotary vane types. These three types are explained.

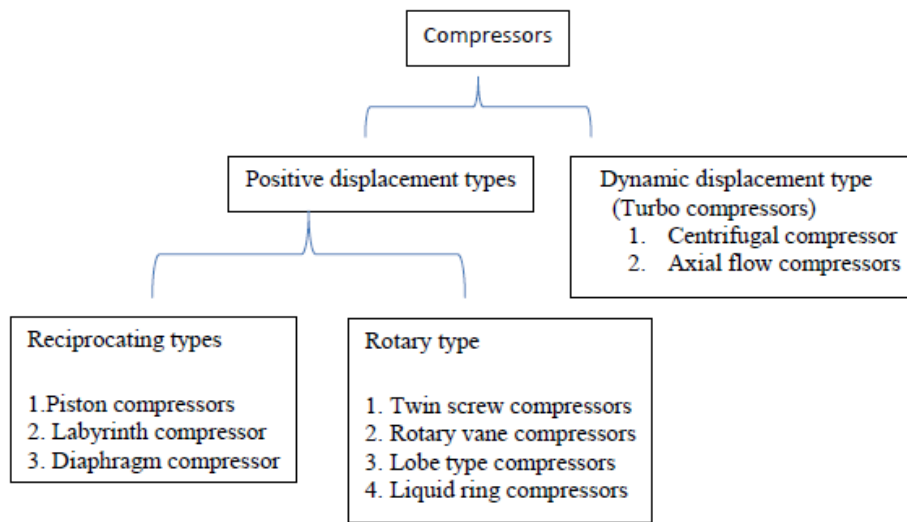

For satisfactory operation of the pneumatic system the compressed air needs to be cleaned and dried. Atmospheric air is contaminated with dust, smoke and is humid. These particles can cause wear of the system components and presence of moisture may cause corrosion. Hence it is essential to treat the air to get rid of these impurities. The air treatment can be divided into three stages as shown in Figure.

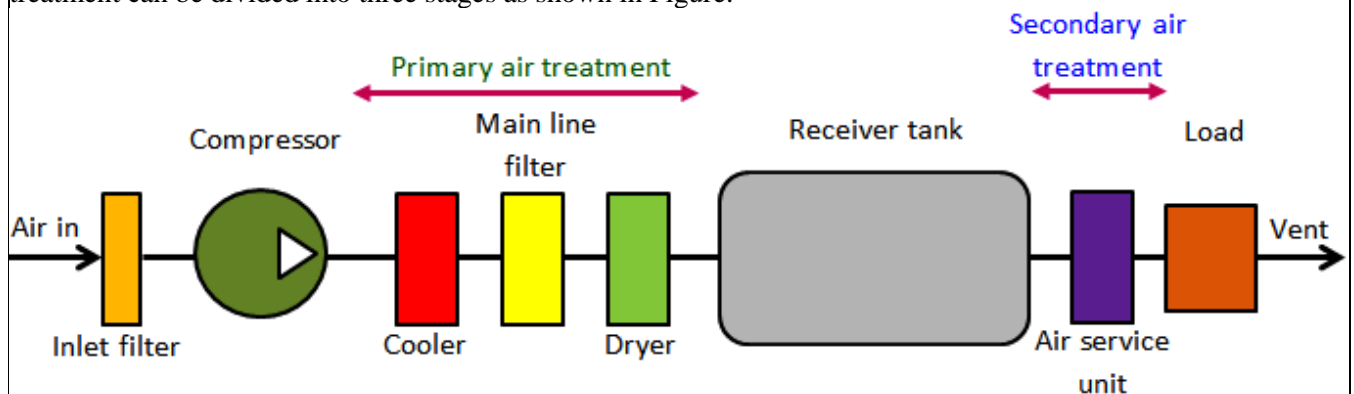

5. Describe the end-cushioning effect, in a pneumatic linear actuator with sketch.
- Double acting cylinders generally contain cylinder cushions at the end of the cylinder to slow down the movement of the piston near the end of the stroke. Figure 6.4.3 shows the construction of actuating cylinder with end cushions. Cushioning arrangement avoids the damage due to the impact occurred when a fast moving piston is stopped by the end caps. Deceleration of the piston starts when the tapered plunger enters the opening in the cap and closes the main fluid exit. This restricts the exhaust flow from the barrel to the port. This throttling causes the initial speed reduction. During the last portion of the stroke the oil has to exhaust through an adjustable opening since main fluid exit closes. Thus the remaining fluid exists through the cushioning valve. Amount of cushioning can be adjusted by means of cushion screw. A check valve is provided to achieve fast break away from the end position during retraction motion. A bleed screw is built into the check valve to remove the air bubbles present in a hydraulic type system.

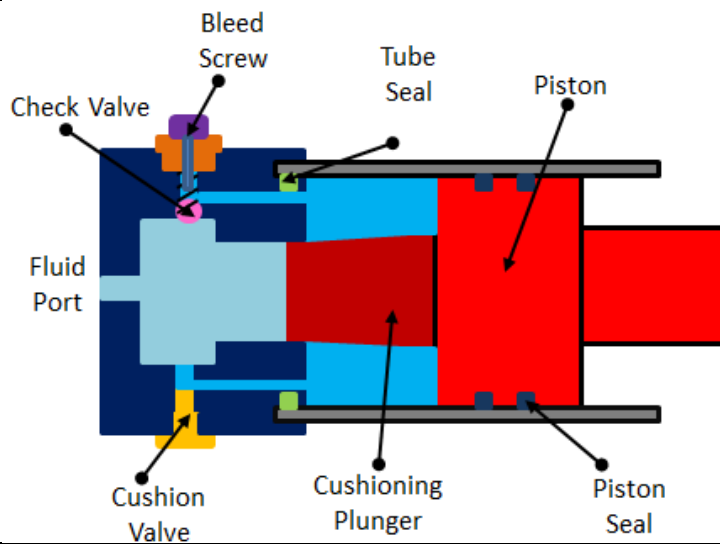

6. What is FRL unit in a pneumatic system? Explain.
 During the preparation of compressed air, various processes such as filtration, regulation and lubrication are carried out by individual components. The individual components are: separator/filter, pressure regulator and lubricator.
 Preparatory functions can be combined into one unit which is called as 'service unit'. Figure below shows symbolic representation of various processes involved in air preparation and the service unit.

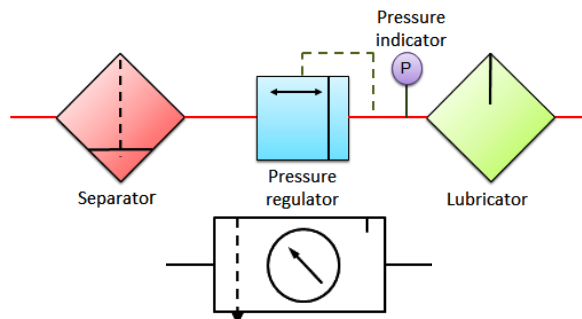

7. What are the application of shuttle valve and two pressure valve? Explain with a neat diagram.
A shuttle valve is shown in figure. The shuttle valve consists of a valve body and a synthetic ball or a cuboid valving element moving inside the bore in the valve housing. There are three openings P1, P2, and A. if an air signal is fed to port P1, the ball moves, closing port P2 and air passes to 'A'. If the air is fed to port P2, port P1 is closed and moves to 'A'. If air is fed simultaneously to port P1 and P2 then also air moves to port A, either from P1 or P2 or from both. This element is also called an OR Gate.

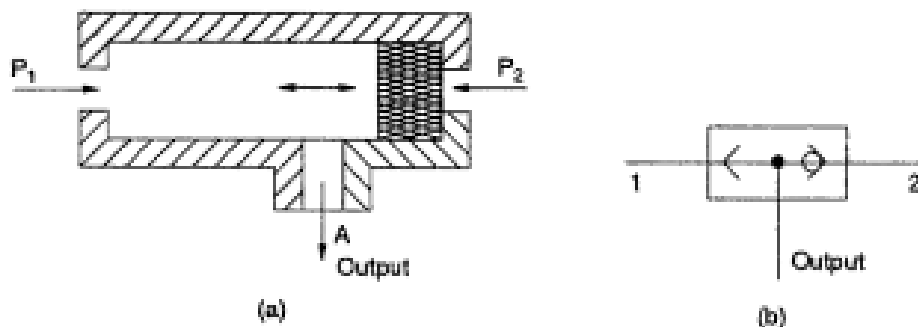

Two pressure valve: This valve is also called as pneumatic AND valve. A two pressure valve requires two pressurized inputs to allow an output from itself. The cross sectional views of two pressure valve in two positions are given in Figure 4.41. As shown in the figure, this valve has two inputs X and Y and one output A. If the compressed air is applied to either X or input Y, the spool moves to block the flow, and no signal appears at output A. If signals are applied to both the inputs X and Y, the compressed air flows through the valve, and the signal appears at output A.

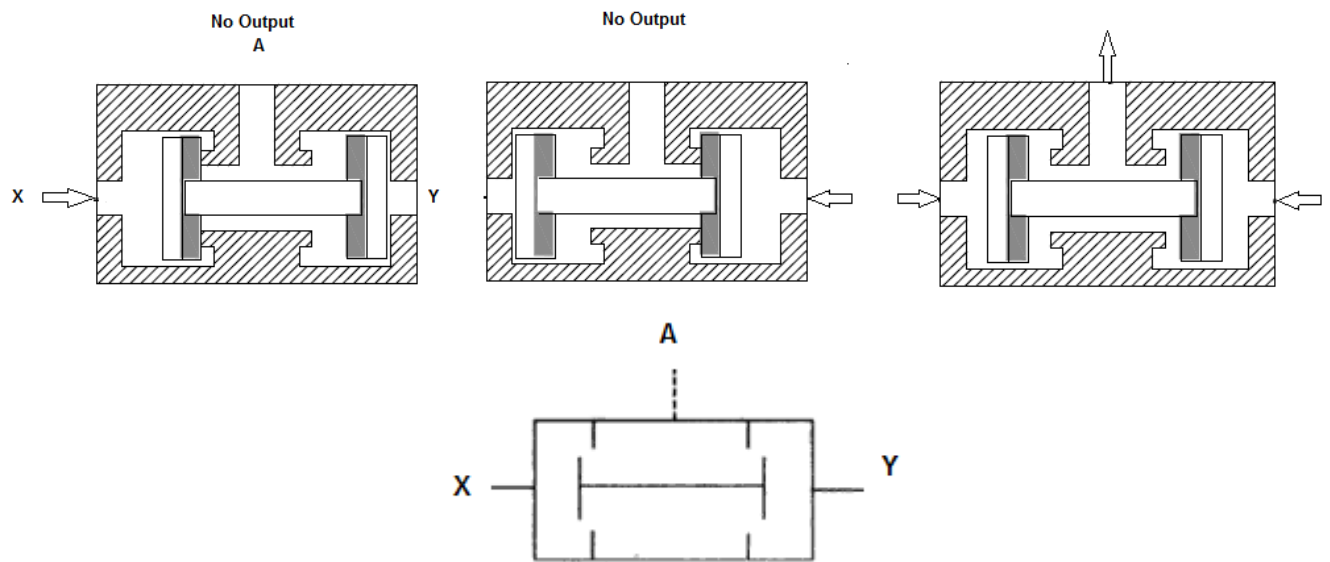

8. Write short notes on: 1. Magnetic type rod less cylinder 2. Cylinder mountings.

1. Magnetic type rod less cylinder

Rodless cylinders mount a piston follower on the outside of the cylinder. The simplest construction, shown in Figure 5.13a, uses a magnetic external follower to track the position of a magnetic piston. The maximum force that this type of cylinder can provide is set by the breakaway force between the piston and the follower.

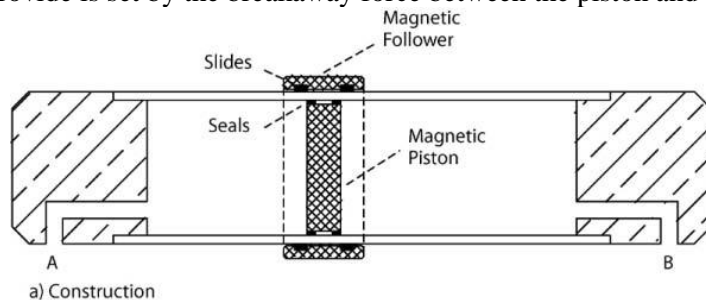

An alternative, but more complex, design has a physical connection between the piston and the follower. This connection link passes through a slot in the cylinder wall which is sealed by magnetic strip seals either side of the link. Although capable of providing the full force of which the cylinder is capable, the seal is vulnerable to dust intrusion which may cause leaks from the seal.

2. Cylinder mountings

The way in which the pneumatic cylinder is mounted similar to hydraulic cylinders influences service life, maintenance frequency and success of the entire installation. Poor mounting design can cause excessive side loads and stresses which will bring about early failure of some vital component. There are three main categories of cylinder mounting. The selection of these mountings depends on the application and machine configuration.

1. Fixed Centreline mountings
2. Pivoted centreline mountings
3. Fixed non centreline mountings

1. Fixed Centreline mountings: In this mounting, the cylinder is supported along its centre line. The mounting bolts are thus subjected to shear or simple stress. This mounting needs accurate alignment. Misalignment is not tolerable.

2. Pivot centreline mounting: Many applications need rotational degree of freedom for a cylinder as it reciprocates. The pivot mounting can be clevis type or trunnion type. This mounting permits rotational freedom in one plane. If universal joint is used, greater degrees of freedom are possible.

3. Fixed non centreline mounting: This mounting of cylinder introduces torque under loaded condition. The cylinder may rotate or bend about its mounting bolt when loaded. The stress level on the cylinder is higher as compared to the centre line mounting.

