

Seventh Semester B.E. Degree Examination, June/July 2017
Design of Steel Structures

Time: 3 hrs.

Max. Marks: 100

- Note:** 1. Answer FIVE full questions, selecting at least TWO questions from each part.
 2. Use of IS: 800-200 and steel tables is permitted.

PART - A

- 1
 - a. Describe briefly advantages and disadvantages of steel structures. (05 Marks)
 - b. What are the different loads and load combinations to be considered in the design of steel structure. (05 Marks)
 - c. Explain rolled steel sections. What are the different types of rolled steel section used in construction? (06 Marks)
 - d. Explain briefly the limit state method of design of steel structure. (04 Marks)
- 2
 - a. Briefly explain different types of bolts. (04 Marks)
 - b. Determine the safe load P that can be carried by the bracket. The bracket plate is of 10mm thick M20 bolt of grade 5.6 are used. (16 Marks)

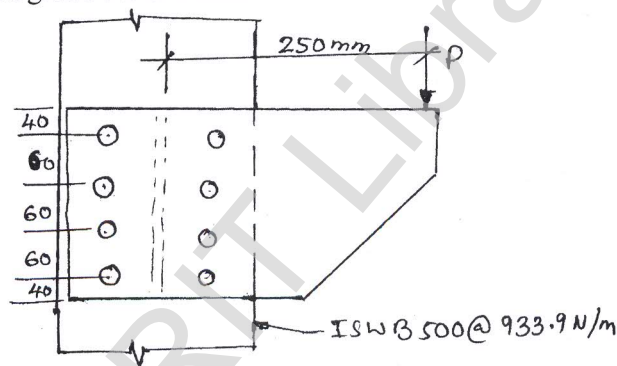

Fig Q2(b)

- 3
 - a. Describe briefly advantages and disadvantages of welded connection. (04 Marks)
 - b. What are the common defects in welding? Explain with neat sketch. (06 Marks)
 - c. A tension member consists of 2ISA 100×75×8 carries a factored tensile load of 300kN. The angles are connected to a 10mm thick gusset plate with longer legs placed back to back on either side of gusset plate. Design the joint assuming shop welding and only side weld are provided. (10 Marks)
- 4
 - a. Define i) Plastic hinge ii) Mechanism iii) Shape factor. (06 Marks)
 - b. Find out the collapse load for a propped cantilever subjected to a concentrated load at the midspan of the beam using upper bound theorem. (04 Marks)
 - c. Determine the plastic moment capacity (M_p) for the beam loaded as shown in Fig Q4(c). Use load factor 1.6. (10 Marks)

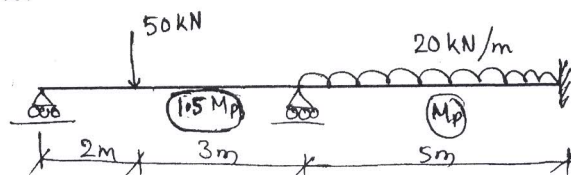

Fig Q4(c)

PART – B

- 5 a. Explain different forms of tension members commonly used in steel structures. (04 Marks)
b. Design a single unequal angle tension member to carry a factored load of 300kN. The length of the member is 3.0m. The tension member is connected to a gusset plate of 16mm thick with one line of M20 bolts of grade 8.8. Take pitch = 60mm and edge distance = 40mm. use steel of Fe 410. (16 Marks)
- 6 a. Calculate the design strength of discontinuous strut of length 3.2m. The strut consists of two unequal angles $100 \times 75 \times 8$ with longer legs placed back to back on either side of 10mm thick gusset plate. Assume steel of grade Fe 410. (06 Marks)
b. Design a single lacing system for a column 8m long consists of 2 ISMC 300 placed back to back such that $I_{zz} = I_{yy}$. The column is subjected to factored load of 1250kN and is hinged at both ends. Assume steel of grade Fe 410 and bolts are of grade 4.6. (14 Marks)
- 7 Design a suitable bolted gusseted base for a built up column consists of ISHB 350@ 661.2N/m with cover plate of 400mm \times 20mm on either flange carrying a axial compressive factored load of 2400kN. The box rests on M20 grade of concert pedestal. Use M24 bolts of grade 5.6 for making connection. Sketch the details. (20 Marks)
- 8 Design a steel beam for supporting RC slab with clear span of 5.0m thickness of end bearing wall 230mm. total service load acting on this floor is 10kN/m^2 . The beams are provided at 3.5m C/C. The compression flange is laterally supported throughout its length. Design should satisfy all necessary checks. (20 Marks)

* * * * *