

CBCGS SCHEME

18ME52

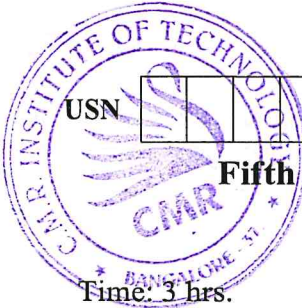

Fifth Semester B.E. Degree Examination, Feb./Mar. 2022 Design of Machine Elements – I

Time: 3 hrs.

Max. Marks: 100

- Note:** 1. Answer any FIVE full questions, choosing ONE full question from each module.
2. Use of design data handbook is permitted.

Module-1

- 1 a. Explain the factors which influence the selection of engineering materials. (05 Marks)
- b. Explain codes and standards. List any four organizations who have established specifications for standards and codes. (05 Marks)
- c. A machine member 60mm diameter is subjected to combined loading as shown in Fig.Q1(c). Determine the maximum principal stress and maximum shear stress at point P.

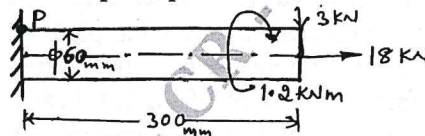

Fig.Q1(c)

(10 Marks)

OR

- 2 a. Explain even and uneven materials with the help of Mohr's circles. (04 Marks)
- b. State and explain the following theories of failure:
 - (i) Maximum normal stress theory
 - (ii) Maximum shear stress theory
 - (iii) Distortion energy theory (Hencky Von-Mises theory) (06 Marks)
- c. A flat bar as shown in Fig.Q2(c) is subjected to an axial pull of 100 kN. Calculate its thickness if allowable tensile stress is 180 MPa.



Fig.Q2(c)

(10 Marks)

Module-2

- 3 a. Obtain an expression for impact stress induced in a member subjected to axial load. (05 Marks)
- b. A steel rod 1.5m long has to resist longitudinally an impact of 2.5 kN falling under gravity at a velocity of 0.9925 m/s. The maximum computed stress is to be limited to 150 MPa. Determine the diameter of the round rod. Take $E = 210 \text{ GPa}$. (07 Marks)
- c. A beam of I-section 250mm depth has a moment of inertia of $60 \times 10^6 \text{ mm}^4$. It is simply supported at the ends at a distance of 3m apart. A weight of 3 kN falls at its middle from an unknown height. Determine the safe height 'h' taking the allowable stress as 90 MPa. Take $E = 210 \text{ GPa}$. (08 Marks)

OR

- 4 a. Obtain Soderberg's relation for a member subjected to fatigue loading. (05 Marks)
- b. A steel connecting rod of rectangular cross-section having depth twice that of the width is subjected to a completely reversed axial load of 18 kN. The endurance stress is 300 MPa and yield stress is 420 MPa. Determine suitable cross-sectional dimensions of the connecting rod. Take size factor = 0.9, Load factor = 0.7, Surface factor = 0.85, Stress concentration factor = 1.5, Notch sensitivity = 1. Factor of safety = 1.8. Neglect column effect. (07 Marks)

- c. A steel rod ($\sigma_y = 400.1$ MPa and $\sigma_{-1} = 345.2$ MPa) of circular cross-section shown in Fig.Q4(c) is subjected to load varying from $3F$ to F . Determine the value of F . Use a factor of safety 3. Take stress concentration factor = 1.43, $q = 1$.

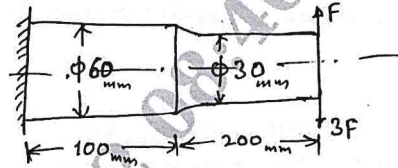

Fig.Q4(c)

Load factor = 1.0 , Size factor = 0.85, Surface factor = 0.85.

(08 Marks)

Module-3

- 5 A commercial steel shaft 1m long supported between bearings carries a pulley of diameter 600mm weighing 1 kN located 400mm to the right of the right hand bearing and receives 25 kW at 1000 rpm by a horizontal belt drive. The power from the shaft is transmitted by a spur pinion of 20° pressure angle having pitch circle diameter 200mm to a spur gear such that the tangential force on gear acts vertically upwards. The pinion is keyed to the shaft at a distance of 200mm to the right of the left bearing. Taking the ratio of belt tensions as 3, determine the diameter of the shaft required. Use maximum shear stress theory. Take $\tau_d = 40$ N/mm².

(20 Marks)

OR

- 6 a. Select a rectangular sunk key to transmit 9 kW at 300 rpm. The yield stress for the steel used is 310 MPa. Take factor of safety as 2.5 . (06 Marks)
- b. Design a rigid flange coupling (Un-protected) to transmit 18 kW at 1440 rpm. The allowable shear stress for CI flange is 4 MPa. The shafts, keys and bolts are made of annealed steel having allowable shear stress of 93 MPa. Take allowable crushing stress = 186 MPa for key. Take key way factor $\eta = 0.75$ for shaft. (14 Marks)

Module-4

- 7 a. Design a longitudinal joint for a boiler of 2m diameter subjected to a pressure of 1 MPa. The joint is a triple riveted butt joint with equal covers and efficiency of 85%. The pitch of the outer row is twice the pitch of inner rows. The arrangement is of chain type. Take allowable stress in tension = 117.67 N/mm², in shear = 70.6 N/mm² and in crushing = 176.50 N/mm². Take coefficient $k_1 = 6$ and corrosion allowance of 2 mm. (12 Marks)
- b. A bracket attached to a vertical column by means of four identical rivets, is subjected to an eccentric force of 25 kN as shown in Fig.Q7(b). Determine the diameter of rivets, if the permissible shear stress is 60 N/mm².

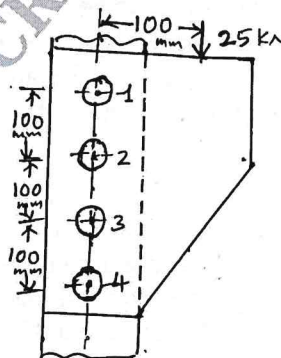

Fig.Q7(b)

(08 Marks)

OR

- 8 a. A welded connection as shown in Fig.Q8(a) is subjected to an eccentric force of 60 kN in the plane of the welds. Determine the size of the welds, if the permissible shear stress for the weld is 100 N/mm^2 . Assume static conditions.

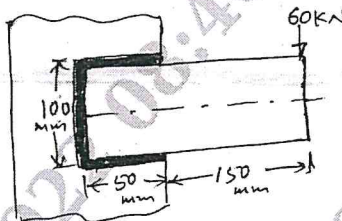

Fig.Q8(a)

(12 Marks)

- b. Determine the load carrying capacity of a welded joint loaded as shown in Fig.Q8(b). The allowable shear stress for 10mm weld used is 50 MPa.

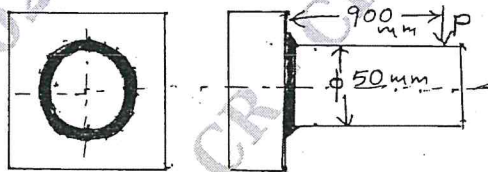

Fig.Q8(b)

(08 Marks)

Module-5

- 9 a. It is required to design a cottor joint to connect two steel rods of equal diameter. Each rod is subjected to axial tensile force of 50 kN. Design the joint and specify main dimensions. Take permissible stresses for rods in tension = 67 N/mm^2 . Crushing = 134 N/mm^2 and for cottor in tension = 100 N/mm^2 . (08 Marks)
- b. Explain self-locking in power screws. (02 Marks)
- c. A bracket is bolted as shown in Fig.Q9(c). All the bolts are of same size and are made of steel having allowable tensile stress of 90 MPa and allowable shear stress of 52 MPa. Determine the size of the bolts to be used.

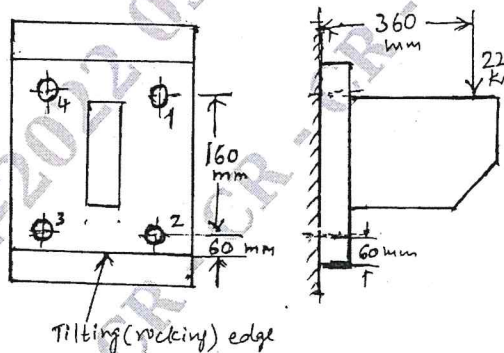

Fig.Q9(c)

(10 Marks)

OR

- 10 a. Obtain an expression for torque required to raise the load in power screws. (08 Marks)
- b. Enumerate four typical applications of knuckle joint. (02 Marks)
- c. A machine weighing 20 kN is to be raised by a single start square threaded screw rod of 50mm diameter, 8mm pitch screw jack at a maximum speed of 6 m/minute. If the coefficient of friction for threads is 0.2, determine the power required to raise (lift) the machine. The inside and outside diameters of the thrust collar are 30 and 60mm respectively. The coefficient of friction for collar is 0.1. (10 Marks)

SMRIT LIBRARY
BANGALORE - 560 037

