

USN	1 C R 1		ME			
-----	---------	--	----	--	--	--

Scheme of evaluation

Sub:	Fluid Power Engineering					Sub Code:	18ME55	Branch:	ME		
Date:	24/01/2022	Duration:	90 min's	Max Marks:	50	Sem / Sec:	5 th A & B			OBE	
<u>Answer any 5 Questions.</u>								MARKS	CO	RBT	
1.	Classify Hydraulic control valves. Explain with a neat sketch, the working of check valve and draw its graphical symbol.						4+4+2	CO3	L1		
2.	Explain with a neat sketch how a four-way direction control valves operate. Draw graphical symbol.						4+4+2	CO3	L2		
3.	Explain the working of a simple pressure relief valve with a neat diagram. Show the graphical symbol also.						4+4+2	CO3	L2		
4.	Write the symbolic representation of actuation system: i)Push button ii)Spring iii)Lever iv)Solenoid v)Mechanical						2*5	CO3	L2		
5.	Design a hydraulic sequencing circuit used in a drilling machine for clamping work piece and drilling a hole.						6+4	CO3	L4		
6.	Explain briefly the principle involved in regenerative circuit and obtain an expression for the speed of actuator.						5+3+2	CO3	L4		
7.	With a neat sketch, explain any three types of center flow path configuration for three position four way valves with graphical symbols.						(3*3)+1	CO3	L3		

CI

CCI

HOD

Solution

1. The control of hydraulic power in hydraulic power systems is carried out by means of control valves. The control requirements are imposed by the function of the system. The parameters of the mechanical power delivered to the load are managed hydraulically by controlling the direction, pressure, and flow rate. It is important to know the primary function and operation of the various types of control components.

The selection of these control components not only involves the type, but also the size, the actuating method and remote control capability. There are 3 basic types of valves.

1. Directional control valves (DCV)
1. Pressure control valves (PCV)
2. Flow control valves. (FCV)

Directional control valves are essentially used for distribution of energy in a fluid power system. They establish the path through which a fluid traverses a given circuit. For example they control the direction of motion of a hydraulic cylinder or motor. These valves are used to control the start, stop and change in the direction of flow of pressurized fluid.

Pressure may gradually build up due to decrease in fluid demand or due to sudden surge as valves opens or closes. Pressure control valves protect the system against such overpressure. Pressure relief valve, pressure reducing, sequence, unloading and counterbalance valve are different types of pressure control valves.

In addition, fluid flow rate must be controlled in various lines of a hydraulic circuit. For example, the control of actuator speeds depends on flow rates. This type of control is accomplished through the use of flow control valves. For example shock absorbers are designed to smooth out pressure surges and to dampen hydraulic shock.

Check Valve : 2/2 DCV (Poppet design)



Fig 3.1 2/2 DCV (Poppet Design)

Figure 3.1 a. Shows a ball poppet type 2 / 2 DCV. It is essentially a check valve as it allows free flow of fluid only in one direction (P to A) as the valve is opened hydraulically and hence the pump Port P is connected to port A as shown in fig3.1 b. In the other direction the valve is closed by the ball poppet and hence the flow from the port A is blocked. A poppet is a specially shaped plug element held onto a seat by a spring. Fluid flows through the valve in the space between the seat and poppet. As shown, light spring holds the poppet in the closed position. In the free-flow direction, the fluid pressure overcomes the spring force at about 35kPa.

If flow is attempted in the opposite direction, the fluid pressure pushes the poppet along with the spring force in the closed position. Therefore no flow is permitted. The higher the pressure, the greater will be the force pushing the poppet against the seat. Thus, increased pressure will not result in any tendency to allow flow in the no flow direction. The symbol for this type of design is same as that of check valve. (Fig 3.2)

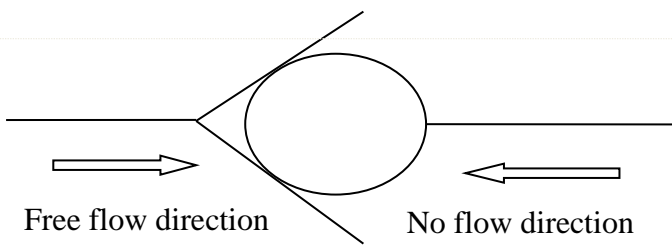
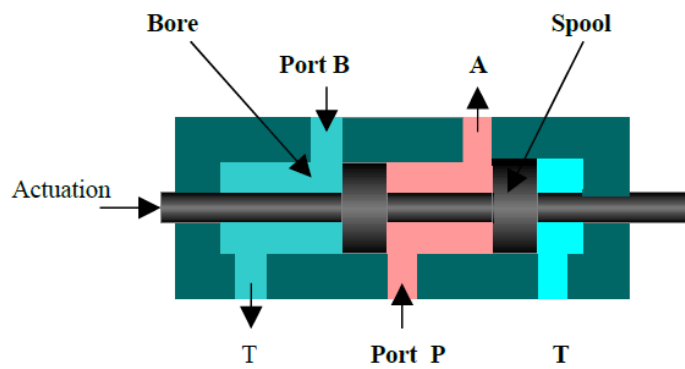

Fig 3.2 Symbol of 2/2 poppet valve (Check valve)

2. Four - way DCV: -

These valves are also used to operate double acting cylinder. These valves are also called as impulse valve as 2 / 4 DCV has only two switching positions, i.e. it has no mid position. These valves are used to reciprocate or hold and actuating cylinder in one position. They are used on machines where fast reciprocation cycles are needed. Since the valve actuator moves such a short distance to operate the valve from one position to the other, this design is used for punching, stamping and for other machines needing fast action. Fig 43.6 a and b shows the two position of 2 / 4 DCV.



3.6 a) 1 Position : P to A and B to T

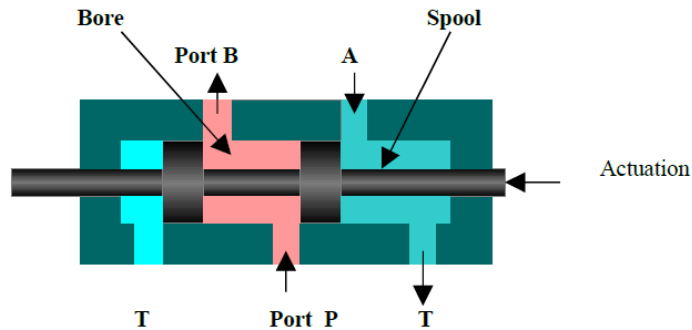

3.6 b) 2 Positon, P to B and A to T

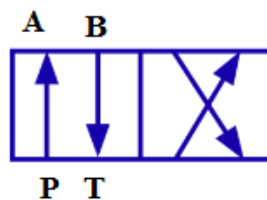

Figure 3.6 c Graphical symbol for 4/2 DCV

These valves are available with a choice of actuation, manual, mechanical, solenoid, pilot & pneumatic. Four-way valve comes with two or three position. One should note that the graphical symbol of the valve shows only one tank port even though the physical design may have two as it is only concerned with the function.

3. Pressure-Relief Valves

The pressure relief valves are used to protect the hydraulic components from excessive pressure. This is one of the most important components of a hydraulic system and is essentially required for safe operation of the system. Its primary function is to limit the system pressure within a specified range. It is similar to a fuse in

an electrical system. Pressure relief valve is normally a closed type and it opens when the pressure exceeds a specified maximum value by diverting pump flow back to the tank. The simplest type valve contains a poppet held in a seat against the spring force as shown in **Figure 3.13**. The fluid enters from the opposite side of the poppet. When the system pressure exceeds the preset value, the poppet lifts and the fluid is escaped through the orifice to the storage tank directly. It reduces the system pressure and as the pressure reduces to the set limit again the valve closes.

Schematic of direct pressure relief valve is shown in **figure 3.13**. This type of valves has two ports; one of which is connected to the pump and another is connected to the tank. It consists of a spring chamber where poppet is placed with a spring force. Generally, the spring is adjustable to set the maximum pressure limit of the system. The poppet is held in position by combined effect of spring force and dead weight of spool. As the pressure exceeds this combined force, the poppet raises and excess fluid bypassed to the reservoir (tank). The poppet again reseats as the pressure drops below the pre-set value.

Note the external adjusting screw, which varies spring force and, thus, the pressure at which the valve begins to open (cracking pressure) (Fig. 1.3). It should be noted that the poppet must open sufficiently to allow full pump flow. The pressure that exists at full pump flow can be substantially greater than cracking pressure. The pressure at full pump flow is the pressure level that is specified when referring to the pressure setting of the valve. It is the maximum pressure level permitted by the relief valve.

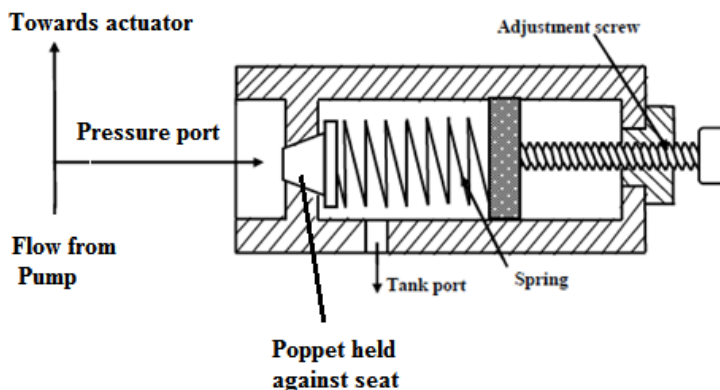

Figure 3.13 Simple pressure relief valve

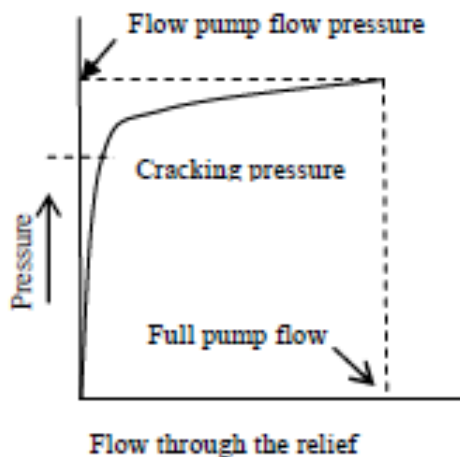
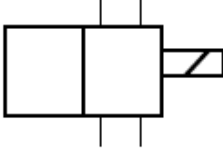
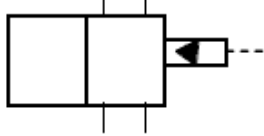
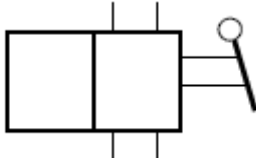
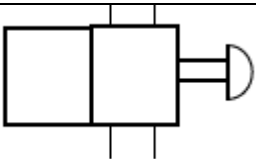
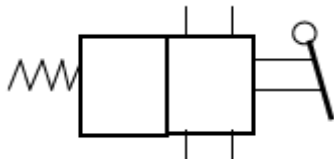
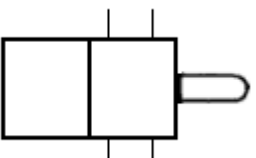

Figure 3.15 Characteristics of a relief valve

If the hydraulic system does not accept any flow, then all the pump flow must return to the tank via the relief valve. The pressure-relief valve provides protection against any overloads experienced by the actuators in the hydraulic system. Of course, a relief valve is not needed if a pressure-compensated vane pump is used. Obviously one important function of a pressure-relief valve is to limit the force or torque produced by hydraulic cylinders or motors.

4. Actuating Devices

Direction control valves may be actuated by a variety of methods. Actuation is the method of moving the valve element from one position to another. There are four basic methods of actuation: Manual, mechanical, solenoid-operated and pilot-operated. Several combinations of actuation are possible using these four basic methods. Graphical symbols of such combinations are given in Table 3.2.

	Solenoid actuated
	Pilot actuated
	Manual operated (Lever)
	Push button operated
	Spring return
	Mechanical plunger

5. Sequencing circuit

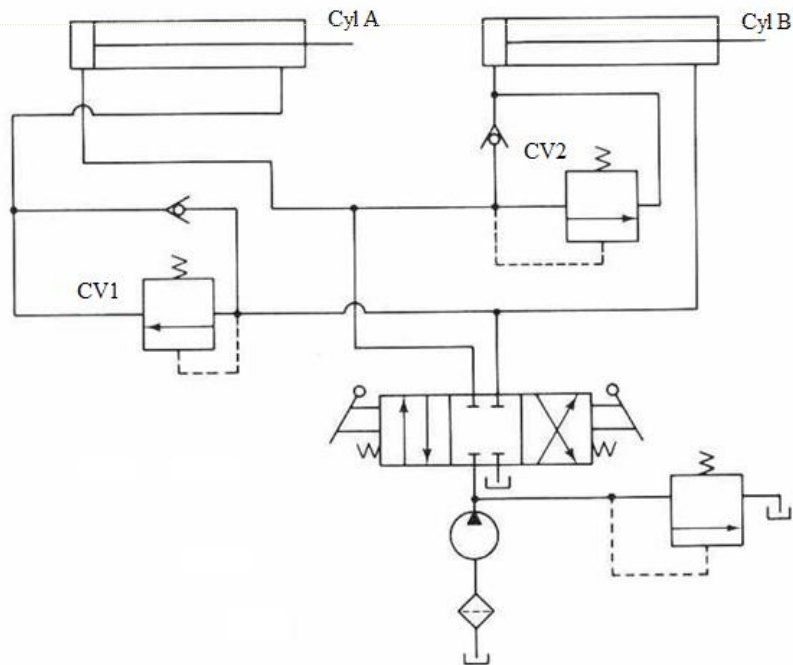

Figure 4.8 Sequencing circuit.

In many applications, it is necessary to perform operations in a definite order. Hydraulic cylinders can be operated sequentially using a sequence valve. Figure 1.7 shows that two sequence valves are used to sequence the operation of two double-acting cylinders. This sequence of cylinder operation is controlled by sequence valves. This hydraulic circuit can be used in a production operation such as drilling. Cylinder A is used as a clamp cylinder and cylinder B as a drill cylinder. Cylinder A extends and clamps a work piece. Then cylinder B extends to drive a spindle to drill a hole. Cylinder B retracts the drill spindle and then cylinder A retracts to release the work piece for removal.

The sequence of operation realized by the circuit shown in Figure 4.8 is:

Step A – Extend Cylinder A (To clamp the work piece)

Step B – Extend Cylinder B while holding pressure on Cylinder A (To perform drilling operation)

Step C – Retract Cylinder B (To retract the spindle after drilling)

Step D – Retract Cylinder A (To unclamp the work piece)

When the DCV is shifted into its left envelope mode, the cylinder A extends completely. When the pressure reaches the pressure setting of sequence valve (SV1), the valve opens and fluid flow is allowed to the cylinder B as a result cylinder B extends. If the DCV is then shifted into its right envelope mode cylinder B retracts fully, and then the cylinder A retracts. Hence this sequence of cylinder operation is controlled by the sequence valves. The spring centered position of the DCV locks both cylinders in place.

6. Regenerative Cylinder Circuit

Figure 4.3 shows a regenerative circuit that is used to speed up the extending speed of a double-acting cylinder. The pipelines to both ends of the hydraulic cylinder are connected in parallel and one of the ports of the 4/3 valve is blocked by simply screwing a thread plug into the port opening. During retraction stroke, the 4/3 valve is configured to the right envelope. During this stroke, the pump flow bypasses the DCV and enters the rod end of the cylinder. Oil from the blank end then drains back to the tank through the DCV. When the DCV is shifted in to its left-envelope configuration, the cylinder extends as shown in Fig. 1.3. The speed of extension is greater than that for a regular double-acting cylinder because the flow from the rod end regenerates with the pump flow Q_P to provide a total flow rate Q_T .

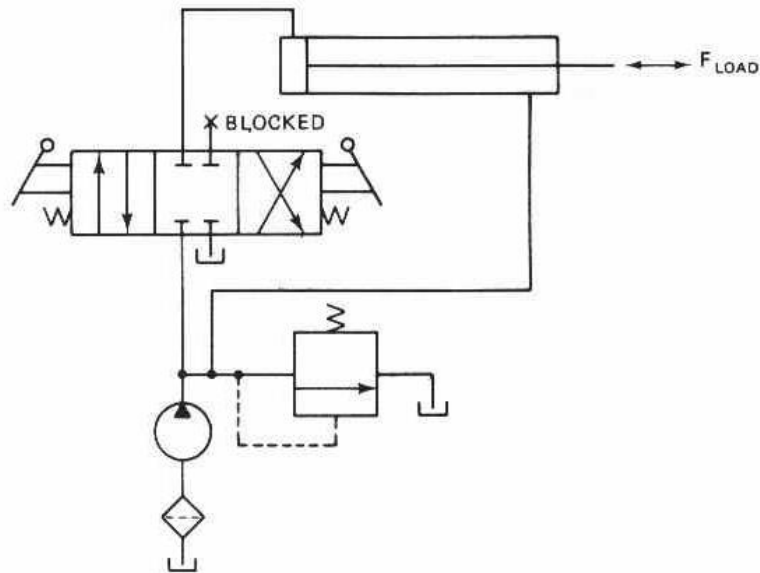

Figure 4.3 Regenerative circuit.

Expression for the Cylinder Extending Speed

The total flow rate Q_T entering the blank end of the cylinder is given by

$$Q_T = Q_P + Q_r$$

Where Q_P is the pump flow rate and is Q_r the regenerative flow or flow from the rod end.

Hence, Pump flow rate,

$$= Q_P = Q_T - Q_r$$

But the total flow rate acting on the blank rod end is given by

$$Q_P = A_P V_{\text{ext}}$$

Similarly, the flow rate from the rod end is given by

$$Q_r = (A_P - A_r) V_{\text{ext}}$$

So pump flow rate is

$$Q_P = A_P V_{\text{ext}} - (A_P - A_r) V_{\text{ext}}$$

$$Q_P = A_r V_{\text{ext}}$$

The extending speed of the piston is given as

$$V_{\text{ext}} = Q_P / A_r$$

Thus, a small area provides a large extending speed. The extending speed can be greater than the retracting speed if the rod area is made smaller. The retraction speed is given by

$$V_{\text{ret}} = Q_P / A_P - A_r$$

The ratio of extending and retracting speed is given as

$$V_{\text{ext}} / V_{\text{ret}} = Q_P / A_r / Q_P / A_P - A_r$$

$$= A_P - A_r / A_r$$

$$= (A_P / A_r) - 1$$

When the piston area equals two times the rod area, the extension and retraction speeds are equal. In general, the greater the ratio of the piston area to rod area, the greater is the ratio of the extending speed to retraction speed.

Load-Carrying Capacity during Extension

The load-carrying capacity of a regenerative cylinder during extension is less than that obtained from a regular double-acting cylinder. The load-carrying capacity $F_{\text{load-extension}}$ for a regenerative cylinder during extension equals pressure times the piston rod area. This is because system pressure acts on both sides of the piston during extension. Then

$$F_{\text{load-extension}} = p A_r$$

Thus, we do not obtain more power from the regenerative cylinder during extension because the extension speed is increased at the expense of reduced load-carrying capacity.

7. **Three- position, four- way DCV** have different variety of center configurations. The common varieties are the open center, closed center, tandem center, floating center, & regenerative center with open, closed and tandem are the three basic types A variety of center configurations provides greater flexibility for circuit design.

