

Solution for IAT2

1. Define impulse wave. Discuss how impulse wave is generated in laboratory with a neat diagram of Marx generator.

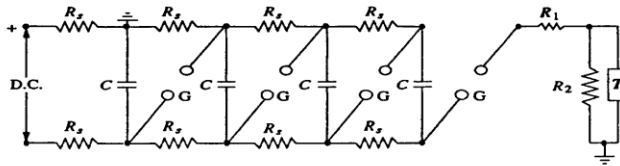
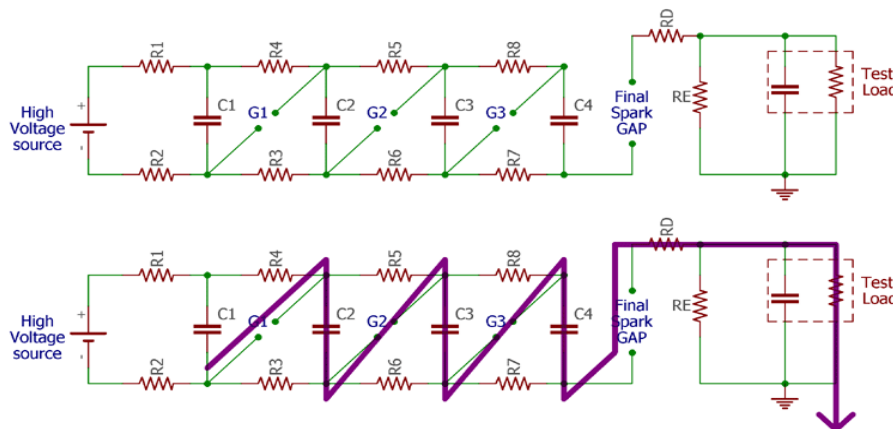

Fig. 6.17a Schematic diagram of Marx circuit arrangement for multistage impulse generator

- C — Capacitance of the generator
- R_s — Charging resistors
- G — Spark gap
- R_1, R_2 — Wave shaping resistors
- T — Test object



Impulse Voltage Generator

- ⦿ The generator capacitance C_1 is to be first charged and then discharged into the wave shaping circuits.
- ⦿ A single capacitor C_1 may be used for voltages up to 200 kV.
- ⦿ Beyond this voltage, a single capacitor and its charging unit may be too costly, size becomes very large.
- ⦿ The cost and size of the impulse generator increases at a rate of the **square or cube** of the **voltage rating**.
- ⦿ Producing very **high voltages**, a bank of capacitors are **charged in parallel** and then **discharged in series**.
- ⦿ The arrangement for charging the capacitors in parallel and then connecting them in series for discharging was originally proposed by **Marx**.

- ⊙ **Modified Marx circuits** are used for the multistage impulse generators.

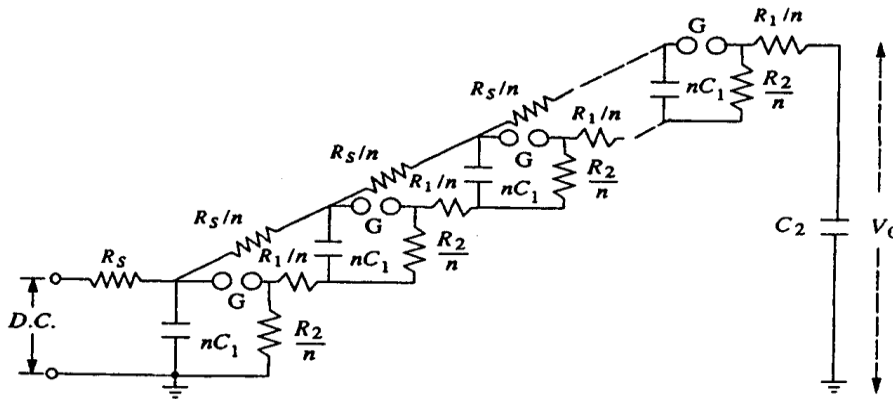

Fig. 6.17b Multistage impulse generator incorporating the series and wave tail resistances within the generator

- ⊙ The schematic diagram of Marx circuit and its modification are shown in Figs. 6.17a and 6.17b, respectively.
- ⊙ Usually the charging resistance is chosen to limit the charging current to about 50 to 100 mA, and the generator capacitance C is chosen such that the product CR is about 10 s to 1 min.
- ⊙ The gap spacing is chosen such that the breakdown voltage of the gap G is greater than the charging voltage V .
- ⊙ All the capacitances are charged to the voltage V in about 1 minute.
- ⊙ When the impulse generator is to be discharged, the gaps G are made to spark over simultaneously by some external means.
- ⊙ All the capacitors C get connected in series and discharge into the load capacitance or the test object
- ⊙ The discharge time constant CR_1/n (for n stages) will be very very small (microseconds), compared to the charging time constant CR which will be few seconds.
- ⊙ Hence, no discharge takes place through the charging resistors R_s .
- ⊙ In the Marx circuit is of Fig. 6.17a the impulse wave shaping circuit is connected externally to the capacitor unit In Fig. b,
- ⊙ The modified Marx circuit is shown, wherein the resistances R_1 and R_2 are incorporated inside the unit.

------(10 Marks)

2. Cockroft Walton Voltage Multiplier Circuit

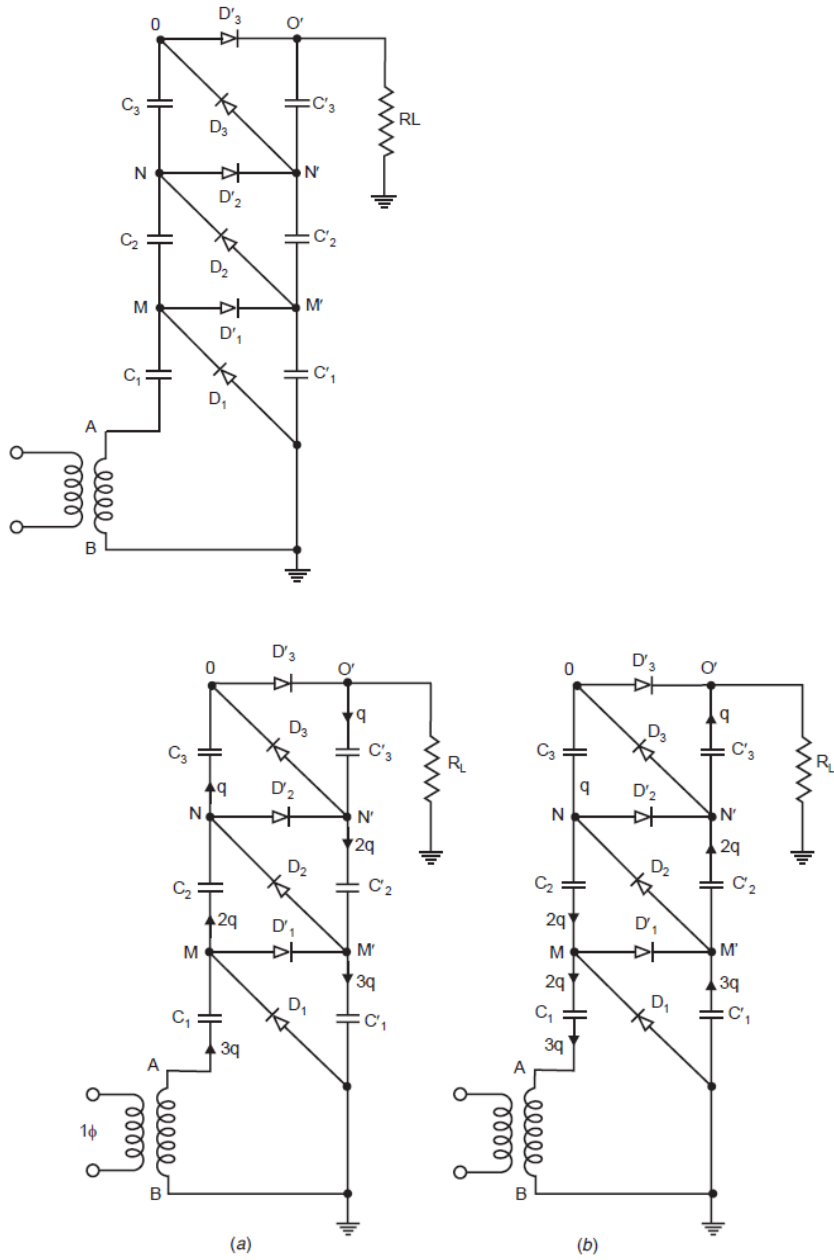

Fig. 2.4 (a) Charging of smoothing Column (b) Charging of oscillating column

During the transfer cycle shown in Fig. 2.4 (b), the diodes D_1, D_2, D_3 , conduct when B is positive with reference to A . Here C_2 transfers q charge to C_3 , C_1 transfers charge $2q$ to C_2 and the transformer provides charge $3q$.

For n -stage circuit, the total ripple will be

$$2\delta V = \frac{I}{f} \left(\frac{1}{C'_n} + \frac{2}{C'_{n-1}} + \frac{3}{C'_{n-2}} + \dots + \frac{n}{C'_1} \right)$$

or

$$\delta V = \frac{I}{2f} \left(\frac{1}{C'_n} + \frac{2}{C'_{n-1}} + \frac{3}{C'_{n-2}} + \dots + \frac{n}{C'_1} \right) \quad (2.7)$$

From equation (2.7), it is clear that in a multistage circuit the lowest capacitors are responsible for most ripple and it is, therefore, desirable to increase the capacitance in the lower stages. However, this is objectionable from the view point of High Voltage Circuit where if the load is large and the load voltage goes down, the smaller capacitors (within the column) would be overstressed. Therefore, capacitors of equal value are used in practical circuits *i.e.*, $C_n = C_{n-1} = \dots = C_1 = C$ and the ripple is given as

$$\delta V = \frac{I}{2fC} \frac{n(n+1)}{2} = \frac{In(n+1)}{4fC} \quad (2.8)$$

The second quantity to be evaluated is the voltage drop ΔV which is the difference between the theoretical no load voltage $2nV_{max}$ and the onload voltage. In order to obtain the voltage drop ΔV refer to Fig. 2.4 (a).

Here C_1 is not charged upto full voltage $2V_{max}$ but only to $2V_{max} - 3q/C$ because of the charge given up through C_1 in one cycle which gives a voltage drop of $3q/C = 3I/fC$

The voltage drop in the transformer is assumed to be negligible. Thus, C_2 is charged to the voltage

$$\left(2V_{max} - \frac{3I}{fC} \right) - \frac{3I}{fC}$$

since the reduction in voltage across C_3 again is $3I/fC$. Therefore, C_2 attains the voltage

$$2V_{max} - \left(\frac{3I + 3I + 2I}{fC} \right)$$

In a three stage generator

$$\Delta V_1 = \frac{3I}{fC}$$

$$\Delta V_2 = \{2 \times 3 + (3-1)\} \frac{I}{fC}$$

$$\Delta V_3 = (2 \times 3 + 2 \times 2 + 1) \frac{I}{fC}$$

In general for a n -stage generator

$$\Delta V_n = \frac{nI}{fC}$$

$$\Delta V_{n-1} = \frac{I}{fC} \{2n + (n-1)\}$$

$$\Delta V_{n-2} = \frac{I}{fC} \{2n + 2(n-1) + (n-2)\}$$

$$\vdots$$

$$\Delta V_1 = \frac{I}{fC} \{2n + 2(n-1) + 2(n-2) + \dots + 2 \times 3 + 2 \times 2 + 1\}$$

$$\Delta V = \Delta V_n + \Delta V_{n-1} + \dots + \Delta V_1$$

After omitting I/fC , the series can be rewritten as:

$$T_n = n$$

$$T_{n-1} = 2n + (n-1)$$

$$T_{n-2} = 2n + 2(n-1) + (n-2)$$

$$T_{n-3} = 2n + 2(n-1) + 2(n-2) + (n-3)$$

$$\vdots$$

$$T_1 = 2n + 2(n-1) + 2(n-2) + \dots + 2 \times 3 + 2 \times 2 + 1$$

$$T = T_n + T_{n-1} + T_{n-2} + \dots + T_1$$

To sum up we add the last term of all the terms (T_n through T_1) and again add the last term of the remaining term and so on, *i.e.*,

$$\begin{aligned} & [n + (n-1) + (n-2) + \dots + 2 + 1] \\ & + [2n + 2(n-1) + 2(n-2) + \dots + 2 \times 2] \\ & + [2n + 2(n-1) + \dots + 2 \times 4 + 2 \times 3] \\ & + [2n + 2(n-1) + \dots + 2 \times 4] \\ & + [2n + 2(n-1) + 2(n-2) + \dots + 2 \times 5] + \dots [2n] \end{aligned}$$

Rearranging the above terms we have

$$\begin{aligned} & n + (n-1) + (n-2) + \dots + 2 + 1 \\ & + [2n + 2(n-1) + 2(n-2) + \dots + 2 \times 2 + 2 \times 1] - 2 \times 1 \\ & + [2n + 2(n-1) + 2(n-2) + \dots + 2 \times 3 + 2 \times 2 + 2 \times 1] - 2 \times 2 - 2 \times 1 \\ & + [2n + 2(n-1) + 2(n-2) + \dots + 2 \times 4 + 2 \times 3 + 2 \times 2 + 2 \times 1] \\ & - 2 \times 3 - 2 \times 2 - 2 \times 1 \\ & \dots \\ & [2 \times n + 2(n-1) + \dots + 2 \times 2 + 2 \times 1] - [2(n-1)] \\ & + 2(n-2) + \dots + 2 \times 2 + 2 \times 1 \end{aligned}$$

or $n + (n-1) + (n-2) + \dots + 2 + 1$
 Plus $(n-1)$ number of terms of $2[n + (n-1) + \dots + 2 + 1]$
 minus $2[1 + (1+2) + (1+2+3) + \dots + \dots \{1+2+3 + \dots (n-1)\}]$

The last term (minus term) is rewritten as

$$\begin{aligned} & 2[1 + (1+2) + \dots + \{1+2+3 + \dots (n-1)\} + \{1+2 + \dots + n\}] \\ & - 2[1 + 2 + 3 + \dots + n] \end{aligned}$$

The n th term of the first part of the above series is given as

$$t_n = \frac{2n(n+1)}{2} = (n^2 + n)$$

Therefore, the above terms are equal to

$$\begin{aligned} & = \sum (n^2 + n) - 2 \sum n \\ & = \sum (n^2 - n) \end{aligned}$$

Taking once again all the term we have

$$\begin{aligned} T & = \sum n + 2(n-1) \sum n - \sum (n^2 - n) \\ & = 2n \sum n - \sum n^2 \\ & = 2n \cdot \frac{n(n+1)}{2} - \frac{n(n+1)(2n+1)}{6} \\ & = \frac{6(n^3 + n^2) - n(2n^2 + 3n + 1)}{6} \\ & = \frac{6n^3 + 6n^2 - 2n^3 - 3n^2 - n}{6} \\ & = \frac{4n^3 + 3n^2 - n}{6} = \frac{2}{3}n^3 + \frac{n^2}{2} - \frac{n}{6} \end{aligned} \tag{2.9}$$

Here again the lowest capacitors contribute most to the voltage drop ΔV and so it is advantageous to increase their capacitance in suitable steps. However, only a doubling of C_1 is convenient as this capacitors has to withstand only half of the voltage of other capacitors. Therefore, ΔV_1 decreases by an amount nI/fC which reduces ΔV of every stage by the same amount *i.e.*, by

$$n \cdot \frac{nI}{2fC}$$

$$\text{Hence } \Delta V = \frac{I}{fC} \left(\frac{2}{3}n^3 - \frac{n}{6} \right) \tag{2.10}$$

If $n \geq 4$ we find that the linear term can be neglected and, therefore, the voltage drop can be approximated to

$$\Delta V = \frac{I}{fC} \cdot \frac{2}{3}n^3 \tag{2.11}$$

The maximum output voltage is given by

$$V_{0\max} = 2nV_{\max} - \frac{I}{fC} \cdot \frac{2}{3}n^3 \quad (2.12)$$

From (2.12) it is clear that for a given number of stages, a given frequency and capacitance of each stage, the output voltage decrease linearly with load current I . For a given load, however, $V_0 = (V_{0\max} - V)$ may rise initially with the number of stages n , and reaches a maximum value but decays beyond on optimum number of stage. The optimum number of stages assuming a constant V_{\max} , I , f and C can be obtained for maximum value of $V_{0\max}$ by differentiating equation (2.12) with respect to n and equating it to zero.

$$\begin{aligned} \frac{dV_{\max}}{dn} &= 2V_{\max} - \frac{2}{3} \frac{I}{fC} 3n^2 = 0 \\ &= V_{\max} - \frac{I}{fC} n^2 = 0 \end{aligned}$$

or
$$n_{opt} = \sqrt{\frac{V_{\max} fC}{I}} \quad (2.13)$$

Substituting n_{opt} in equation (2.12) we have

$$\begin{aligned} (V_{0\max})_{max} &= \sqrt{\frac{V_{\max} fC}{I}} \left(2V_{\max} - \frac{2I}{3fC} \frac{V_{\max} fC}{I} \right) \\ &= \sqrt{\frac{V_{\max} fC}{I}} \left(2V_{\max} - \frac{2}{3} V_{\max} \right) \\ &= \sqrt{\frac{V_{\max} fC}{I}} \cdot \frac{4}{3} V_{\max} \end{aligned} \quad (2.14)$$

It is to be noted that in general it is more economical to use high frequency and smaller value of capacitance to reduce the ripples or the voltage drop rather than low frequency and high capacitance.

------(10 Marks)

Module 2
Generation of High DC and AC voltages
(problems)

1) A 10 stage Cockroft Walton circuit has all capacitors of $0.06\mu\text{F}$. The secondary voltage of the supply transformer is 100KV at a frequency of 150Hz . If the load current is 1mA , determine

(a) voltage regulation

(b) ripple

(c) the optimum number of stages for maximum output voltage

(d) the maximum output voltage.

Capacitance, $C = 0.06\mu\text{F}$

Load current, $I = 1\text{mA}$

Frequency, $f = 150\text{Hz}$

No. of stages, $n = 10$

Secondary voltage of supply transformer
 $= 100\text{KV}$

Module 2
Generation of High DC and AC voltages
(problems)

1) A 10 stage Cockroft Walton circuit has all capacitors of $0.06\mu\text{F}$. The secondary voltage of the supply transformer is 100KV at a frequency of 150Hz . If the load current is 1mA , determine

(a) voltage regulation

(b) ripple

(c) the optimum number of stages for maximum output voltage

(d) the maximum output voltage.

Capacitance, $C = 0.06\mu\text{F}$

Load current, $I = 1\text{mA}$

Frequency, $f = 150\text{Hz}$

No. of stages, $n = 10$

Secondary voltage of supply transformer
 $= 100\text{KV}$

(a) Voltage drop, $V = \frac{I}{fC} \left[\frac{2}{3} n^3 + \frac{n^2}{2} - \frac{n}{6} \right]$

If $n \geq 4$, the linear term can be neglected.

$$\therefore V = \frac{I}{fC} \left[\frac{2}{3} n^3 + \frac{n^2}{2} \right]$$
$$= \frac{1 \times 10^3}{150 \times 0.06 \times 10^{-6}} \left[\frac{2}{3} \times 10^3 + \frac{10^2}{2} \right]$$

$$= 111.111 \left[666.67 + 50 \right]$$

$$= \underline{\underline{79.629 \text{ kV}}}$$

$$\therefore \% \text{ Voltage regulation} = \frac{79.629 \times 100}{2nV_{\text{max}}}$$

$$= \frac{79.629 \times 100}{2 \times 10 \times 100}$$

$$= \underline{\underline{3.98\%}}$$

(b) Ripple voltage, $\Delta V = \frac{I}{fC} \frac{n(n+1)}{2}$

$$= \frac{1 \times 10^{-3} \times 10 \times (10+1)}{150 \times 0.06 \times 10^{-6} \times 2}$$

$$= \underline{\underline{6.1 \text{ kV}}}$$

$$\% \text{ ripple} = \frac{6.1 \times 10^2}{2 \text{ m } V_{\text{max}}} = \frac{6.1 \times 100}{2 \times 10 \times 100}$$

$$= \underline{\underline{0.305\%}}$$

(c) Optimum number of stages,

$$n_{\text{opt}} = \sqrt{\frac{V_{\text{max}} f C}{I}}$$

$$= \sqrt{\frac{100 \times 150 \times 0.06 \times 10^{-6} \times 10^3}{1 \times 10^{-3}}}$$

$$= \underline{\underline{30}}$$

(d) Maximum output voltage, $(V_{\text{max}})_{\text{max}}$

$$= \sqrt{\frac{V_{\text{max}} f C}{I}} \cdot \frac{4}{3} V_{\text{max}}$$
$$= 30 \times \frac{4}{3} \times 100 = \underline{\underline{4000 \text{ KV}}}$$

2) A Tesla coil has a primary winding rated for 10kV. If L_1, L_2 and coefficient of coupling K are 10mH, 200mH and 0.6 respectively, Find the peak value of the output voltage if the capacitance in the primary side is $2.0 \mu\text{F}$ and that on the secondary side is 1nF . Neglect the winding resistance. Also find the highest resonant frequency produced with rated voltage applied.

Rated primary voltage, $V = 10\text{KV}$

$L_1 = 10\text{mH} =$ leakage inductance of primary

$L_2 = 200\text{mH} =$ Leakage inductance of secondary

Coefficient of coupling, $K = 0.6$

Capacitance of the primary side, $C_1 = 2\mu\text{F}$

5. Electrical Tests on Insulator

The tests are as (i) type tests, and (ii) the routine tests.

- Type tests to prove or check the design features and the quality.
- The routine tests to check the quality of the individual test piece.
- Type tests are done on samples when new designs or design changes are introduced,
- The routine tests are done to ensure the reliability of the individual test objects and quality and consistency of the materials used in their manufacture.

High voltage tests include

- (i) the power frequency tests,
- (ii) impulse tests.

All the insulators are tested for both categories of test.

Power frequency tests

(a) Dry and Wet Flashover Tests :

- In these tests the a.c. voltage of power frequency is applied across the insulator and increased at a uniform rate of about 2 per cent per second of 75% of the estimated test voltage, to such a value that a breakdown occurs along the surface of the insulator.
- If the test is conducted under normal conditions without any rain or precipitation, it is called "dry flashover test".
- If the test is done under conditions of rain, it is called "wet flashover test"

Wet and Dry Withstand Tests (One Minute):

- In these tests, the voltage specified in the relevant specification is applied under dry or wet conditions for a period of one minute with an insulator mounted as in service conditions.
- The test piece should withstand the specified voltage.

a) Impulse Withstand Voltage Test :

- This test is done by applying standard impulse voltage of specified value under dry conditions with both positive and negative polarities of the wave.
- If five consecutive waves do not cause a flashover or puncture, the insulator is deemed to have passed the test.

- If two applications cause flashover, the object is deemed to have failed.
- If there is only one failure, additional ten applications of the voltage wave are made.
- If the test object has withstood the subsequent applications, it is said to have passed the test.

b)Impulse Flashover Test

- The test is done as above with the specified voltage.
- Usually, the probability of failure is determined for 40% and 60% failure values or 20% and 80% failure values, since it is difficult to adjust the test voltage for the exact 50% flashover values.
- The average value of the upper and the lower limits is taken.
- The insulator surface should not be damaged by these tests, but slight marking on its surface or chipping off of the cement is allowed.

c)Pollution Testing

Because of the problem of pollution of outdoor electrical insulation and consequent problems of the maintenance of electrical power systems, pollution testing is gaining importance.

------(10 Marks)

5. Testing on Power Transformers

- Transformers are very important and costly apparatus in power systems.
- Great care has to be exercised to see that the transformers are not damaged due to transient over voltages of either lightning or power frequency.
- Hence, overvoltage tests become very important in the testing of transformers.

Induced Over voltage Test

- Transformers are tested for over voltages by exciting the secondary of the transformer from a high frequency a.c. source (100 to 400 Hz) to about twice the rated voltage.

- This reduces the core saturation and also limits the charging current necessary in large power transformers.
- The insulation withstand strength can also be checked.

Partial Discharge Test

- Partial discharge tests on the windings are done to assess the discharge magnitudes and the radio interference levels .
- The transformer is connected in a manner similar to any other equipment and the discharge measurements are made.
- The location of the fault or void is sometimes done by using the travelling wave technique similar to that for cables.
- So far, no method has been standardized as to where the discharge is to be measured.
- Multi-terminal partial discharge measurements are recommended.
- Under the application of power frequency voltage, the discharge magnitudes greater than 10^4 pico coulomb are considered to be severe, and the transformer insulation should be such that the discharge magnitude will be far below this value.

Impulse Testing of Transformers

- The purpose of the impulse tests is to determine the ability of the insulation of the transformers to withstand the transient voltages due to lightning, etc.
- Since the transients are impulses of short rise time, the voltage distribution along the transformer winding will not be uniform.
- The equivalent circuit of a transformer winding for impulses is shown in Fig.
- If an impulse wave is applied to such a network the voltage distribution along the element will be uneven, and oscillations will be set in producing voltages much higher than applied voltage.

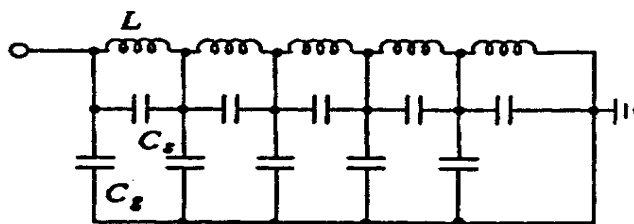

L — Inductance (series)
 C_s — Series capacitance
 C_g — Shunt capacitance to ground

- Impulse testing of transformers is done using both the full wave and the chopped wave of the standard impulse, produced by a rod gap with a chopping time of 3 to 6 μ s.
- To prevent large over voltages being induced in the windings not under test, they are short circuited and connected to ground.
- But the short circuiting reduces the impedance of the transformer and hence poses problems in adjusting the standard waveshape of the impulse generators.
- It also reduces the sensitivity of detection.

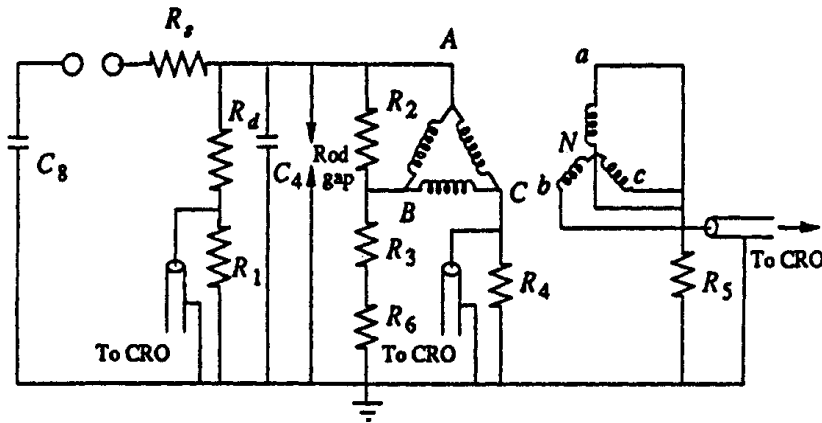

Impulse testing is done in the following sequence:

- (i) applying impulse voltage of magnitude 75% of the Basic Impulse Level (BIL) of the transformer under test,
- (ii) one full wave ovltague of 100% BIL,
- (iii) two chopped waves of 100% BIL,
- (iv) one full wave of 100% BIL, and
- (v) one full wave of 75% BIL.

It is very important to see that the grounding is proper and the windings not under test :

------(10 Marks)

6(a)

needed to produce $1.2/50 \mu s$ impulse wave. What is the maximum output voltage of the generator, if the charging voltage is 120 kV ?

Assume the equivalent circuit of the impulse generator to be as shown in fig (b)

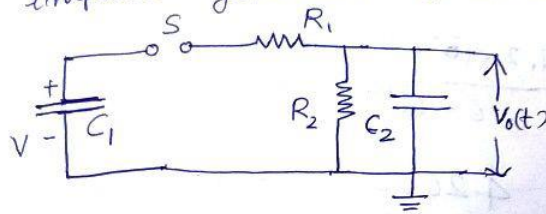

Fig (b)

Equivalent circuit of impulse generator

Generator capacitance, $C_1 = \frac{C}{n} = \frac{0.16 \times 10^{-6}}{8}$
 $= \underline{\underline{0.02 \mu F}}$

Number of stages, $n = 8$

Load capacitance, $C_2 = 1000 \text{ pF} = 0.001 \mu F$

Impulse wave produced is $1.2/50 \mu s$ wave

\therefore The time to front, $t_f = 1.2 \mu s = 3.0 R_1 C_2$

$$\therefore 1.2 \times 10^{-6} = 3 \times R_1 \times C_2$$

Charging voltage $= 120 \text{ kV}$

$$1.2 \times 10^{-6} = 3 R_1 \times \frac{0.02 \times 10^{-6} \times 1000 \times 10^{12}}{(0.02 + 0.001) \times 10^{-6}}$$

$$= \frac{6 \times 10^{17} R_1}{0.021 \times 10^{-6}}$$

$$\therefore R_1 = \frac{1.2 \times 10^{-6} \times 0.021 \times 10^6}{6 \times 10^{17}}$$

$$\therefore R_1 = \underline{\underline{420 \Omega}} = \text{series-resistance}$$

The time to tail, $t_2 = 50 \mu\text{s}$

$$\therefore t_2 = 50 \times 10^{-6} = 0.7 (R_1 + R_2) (C_1 + C_2)$$

$$\therefore R_1 + R_2 = \frac{50 \times 10^{-6}}{0.7 (0.021 \times 10^{-6})}$$

$$= \frac{50 \times 10^{-6}}{1.47 \times 10^{-8}} = 3401.36$$

$$\therefore R_2 = 3401.36 - R_1$$

$$= 3401.36 - 420$$

$$\therefore R_2 = \underline{\underline{2981.36 \Omega}} = \text{damping resistance}$$

The dc charging voltage for 8 steps,

$$V = 8 \times \text{Charging voltage} \\ = 8 \times 120 \text{ kV} = \underline{\underline{960 \text{ kV}}}$$

The maximum output voltage is

$$V_0(t) = \frac{V}{R_1 C_2 (\alpha - \beta)} (e^{-\alpha t} - e^{-\beta t})$$

(For fig (b))

$$\therefore V_0(t) = \frac{960 \times 10^3}{420 \times 0.001 \mu\text{F} (\alpha - \beta)} [e^{-\alpha t} - e^{-\beta t}]$$

$$\text{Here } \alpha = \frac{1}{R_1 C_2} = \frac{1}{420 \times 0.001 \mu\text{F}} = \underline{\underline{2.38 \times 10^6}}$$

$$\beta = \frac{1}{R_2 C_1} = \frac{1}{2981.36 \times 0.02 \times 10^6} = \underline{\underline{0.01677 \times 10^6}}$$
$$= 0.01677 \times 10^6$$

$$V_0(t) = \frac{960 \times 10^3}{420 \times 0.001 \times 10^6} [e^{-\alpha t} - e^{-\beta t}]$$
$$= \frac{960 \times 10^3}{420 \times 0.001 \times 10^6} [2.38 \times 10^6 - 0.01677 \times 10^6]$$

$$t_1 = 1.2 \mu\text{s}$$

$$V_0(t) = \frac{960 \times 2.38 \times 10^6}{(2.38 - 0.01677) \times 10^6} [e^{-\alpha t_1} - e^{-\beta t_1}]$$
$$= 966 [0.057 - 0.979] = \underline{\underline{890.65 \text{ kV}}}$$

------(6 Marks)

6(b) **Trigatron Gap**

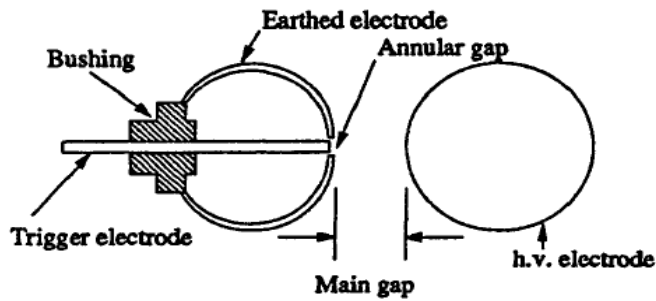
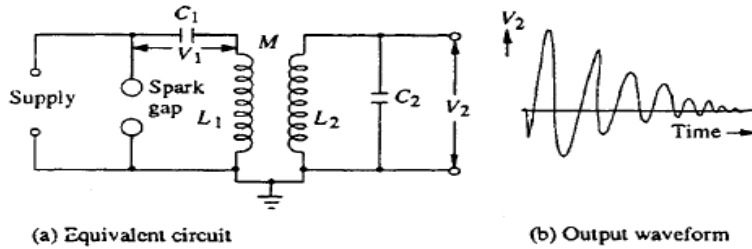

Fig. 6.24 (a) Trigatron gap

- Now-a-days a trigatron gap is used, and this requires much smaller voltage for operation compared to the three electrode gap.
- A trigatron gap consists of a high voltage spherical electrode of suitable size, an earthed main electrode of spherical shape, and a trigger electrode through the main electrode.
- The trigger electrode is a metal rod with an annular clearance of about 1 mm fitted into the main electrode through a bushing.
- The trigatron is connected to a pulse circuit as shown in Fig. 6.24b.
- Tripping of the impulse generator is affected by a trip pulse which produces a spark between the trigger electrode and the earthed sphere.
- Due to space charge effects and distortion of the field in the main gap, sparkover of the main gap occurs.
- The trigatron gap is polarity sensitive and a proper polarity pulse should be applied for correct operation

------(4 Marks)

7(a) **Construction & Working principle of Tesla coil**



- A spark gap G connected across the primary is triggered at the desired voltage V_1 which induces a high self-excitation in the secondary.
- The primary and the secondary windings (L_1) and (L_2) are wound on an insulated former with no core (air-cored) and are immersed in oil.
- The windings are tuned to a frequency of 10 to 100 kHz by means of the condensers C_1 and C_2
- Output voltage V_2 is a function of L_1 , L_2 , C_1 , C_2 , M .
- Winding resistances will be small, contribute only for damping of the oscillations.
- Neglecting the winding resistances.
- Let the condenser C_1 be charged to a voltage V_1 when the spark gap is triggered.
- Let a current i_1 flow through the primary winding L_1 and produce a current i_2 through L_2 and C_2

$$V_1 = \frac{1}{C_1} \int_0^t i_1 dt + L_1 \frac{di_1}{dt} + M \frac{di_2}{dt}$$

$$0 = \frac{1}{C_2} \int_0^t i_2 dt + L_2 \frac{di_2}{dt} + M \frac{di_1}{dt}$$

© Laplace transformed equation :

$$\frac{V_1}{s} = \left[L_1 s + \frac{1}{C_1 s} \right] I_1 + M s I_2$$

$$0 = [M s] I_1 + \left[L_2 s + \frac{1}{C_2 s} \right] I_2$$

7(b) Voltage Doubler Circuits

Voltage Multiplier Circuits.

- Both full wave and half wave rectifier circuits produce a d.c. voltage less than the a.c. maximum voltage. When higher d.c. voltages are needed, a voltage multiplier or cascaded rectifier circuits are used.
- The most simplest of the multiplier circuits is a voltage doubler circuit.
- In this circuit, the condenser C_1 is charged through rectifier R_1 to a voltage of $+V_{max}$ with polarity as shown in the figure during the negative half cycle.

- As the voltage of the transformer rises to positive V_{max} during the next half cycle, the potential of the other terminal of C_1 rises to a voltage of $+2V_{max}$.
- Thus, the condenser C_2 in turn is charged through R_2 to $2V_{max}$.
- Normally the d.c. output voltage on load will be less than $2V_{max}$, depending on the time constant $C_2 R_L$, and the forward charging time constants.
- The ripple voltage of these circuits will be about 2%. The rectifiers are rated to a peak inverse voltage of $2V_{max}$, and the condensers C_1 and C_2 must also have the same rating. If the load current is large, the ripple also is more.

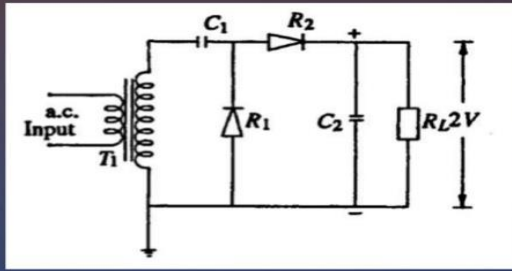

Simple Voltage Doubler Circuit

----- (5 Marks)

The dc charging voltage for 8 steps,

$$V = 8 \times \text{Charging voltage}$$

$$= 8 \times 120 \text{ kV} = \underline{\underline{960 \text{ kV}}}$$

The maximum output voltage is

$$V_0(t) = \frac{V}{R_1 C_2 (\alpha - \beta)} (e^{-\alpha t} - e^{-\beta t})$$

(For fig (b))

$$\therefore V_0(t) = \frac{960 \times 10^3}{420 \times 0.001 \mu\text{F} (\alpha - \beta)} [e^{-\alpha t} - e^{-\beta t}]$$

$$\text{Here } \alpha = \frac{1}{R_1 C_2} = \frac{1}{420 \times 0.001 \mu\text{F}} = \underline{\underline{2.38 \times 10^6}}$$

$$\beta = \frac{1}{R_2 C_1} = \frac{1}{2981.36 \times 0.02 \times 10^6} = \underline{\underline{0.01677 \times 10^6}}$$
$$= \underline{\underline{0.01677 \times 10^6}}$$

$$V_0(t) = \frac{960 \times 10^3}{420 \times 0.001 \times 10^6} [e^{-\alpha t} - e^{-\beta t}]$$
$$= \frac{960 \times 10^3}{420 \times 0.001 \times 10^6} [2.38 \times 10^6 - 0.01677 \times 10^6]$$

$$t_1 = 1.2 \mu\text{s}$$

$$V_0(t) = \frac{960 \times 2.38 \times 10^6}{(2.38 - 0.01677) \times 10^6} [e^{-\alpha t_1} - e^{-\beta t_1}]$$
$$= 966 [0.057 - 0.979] = \underline{\underline{890.65 \text{ kV}}}$$

