

Electric Vehicle-18EE752

Scheme and Evaluation

1.

CHOPPER CONTROL OF DC MOTORS

- Choppers are used for the control of DCM because of a number of advantages such as
 - High efficiency
 - Flexibility in control
 - Light weight
 - Small size
 - Quick response
 - Regeneration down to very low speeds.
- Presently the separately excited DC motors are usually used in traction, due to the control flexibility of armature voltage and field. But for applications where open-loop and closed-loop configurations of DC motor control is needed, chopper offers a number of advantages.
- High operation frequency results in high-frequency output voltage ripple and, therefore, less ripples in the motor armature current and a smaller region of discontinuous conduction in the speed–torque plane.
- A reduction in the armature current ripple reduces the armature losses. A reduction or elimination of the discontinuous conduction region improves speed regulation and the transient response of the drive.

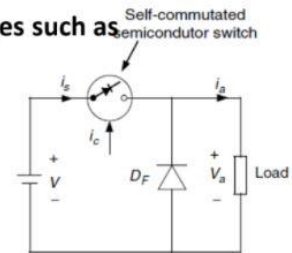

CHOPPER CONTROL OF DC MOTORS

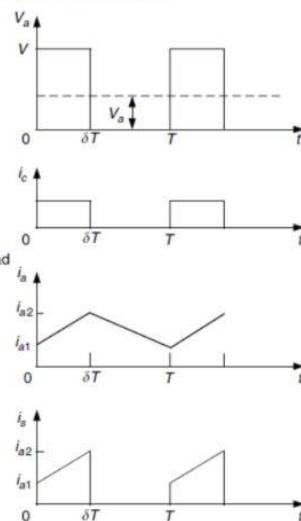
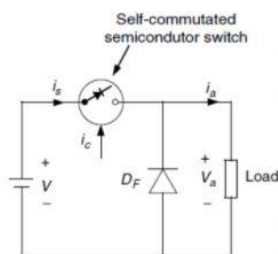

CONSTRUCTION

- The power electronic circuit and the steady-state waveform of a DC chopper drive are shown in Figure.
- A DC voltage source, V , supplies an inductive load through a self-commutated semiconductor switch S .
- The circuit can be built using any device among thyristors with an inbuilt forced commutation circuit: GTO, Power transistor, MOSFET, and IGBT.
- A diode D_F is connected in parallel with the to show the direction in which the device can carry current.
- The switch S is operated periodically over a period T and remains closed for a time.

$$t_{on} = \delta T \quad \text{with } 0 < \delta < 1$$

CHOPPER CONTROL OF DC MOTORS

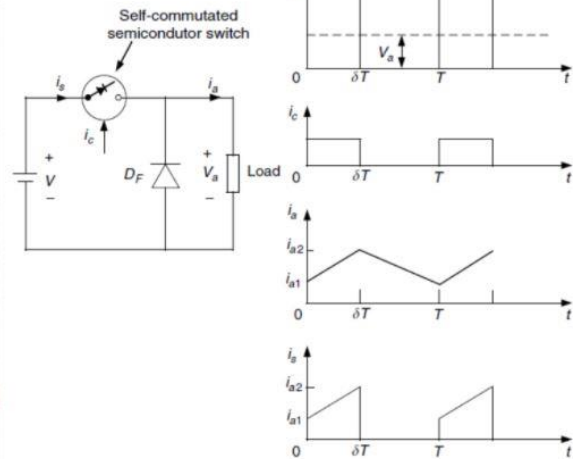

- The variable

$$\delta = t_{on} / T$$

is called the duty ratio or duty cycle of a chopper.

- Figure also shows the waveform of control signal i_c . Control signal i_c will be the base current for a transistor chopper, and a gate current for the GTO.
- If a power MOSFET is used, the control signal will be gate to the source voltage. When the control signal is present, the semiconductor switch S will conduct.
- The circuit operation is arranged in such a way that the removal of Control signal i_c will turn off the switch.

CHOPPER CONTROL OF DC MOTORS

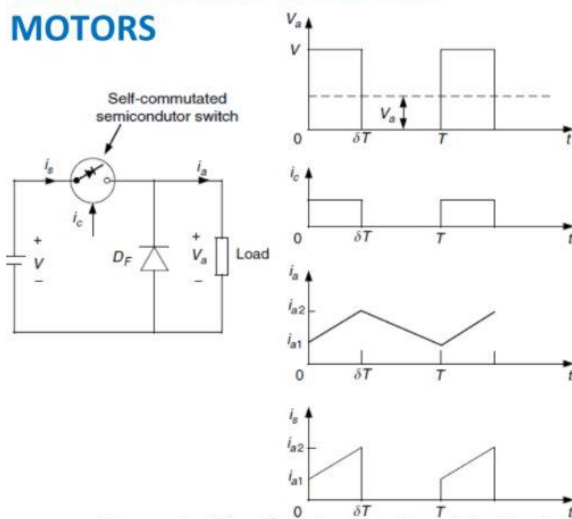

By controlling δ between 0 and 1, the load voltage can be varied from 0 to V; thus, a chopper allows a variable DC voltage to be obtained from a fixed voltage DC source.

WORKING

- During the on interval (Duty interval) of the switch $(0 \leq t \leq \delta T)$ the load is subjected to a voltage V and the load current increases from i_{a1} to i_{a2} .
- The switch is opened at $t = \delta T$.
- During the off period (Free wheeling interval) of the switch i.e. $(\delta T \leq t \leq T)$ Diode D_F provides a path for the load current to flow when switch S is off, and thus improves the load current waveform.

The source current flows only during the duty interval and is equal to the load current.

- The average value of the load voltage V_a is given by

$$V_a = \frac{1}{T} \int_0^{\delta T} V dt$$

2.

STEADY-STATE EQUIVALENT CIRCUIT OF THE ARMATURE OF A DC MOTOR

- The steady-state equivalent circuit of the armature of a DC motor is shown in figure.
- The resistor R_a is the resistance of the armature circuit.
 - For separately excited and shunt DC motors, it is equal to the resistance of the armature windings
 - For the series and compound motors, it is the sum of armature and series field winding resistances.

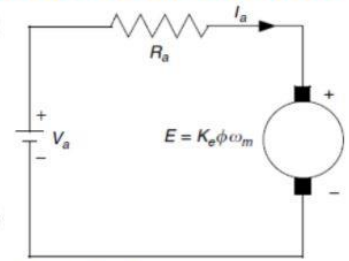

- Basic equations of a DC motor are where

$$V_a = E + R_a I_a$$

$$T = K_e \phi I_a$$

$$I_a = \frac{V_a - E}{R_a}$$

$$T = K_e \phi \left[\frac{V_a - E}{R_a} \right]$$

$$E = K_e \phi \omega_m$$

$$T = \frac{K_e \phi}{R_a} V - \frac{(K_e \phi)^2}{R_a} \omega_m$$

- I_a is the armature current in Amps
- V_a is the armature voltage in Volts
- ϕ is the flux per pole in Webers
- R_a is the resistance of the armature circuit in ohms
- ω_m is the speed of the armature in rad/sec
- T is the torque developed by the motor in Nm
- K_e is constant.

SPEED–TORQUE CHARACTERISTIC OF SEPARATELY EXCITED MOTORS

The steady state equations are applicable to all the DC motors.

SEPARATELY EXCITED MOTORS

- In the case of separately excited motors, The field voltage has to be maintained constant even if torque changes.
- In this case, the speed-torque characteristic of a separately excited motor is a straight line, as shown in the graph

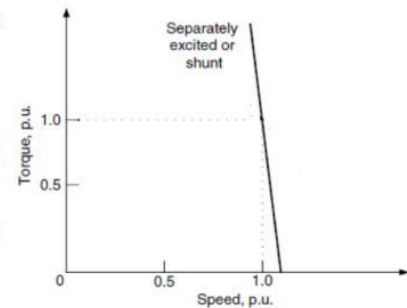

- The no-load speed ω_{m0} is determined by the values of the armature voltage and the field excitation.
- Speed decreases as torque increases, and speed regulation depends on the armature circuit resistance.
- Separately excited motors are used in applications requiring Good speed regulation and proper adjustable speed

3.

POWER ELECTRONIC CONTROL

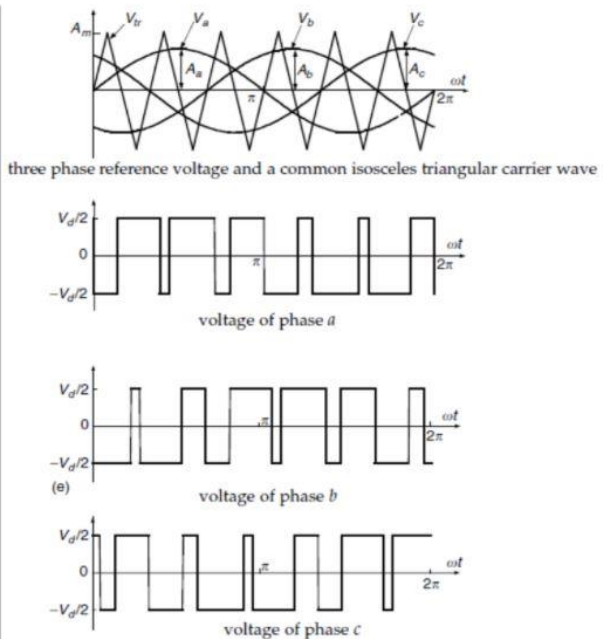
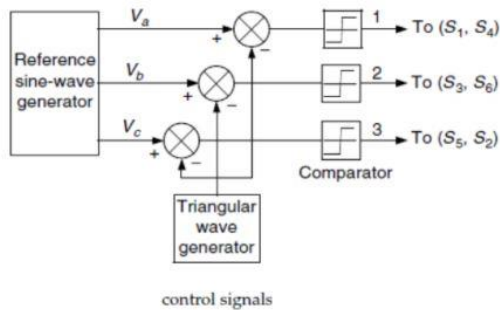
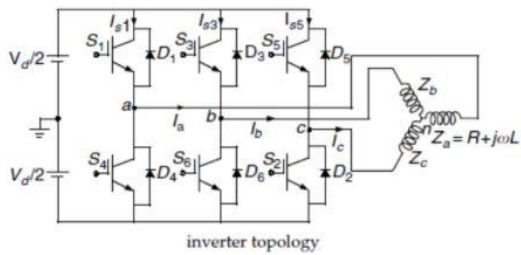

- As EV and HEV propulsion, an induction motor drive is usually fed with a DC source (battery, fuel cell, etc.), which has approximately constant terminal voltage. Thus, a variable frequency and variable voltage DC/AC inverter is needed to feed the induction motor. The general DC/AC inverter is constituted by power electronic switches and power diodes.
- The commonly used topology of a DC/AC inverter is shown in Inverter topology Figure which has three legs (S1 and S4, S3 and S6, and S5 and S2), feeding phase a, phase b, and phase c of the induction motor.
- When switches S1, S3, and S5 are closed, S4, S6, and S2 are opened, and phases a, b, and c are supplied with a positive voltage ($V_d/2$).
- Similarly, when S1, S3, and S5 are opened and S4, S6, and S2 are closed, phases a, b, and c are supplied with a negative voltage. All the diodes provide a path for the reverse current of each phase.
- Three-phase reference voltages V_a , V_b , and V_c of variable amplitudes A_a , A_b , and A_c are compared with a common isosceles triangular carrier wave V_{tr} of a fixed amplitude A_m as shown in three phase reference voltage and a common isosceles triangular carrier wave Figure.
- The outputs of comparators 1, 2, and 3 form the control signals for the three legs of the inverter. When the sinusoidal reference voltage V_a , V_b , and V_c at a time t is greater than the triangular waved voltage, turn-on signals are sent to the switches S1, S3, and S5 and turn-off signals are sent to S4, S6, and S2.
- Thus, the three phases of the induction motor have a positive voltage. On the other hand, when the reference sinusoidal voltage is smaller than the triangular wave voltage, turn-on signals are sent to the switches S1, S3, and S5 and turn-off signals are sent to S4, S6, and S2.
- The three phases of the induction motor then have a negative voltage. The voltages of the three phases are shown in voltage of phase a; voltage of phase b; and voltage of phase c Figure.

- The frequency of the fundamental component of the motor terminal voltage is the same as that of the reference sinusoidal voltage.
- Hence, the frequency of the motor voltage can be changed by the frequency of the reference voltage.
- The ratio of the amplitude of the reference wave to that of the triangular carrier wave, m , is called the modulation index; therefore

$$m = \frac{A}{A_m}, \quad (6.39)$$

where A is the multitude of the reference sinusoidal voltage, V_{ar} , V_{br} or V_{cr} and A_m is the multitude of angular carrier voltage. The fundamental (rms) component in the phase waveform, V_{ar} , V_{br} or V_{cr} is given by

$$V_f = \frac{mV_d}{2\sqrt{2}}. \quad (6.40)$$

Thus, the fundamental voltage increases linearly with m until $m = 1$ (that is, when the amplitude of the reference wave becomes equal to that of the carrier wave). For $m > 1$, the number of pulses in V_{ar} , V_{br} or V_{cr} becomes less and the modulation ceases to be sinusoidal.²

4.

Control of BLDC Motor Drives

- In vehicle traction application, the torque produced is required to follow the torque desired by the driver and commanded through the accelerator and brake pedals. Thus, torque control is the basic requirement.
- The desired current I^* is derived from the commanded torque T^* through a torque controller. The current controller and commutation sequencer receive the desired current I^* position information from the position sensors, and perhaps the current feedback through current transducers, and then produces gating signals.
- These gating signals are sent to the three-phase inverter (power converter) to produce the phase current desired by the BLDC machine.

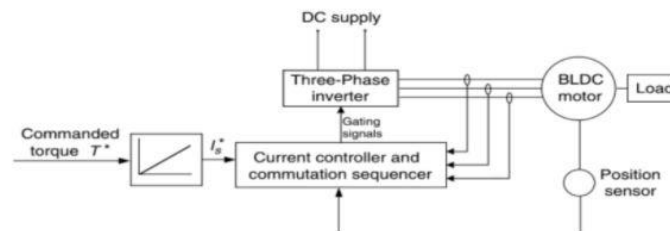

FIGURE 6.51
Block diagram of the torque control of the BLDC motor

- In traction application, speed control may be required, Many high-performance applications include current feedback for torque control. At the minimum, a DC bus current feedback is required to protect the drive and machine from over currents.
- The controller blocks, “speed controller” may be any type of classical controller such as a PI controller, or a more advanced controller such as an artificial intelligence control. The “current controller and commutation sequencer” provides the properly sequenced gating signals to the “three-phase inverter” while comparing sensed currents to a reference to maintain a constant peak current control by hysteresis (current chopping) or with a voltage source (PWM)-type current control.
- Using position information, the commutation sequencer causes the inverter to “electronically commute,” acting as the mechanical commutator of a conventional DC machine.

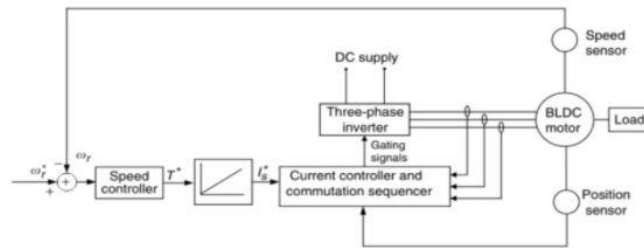

FIGURE 6.52
Block diagram of the speed control of the BLDC motor

5.

OPERATING PATTERNS

The engine should be controlled in such a way that it always operates in its optimal operation region, where fuel consumption and emissions of the engine are minimized

The drive train has several operating modes, which can be used selectively according to the driving condition and desire of the driver the following operating modes are available

- **Hybrid traction mode**
- **Peak Power Source-Alone Traction Mode**
- **Engine/Generator-Alone Traction Mode**
- **PPS Charging from the Engine/Generator**
- **Regenerative Braking Mode**

OPERATING PATTERNS

The vehicle controller commands the operation of each component according to the traction power (torque) command from the driver, the feedback from each of the components, and also the drive train and the preset control strategy. The control objectives are to

- **Meet the power demand of the driver**
- **Operate each component with optimal efficiency**
- **Recapture braking energy as much as possible**
- **Maintain the state-of-charge (SOC) of the PPS in a preset window.**

OPERATING PATTERNS

HYBRID TRACTION MODE

When a large amount of power is demanded, that is, the driver depresses the accelerator pedal deeply, both engine/generator and peaking power source (PPS) supply their powers to the electric motor drive. In this case, the engine should be controlled to operate in its optimal region for efficiency and emission reasons. The PPS supplies the additional power to meet the traction power demand. This operation mode can be expressed as

$$P_{demand} = P_{e/g} + P_{pps}$$

PEAK POWER SOURCE-ALONE TRACTION MODE

In this operating mode, the peak power source alone supplies its power to meet the power demand, that is,

$$P_{demand} = P_{pps}$$

ENGINE/GENERATOR-ALONE TRACTION MODE

In this operating mode, the engine/generator alone supplies its power to meet the power demand, that is,

$$P_{demand} = P_{e/g}$$

OPERATING PATTERNS

PPS CHARGING FROM THE ENGINE/GENERATOR

When the energy in the PPS decreases to a bottom line, the PPS must be charged. This can be done by regenerative braking or by the engine/generator. Usually, engine/generator charging is needed, since regenerative braking charging is insufficient. In this case, the engine power is divided into two parts one which is used to propel the vehicle and the other is used to charge the PPS. That is,

$$P_{demand} = P_{e/g} - P_{pps}$$

REGENERATIVE BRAKING MODE

When the vehicle is braking, the traction motor can be used as a generator, converting part of the kinetic energy of the vehicle mass into electric energy to charge the PPS.

6.

Maximum State-of-Charge of Peaking Power Source (Max. SOC-of-PPS) Control Strategy

- When a vehicle is operating in a stop-and-go driving pattern, the PPS must deliver its power to the drive train frequently.
- Consequently, the PPS tends to be discharged quickly. In this case, maintaining a high SOC in the PPS is necessary to ensure vehicle performance.
- Thus, the maximum SOC of the PPS control strategy may be the proper option.

- The maximum power curves for hybrid traction (engine plus electric motor), engine-alone traction, electric motor-alone traction, and regenerative braking are plotted against vehicle speed. Power demands in different conditions are also plotted, represented by points A, B, C, and D.
- The operation modes of the drive train are explained below:
 - Motor-alone propelling mode
 - Hybrid propelling mode
 - PPS charge mode
 - Engine-alone propelling mode
 - Regenerative-alone brake mode
 - Hybrid braking mode

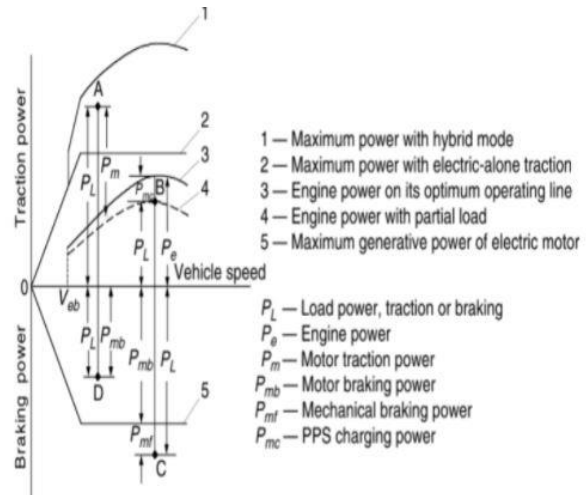

1. Motor-alone propelling mode:

The vehicle speed is less than a preset value V_{eb} , which is considered to be the bottom line of the vehicle speed below which the engine cannot operate steadily. In this case, the electric motor alone delivers its power to the driven wheels, while the engine is shut down or idling. The engine power, electric traction power, and the PPS discharge power can be written as

$$P_e = 0,$$

$$P_m = \frac{P_L}{\eta_{t,m}},$$

$$P_{pps-d} = \frac{P_m}{\eta_m},$$

where
 P_e is the engine power output,
 P_L is the load power demand on the drive wheels,
 $\eta_{t,m}$ is the transmission efficiency from the motor to the driven wheels,
 P_m is the power output of the electric motor,
 P_{pps-d} is the PPS discharge power, and
 η_m is the motor efficiency.

2. Hybrid propelling mode:

- The load power demand, represented by point A, is greater than what the engine can produce, both the engine and electric motor must deliver their power to the driven wheels at the same time.
- This is called hybrid propelling mode.
- In this case, the engine operation is set on its optimum operation line by controlling the engine throttle to produce power P_e .
- The remaining power demand is supplied by the electric motor. The motor power output and PPS discharge power are

$$P_m = \frac{P_L - P_e \eta_{t,e}}{\eta_{t,m}},$$

$$P_{pps-d} = \frac{P_m}{\eta_m},$$

- where $\eta_{t,e}$ is the transmission efficiency from the engine to the drive wheels.

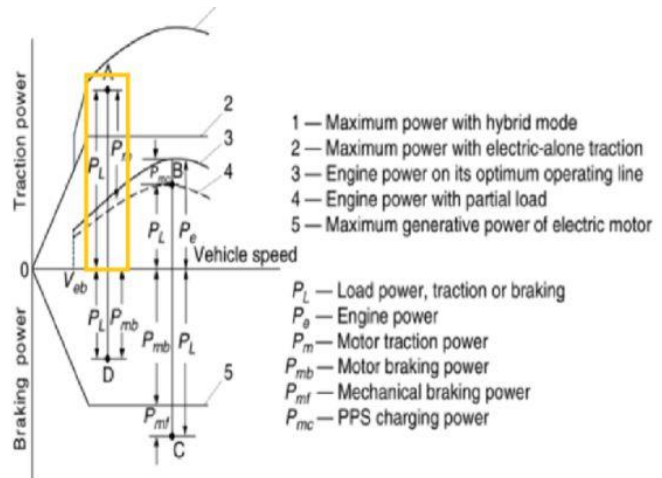

3. PPS charge mode:

- When the load power demand, represented by point B is less than the power that the engine can produce while operating on its optimum operation line, and the PPS SOC is below its top line, the engine is operated on its optimum operating line, producing its power P_e .
- In this case, the electric motor is controlled by its controller to function as a generator, powered by the remaining power of the engine.
- The output power of the electric motor and PPS charge power are

$$P_m = \left(P_e - \frac{P_L}{\eta_{t,e}} \right) \eta_{t,e,m} \eta_{m} \\ P_{pps-c} = P_{mf}$$

- where $\eta_{t,e,m}$ is the transmission efficiency from the engine to the electric motor.

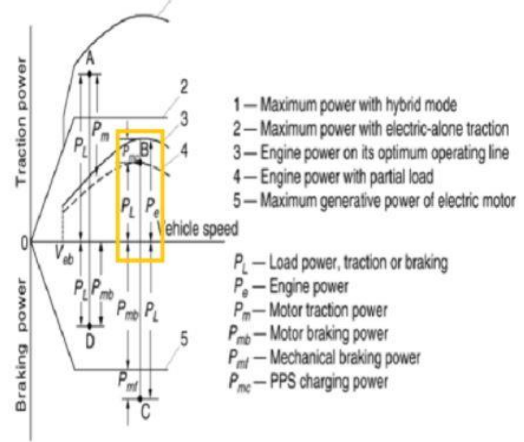

4. Engine-alone propelling mode:

- When the load power demand is less than the power that the engine can produce while operating on its optimum operation line, and the PPS SOC has reached its top line, the engine-alone propelling mode is used. In this case, the electric system is shut down, and the engine is operated to supply the power that meets the load power demand.
- The power output curve of the engine with a partial load is represented by the dashed line.
- The engine power, electric power, and battery power can be expressed by

$$P_e = \frac{P_L}{\eta_{t,e}}, \\ P_m = 0, \\ P_{pps} = 0.$$

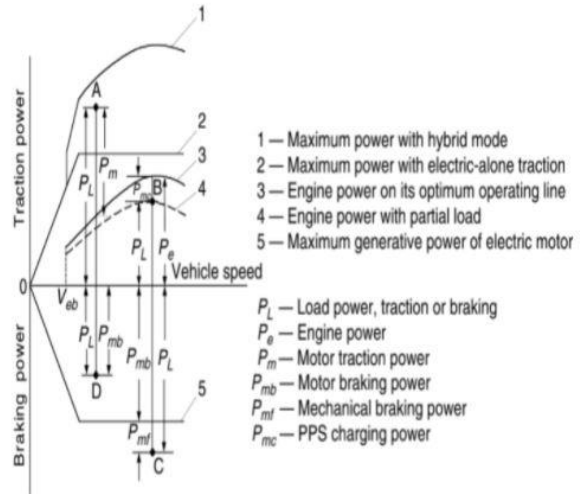

5. Regenerative-alone brake mode:

- When the vehicle experiences braking and the demanded braking power is less than the maximum regenerative braking power that the electric system can supply (as shown by point D), the electric motor is controlled to function as a generator to produce a braking power that equals the commanded braking power.
- In this case, the engine is shut down or set idling. The motor power output and PPS charge power are

$$P_{mb} = P_L \eta_{t,m} \eta_{m} \\ P_{pps-c} = P_{mb}$$

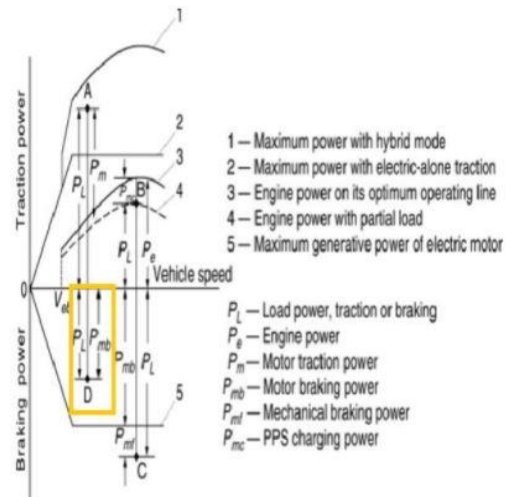

6. Hybrid braking mode:

- When the demanded braking power is greater than the maximum regenerative braking power that the electric system can supply (as shown by point C), the mechanical brake must be applied.
- In this case, the electric motor should be controlled to produce its maximum regenerative braking power, and the mechanical brake system should handle the remaining portion.
- The motor output power, battery charging power, and mechanical braking power are

$$P_{mb} = P_{mb,max} \eta_m'$$

$$P_{pps-c} = P_{mb}$$

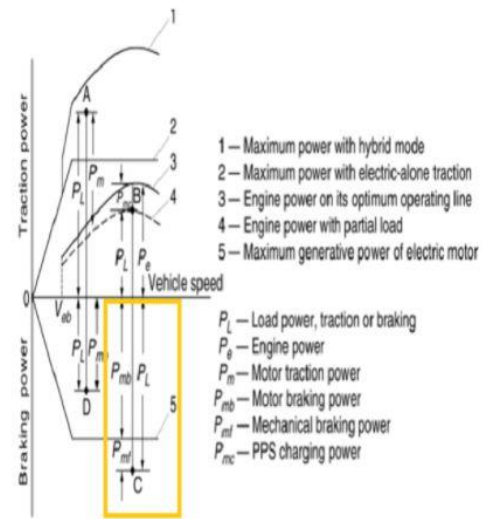

7.

Design of Engine Power Capacity

- The engine should be able to supply sufficient power to support the vehicle operation at normal constant speeds both on a flat and a mild grade road without the help of the PPS.
- At the same time, the engine should be able to produce an average power that is larger than the average load power when the vehicle operates with a stop-and-go operating pattern.
- As a requirement of normal highway driving at constant speed on a flat or a mild grade road, the power needed is expressed as

$$P_e = \frac{V}{1000 \eta_{t,e}} \left(M_v g f_r + \frac{1}{2} \rho_a C_D A_f V^2 + M_v g i \right) (\text{kW}).$$

- The average load power of a vehicle can be calculated by

$$P_{ave} = \frac{1}{T} \int_0^T \left(M_v \delta f_r V + \frac{1}{2} \rho_a C_D A_f V^3 + \delta M_v V \frac{dV}{dt} \right) dt.$$

- The average power varies with the degree of regenerative braking. The two extreme cases are the full and zero regenerative braking cases. Full regenerative braking recovers all the energy consumed in braking.
- However, when the vehicle has no regenerative braking, the average power is larger than that with full regenerative braking.
- The average power that the engine can produce with full throttle can be calculated as

$$P_{max-ave} = \frac{1}{T} \int_0^T P_e(v) dt,$$

Design of Electric Motor Drive Power Capacity

- In HEV, the major function of the electric motor is to supply peak power to the drive train. In the motor power design, acceleration performance and peak load power in typical drive cycles are the major concerns.
- It is difficult to directly design the motor power from the acceleration performance specified. It is necessary to make a good estimate based on specified acceleration requirements, and then make a final design through accurate simulation.
- As an initial estimate, one can make the assumption that the steady-state load (rolling resistance and aerodynamic drag) is handled by the engine and the dynamic load (inertial load in acceleration) is handled by the motor.
- With this assumption, acceleration is directly related to the torque output of an electric motor by

$$\frac{T_m i_{t,m} \eta_{t,m}}{r} = \delta_m M_v \frac{dV}{dt},$$

- where T_m is the motor torque and δ_m is the mass factor associated with the electric motor.

- the motor power rating is expressed as

$$P_m = \frac{\delta_m M_v}{2\eta_{t,m} t_a} (V_f^2 + V_b^2).$$

- The average power of the engine, used to accelerate the vehicle, can be expressed as

$$P_{e,a} = \frac{1}{t_a - t_i} \int_{t_i}^{t_a} (P_e - P_r) dt,$$

- where P_e and P_r are the engine power and resistance power, respectively.
- It should be noted that the engine power transmitted to the driven wheels is associated with the transmission, that is, the gear number and gear ratios.

Energy Storage Design

- The energy storage design mainly includes the design for the power and energy capacity. The power capacity design is somewhat straightforward.
- The terminal power of the energy storage must be greater than the input electric power of the electric motor, that is,

$$P_s \geq \frac{P_m}{\eta_m},$$

- where P_m and η_m are the motor power rating and efficiency.
- During the acceleration period, the energies drawn from energy storage and the engine can be calculated along with the calculation of the acceleration time and distance by

$$E_s = \int_0^{t_a} \frac{P_m}{\eta_m} dt$$

$$E_{eng} = \int_0^{t_a} P_e dt,$$

- where E_s and E_{eng} are the energy drawn from the energy storage and the engine, respectively, and P_m and P_e are the powers drawn from the motor and engine, respectively.

- The energy capacity of the energy storage must also meet the requirement while driving in a stop-and-go pattern in typical drive cycles. The energy changes of the energy storage can be obtained by

$$E_c = \int_0^t (P_{sc} - P_{sd}) dt,$$

- where Psc and Psd are the charging and discharging power of the energy storage.
- The energy capacity of the energy storage can be obtained as

$$E_{cs} = \frac{E_D}{SOC_t - SOC_b},$$

- where Ed is the energy discharged from the energy storage, and SOct and SOCb are the top line and bottom line of the SOC of the energy storage.