

**Scheme Of Evaluation**  
**Internal Assessment Test 4**



<b>Sub:</b>	Testing and Commissioning of Power System Apparatus					<b>Code:</b>	17EE752		
<b>Date:</b>	2/1/2021	<b>Duration:</b>	90mins	<b>Max Marks:</b>	50	<b>Sem:</b>	VII	<b>Branch:</b>	EEE

**Note:** Answer Any Five Questions

Question #	Description	Marks Distribution		Max Marks	
1	<p>a) <b>Enumerate the protective devices and accessories fitted on the power transformer.</b></p> <ul style="list-style-type: none"> <li>• List of all the devices and accessories</li> <li>Flow /Oil Level Indicator</li> <li>Pressure Relief Valve</li> <li>Buchholz Relay</li> <li>Sudden Pressure Relay</li> <li>Conservator</li> <li>Breather</li> <li>Oil Temperature Indicator</li> <li>Winding Temperature Indicator</li> <li>Marshalling Kiosk/Control Cabinet</li> <li>Surge Arrestor</li> <li>• Elaborate any 4 devices and accessories (each 2 marks)</li> </ul>	2 M	8M	10 M	
2	<p>a) <b>State the important steps in maintenance of power transformer.</b></p> <div style="border: 1px solid black; padding: 5px;"> <p style="text-align: center; background-color: #008080; color: white; margin: 0;"><b>Maintenance Of Transformer</b></p> <div style="display: flex; justify-content: space-between;"> <div style="width: 45%; border: 1px solid black; padding: 2px;"> <p><b>Regular/routine inspection and minor work</b></p> <ul style="list-style-type: none"> <li>- No dismantling</li> <li>- Visual inspection,</li> <li>- Sample gas from Buchholz relay,</li> <li>- check oil level, cooling system ,</li> <li>check fitments</li> </ul> </div> <div style="width: 45%; border: 1px solid black; padding: 2px;"> <p><b>Medium Repair(Tests and Reconditioning)</b></p> <ul style="list-style-type: none"> <li>- Minor dismantling associated</li> <li>- Minor repair and inspection</li> <li>- Defects that couldn't be corrected in routine inspection is rectified.</li> <li>- Repair of conservator tank, tap changer, cooling system</li> </ul> </div> </div> <div style="border: 1px solid black; padding: 2px; margin-top: 5px;"> <p><b>Major Repair Work</b></p> <ul style="list-style-type: none"> <li>- 8-10 yrs/ major failure</li> <li>- windings, insulation material, tightening of core laminations</li> </ul> </div> </div>	4 M	1 M	5 M	10 M

a)

**What is the? Explain the principle of off-circuit tap changer and on-load tap changer?**

- Function of tap changer

The change of voltage is affected by changing the numbers of turns of the transformer provided with taps. For sufficiently close control of voltage, taps are usually provided on the high voltage windings of the transformer. There are two types of tap-changing transformers

- Principle of off-circuit tap changer with neat diagram

In this method, the transformer is disconnected from the main supply when the tap setting is to be changed. The tap setting is usually done manually. The off load tap changing transformer is shown in the figure below

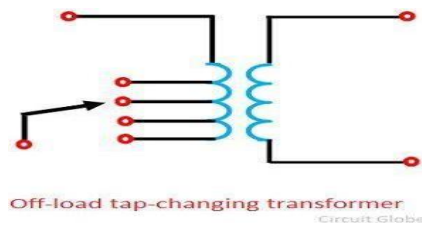

- Principle of on- load tap changer with neat diagram

In order that the supply may not be interrupted, on-load tap changing transformer are used. Such a transformer is known as a tap-changing under load transformer. While tapping, two essential conditions are to be fulfilled.

The load circuit should not be broken to avoid arcing and prevent the damage of contacts.

No parts of the windings should be short-circuited while adjusting the tap.

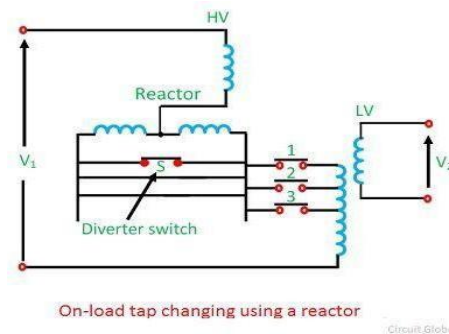

The tap changing employing a center tapped reactor R show in the figure above. Here S is the diverter switch, and 1, 2, 3 are selector switch. The transformer is in operation with switches 1 and S closed. To change to tap 2, switch S is opened, and 2 is closed. Switch 1 is then opened, and S closed to complete the tap change. It is to be noted that the diverter switch operates on load, and no current flows in the selector switches during tap changing. It is to be noted that the diverter switch operates on load, and no current flows in the selector switches during tap changing. During the tap change, only half of the reactance which limits the current is connected in the circuit.

3

2 M

2+2  
M

2+2  
M

10  
M

10 M

Explain phasor diagram and phasor groups adopted for standard connection of a transformer.

a)

- Mention all the phasor groups

Table 1.1: Standard Phasor Groups

Group	Phase displacement	Connections
I	$0^\circ$	Yy0, Dd0, Dz0
II	$180^\circ$	Yy6, Dd6, Dz6
III	$30^\circ$ lag	Dy1, Yd1, Yz1
IV	$30^\circ$ lead	Dy11, Yd11, Yz11

- Explain any 3 phasor groups with phasor diagram ( each 3 marks)

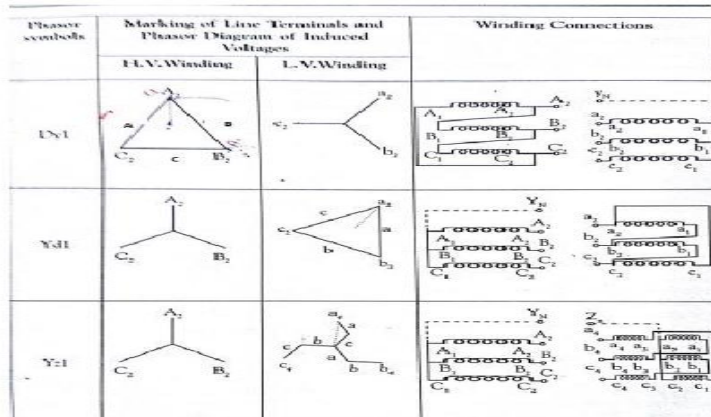
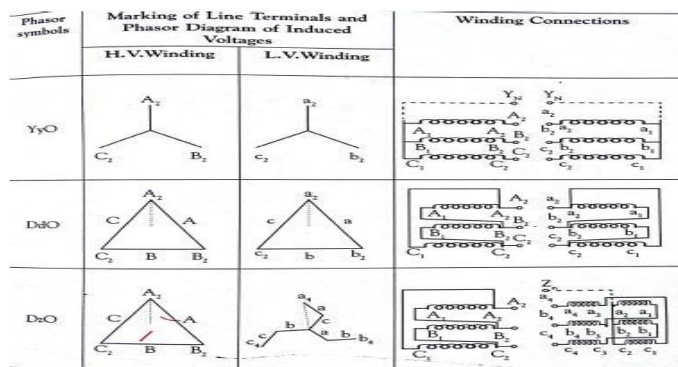
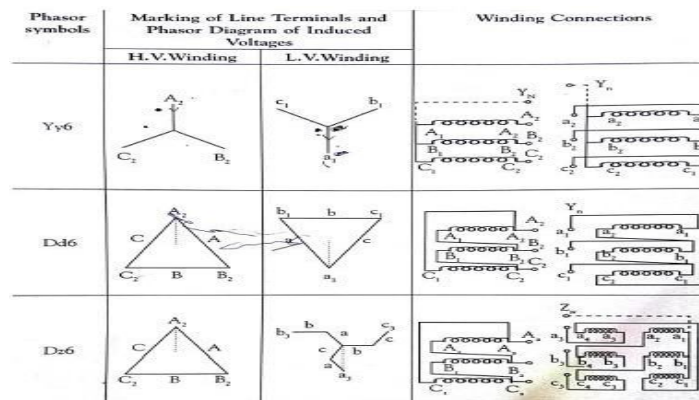

4

1 M

9 M

10 M

10 M

5	<p>a) <b>Explain the different drying techniques used in transformers / power transformers.</b></p> <ul style="list-style-type: none"> <li>• Name the techniques</li> </ul> <p>Different methods of drying out:</p> <ol style="list-style-type: none"> <li>i) Drying of core and coils with oil by oven</li> <li>ii) Drying of core and coils with oil by short circuit method</li> <li>iii) Drying with oil removed by using external heat</li> <li>iv) Drying with oil removed by using both external and internal heat.</li> </ol> <ul style="list-style-type: none"> <li>• Explain any 3 techniques ( each 3 marks)</li> </ul> <p><b>Drying with oil:</b></p> <p>i) <b>Drying of core and coils with oil by using oven.</b> The core and coils can be effectively dried in a suitable oven, by raising the temperature to a value not exceeding 80°e. A large volume of air should pass through -the oven to remove moisture and vapors. Insulation resistance check will indicate when the coils are dry.</p> <p>ii) <b>Drying by short circuit method:</b> The transformer can also be dried by heating the coils by short circuiting the low voltage winding and supplying a reduced voltage at the terminals. Current should not exceed 70% of the rated current and oil temperature should not exceed 75°e. The winding temperature under no condition should exceed 90°e. This method is more effective in drying the insulation at site.</p> <p><b>Drying without oil:</b></p> <p><b>By external heat:</b> The transformer may be placed in its own tank without oil. Externally heated air is blown into the tank at the bottom through the main oil valve. A small blower or fan should be used to get the proper circulation. It is desired to-force as much of the heated air as possible through the ducts in the transformer windings. To accomplish this, baffles should be placed between the core and the case, closing off as much of the space as possible. The convenient way to get the heated air is by passing air through grid resistors. The resistors are in fire proof box. The temperature of the air should not exceed 115°C. The heat may also be obtained by direct combustion but care is to be taken to avoid the products of combustion entering into the transformer tank.</p> <p><b>By both external and internal heat:</b> This is a combination of the hot air circulation and short circuit method. The current circulated in the windings should, of course, be less than that when drying out is done by the method of short circuit alone.</p>	1 M	9 M	10 M
---	---	-----	-----	------

6	a)	<p><b>Explain installation, inspection upon arrival at site and storage facility at site.</b></p> <ul style="list-style-type: none"> <li>● Installation procedure</li> </ul> <p><b>Installation:</b>  <b>Location, site preparation and foundation details:</b>  The location may be indoor or outdoor.  For indoor installation, the following aspects should be considered.</p> <ul style="list-style-type: none"> <li>✓ Ventilation</li> <li>✓ Noise level</li> <li>✓ Space required for movement, maintenance etc</li> <li>✓ Trenches for cables</li> </ul> <p>Minimum clearances between the transformer and the walls should be as follows.</p> <ul style="list-style-type: none"> <li>✓ Clearance on all four sides of wall: 1.25 m</li> <li>✓ Clearance on all three sides of wall: 1 m</li> <li>✓ Clearance on a wall on backside only: 0.5 m</li> <li>✓ The clearance of 0.5 m (minimum) should be provided between the top most point of the conservator and the roof.</li> </ul> <p>Ventilation area: The ventilation area required is as follows.</p> <ul style="list-style-type: none"> <li>✓ Outlet: 2m<sup>2</sup> per 1000 KVA</li> <li>✓ Inlet : 1m<sup>2</sup> per 1000 KVA minimum</li> </ul> <ul style="list-style-type: none"> <li>● Inspection procedure</li> </ul> <p><b>Inspection upon arrival at site:</b>  Immediately after arrival at site, it should be inspected for possible damages during transit. The nitrogen gas pressure should be checked. Positive pressure if not found, indicates that there is leakage, and there is a possibility of the moisture entering the tank during transit. This can be ascertained by dew point measurement which indicates the amount of surface moisture content in transformer insulation. Internal inspection should be carried out to the extent possible through inspection covers. Particular attention should be paid to the connections, bolt links, coil clamping bolts, tap changers. Current transformers and the general insulation. Break down strength of oil of transformer tank and drums containing transformer oil should be examined carefully. An inspection of the transformer on arrival at site is to be carried out preferably in the presence of the representative of the manufacturer.</p> <ul style="list-style-type: none"> <li>● Storage conditions and procedure</li> </ul> <p><b>Storage:</b>  The transformers arrived at site and likely to be installed immediately do not need elaborate storage. In case of delayed installation, it requires proper storage to avoid influx of moisture, effect of rain / dust etc. It is preferable to store the transformers indoor on proper flooring with protective covering. The oil should not be drained unless there is a provision of filling inert gas.</p>	2 M	5 M	10 M
			2 M		
			1 M		

b)

Explain the various type tests carried out on transformer before commissioning.

### b) Type Test-

1. Temperature Rise Test
2. Lightning Impulse Test
3. Air Pressure Test.
4. Noise Level Test.
5. Permissible flux density & over fluxing

#### TYPE TEST.

##### a) Temperature Rise Test.

- The test checks if the temperature of windings and the transformer tank/oil is increasing beyond the prescribed limit or not.
- The rise limit in temperature of the transformer tank can be obtained by placing thermometers at different points in the tank.
- Thermometers can be placed near the ~~cable tank inlet~~ and entry point outlet point of the cooling radiators and also in a pocket in the transformer top cover.

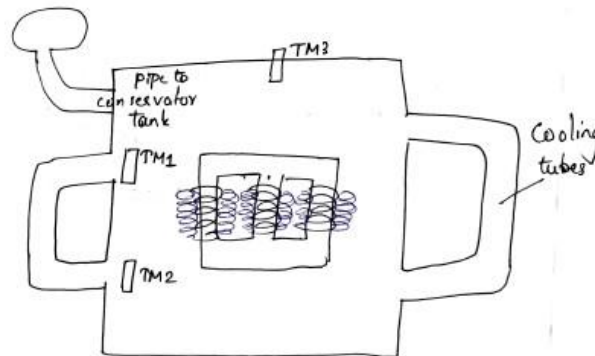

- TM3, TM1 and TM2 represents the thermometers.

1 M  
2 M  
2 M

5  
M





## Impulse Testing

- This test is to analyse the performance of transformer during lightning strokes/lightning impulses and switching impulses.
- Lightning is a very common phenomenon in transmission line.

The lightning strokes in transmission lines causes impulse voltage on the line which gets extended to the transformer also.

Thus, the terminal equipment (transformer) should withstand the lightning strokes.

- Also, switching impulses occur when every switching operation takes place. The magnitude of switching impulses can be 3.5 times the system voltage.
- So, to check if the transformer can withstand the switching impulses and lightning strokes, the impulse test is conducted.

The standard impulse waves are of three types

- Lightning Impulse =  $1.2/50\mu s$  with  $1.2\mu s$  as <sup>wave</sup> front and  $50\mu s$  as wave tail
- Switching Impulse =  $12/50\mu s$  250/2500  $\mu s$
- Chopped impulse wave =  $12/50\mu s$ .

## Partial Discharge Test. (P-D Test)

- Partial discharges are small electrical sparks that occur within the insulation of high voltage transformers due to air pockets within the insulation.
- It leads to small dielectric discharges in the air pockets (under high voltage stress) leading to dielectric failures.
- Partial discharges in the insulation deteriorates the insulation and cause failure in transformer.
- PD is observed in insulation bushings and windings.
- PD test is done to detect, assess and localize the PD source/air pocket. Necessary repairs can be adopted in the early stages to prevent failures of transformer.
- The main reasons of partial discharges are due to
  - Improper processing/drying of transformer insulation
  - Over stressing of insulation
  - High stress areas in the conductors
- It leads to
  - Ionization in cavities within solid insulation
  - Gas bubbles/voids in the insulation
  - Progressive deterioration of insulating material.



a)

Enumerate the various routine tests carried out on transformer before commissioning.

a) Routine Test.

1. Voltage Ratio Test
2. Polarity Test.
3. Winding Resistance Test.
4. Insulation Resistance Test.
5. Dielectric Test.
6. No load Test.

7

① ROUTINE TEST.

Polarity Test.

- This test shows the relative polarity between the primary and secondary of the transformer.
- Polarity can be of 2 types
  - Additive Polarity : Same terminals of 1° and 2° are being connected.
  - Subtractive Polarity : Here, ~~same~~ opposite terminals of 1° and 2° are connected.
- In subtractive polarity, the voltmeter connected across the 1° and 2° reads the ~~difference~~ <sup>difference</sup> btw two winding voltages.
- In additive polarity, the voltmeter reads the sum of the two winding voltages.

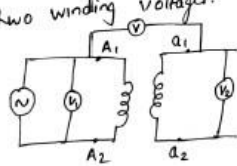

A<sub>1</sub>-A<sub>2</sub> = HV Winding  
a<sub>1</sub>-a<sub>2</sub> = LV Winding

The additive polarity shows the voltmeter, V with reading V<sub>1</sub>+V<sub>2</sub>

- In transformer, we assume generally that 1° and 2° are in phase. But that is not the case.
- The phase relationship between 1° and 2° currents and voltages depends on how each winding is wrapped around the core.
- In figure 1 below, the 1° and 2° are in phase as the direction of winding are in phase thus showing additive polarity.

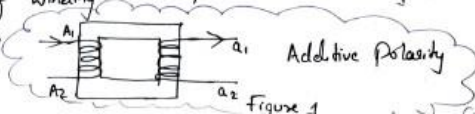

Figure 1

2 M

10 M

10 M

8 M

- Figure 2 shows subtractive polarity as  $1^\circ$  and  $2^\circ$  are wound in opposite direction. Here,  $1^\circ$  and  $2^\circ$  are  $180^\circ$  out of phase meaning it is subtractive polarity.

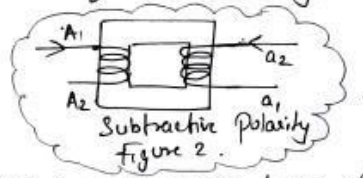

### b) Winding Resistance Test

- It helps to find the  $I^2R$  losses or copper losses of a transformer.
- The windings in the transformer has equal resistance along the length. It means the winding resistance per unit length is a constant along the windings of a transformer.
- To find the winding resistance, a steady dc current is applied at a stable temperature to the windings.
- The test can be done in 3 ways:

#### i) Bridge Method

eg: kelvins double bridge / Wheatstone's Bridge method.

#### ii) Volt-ampere Method

#### iii) Winding resistance measurement kit.

#### Bridge Method

- The main principle is based on comparison of unknown resistances with the known resistance.
- A bridge circuit has 4 resistance arms. Out of these

- The dc current  $\leq 15\%$  of rated current of the winding is given.
- Readings of  $V$  and  $I$  shall be taken after it has reached a steady value.

$$\text{Winding resistance/phase} = \frac{\text{Voltage/phase}}{\text{Current}}$$

- For star connection, the measurement is done across phase and neutral.
- For delta connection, the measurement is done across 2 phases.

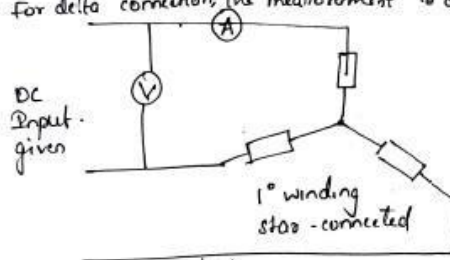

In the above circuit,

$$\text{the winding resistance/phase} = \frac{V}{2 \times I}$$

- The figure below shows a delta connection,

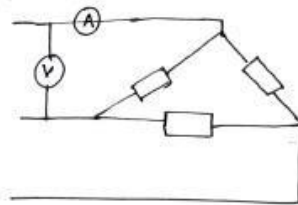

The winding resistance of the delta connection is

$$\text{Winding Resistance} = \frac{V}{I}$$

### Winding Resistance Measurement Kit

It helps us to accurately obtain the resistance in the digital meter with almost accuracy in ohms.

### c) Voltage Ratio Test.

- It is to ensure the correctness of voltage ratio between different tapings of the 1<sup>o</sup> and 2<sup>o</sup> windings.
- The tolerance allowed is  $\pm 0.5\%$  of the declared ratio or  $\pm 10\%$  of percentage impedance voltage which ever is lesser.
- Test can be done using calibrated voltmeter or by using special ratio testing apparatus called ratio meter.
- Ratio testing meter gives an accuracy of 0.1%.
- It uses a bridge circuit in which the voltages of the windings of the transformer under test are balanced against the voltages developed across the fixed and variable resistors of a bridge.
- The test is conducted on every transformer for position of every tap.

### d) Insulation Resistance Test.

- The test is to find the resistance between two conducting parts or between a conductor and earth.
- Insulation resistance is measured using MEGGAR. It consist of 3 terminals Earth, Line and Ground.
- Line terminal is connected to the conducting part/winding of the transformer. Earth is connected to the insulating part of the transformer. Guard is used to isolate the all other conducting part/materials under test.