

**Fifth Semester B.E. Degree Examination, July/August 2022**  
**Analysis of Indeterminate Structures**

Max. Marks: 100

**Note: Answer any FIVE full questions, choosing ONE full question from each module.**

**Module-1**

- 1 Analyse the continuous beam shear in Fig Q1 by slope deflection method. Take  $EI = 15000\text{kN-m}^2$ , support 'B' sinks by 8mm, sketch BMD.

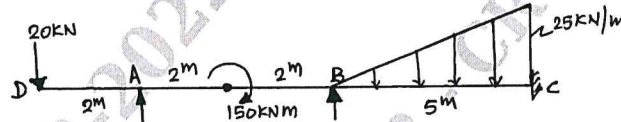

Fig Q1

(20 Marks)

OR

- 2 A portal frame in loaded as shown in Fig Q2. Analyze the frame by slope Deflection method sketch BMD.

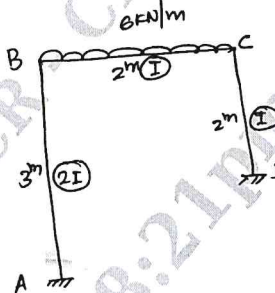

Fig Q2

(20 Marks)

**Module-2**

- 3 Analyse the continuous beam shown in Fig Q3 by moment Distribution method. The support 'C' sinks by 9mm Take  $EI = 1000\text{kN-m}^2$ .

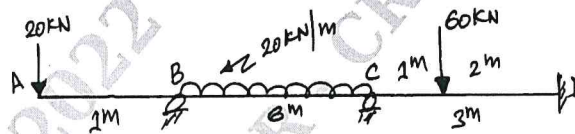

Fig Q3

(20 Marks)

OR

- 4 Analyse the Non sway rigid frame shown in Fig Q4 by moment distribution method, sketch BMD, EI is constant for all members.

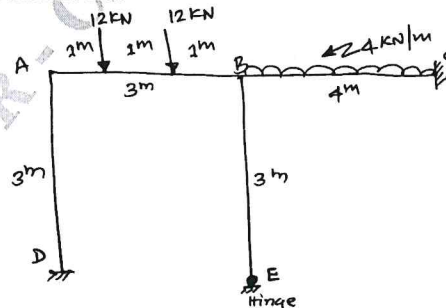

Fig Q4

(20 Marks)

Important Note : 1. On completing your answers, compulsorily draw diagonal cross lines on the remaining blank pages.  
 2. Any revealing of identification, appeal to evaluator and /or equations written eg, 42+8 = 50, will be treated as malpractice.

**Module-3**

- 5 Analyse the Non sway Rigid frame shown in Fig Q5 by KANI's Rotation method, sketch BMD. Assume EI constant for all members.

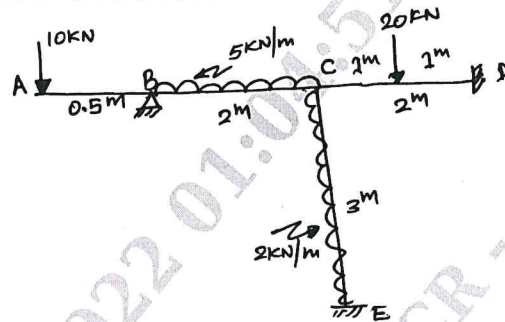

Fig Q5

(20 Marks)

OR

- 6 Analyse the frame shown in Fig Q6, by Kani's rotation method, sketch BMD.

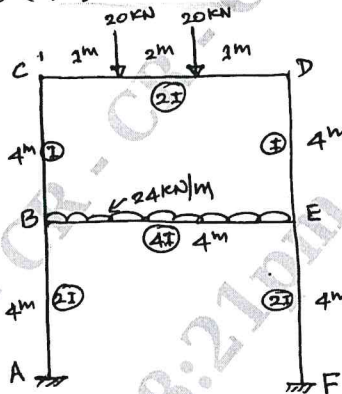

Fig Q6

(20 Marks)

**Module-4**

- 7 Using Flexibility Matrix Method, analyse the beam shown in Fig Q7. Sketch BMD, Assume EI constant.

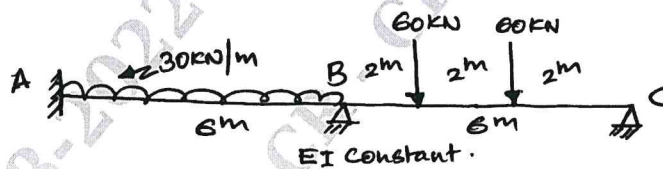

Fig Q7

(20 Marks)

OR

- 8 Analyse the continuous beam shown in Fig Q8, by using flexibility matrix method, sketch BMD.

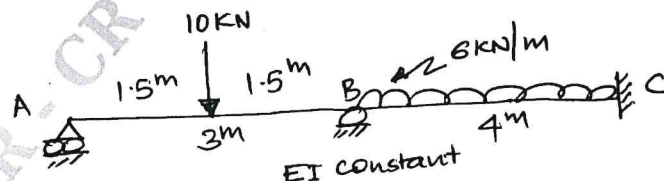

Fig Q8

(20 Marks)

**Module-5**

- 9 Analyse the continuous beam shown in Fig Q9, by stiffness matrix method. Assume EI constant sketch BMD.

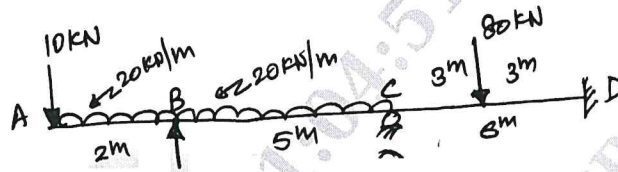

Fig Q9

(20 Marks)

OR

- 10 Analyse the rigid Non sway frame by Stiffness Matrix Method shown in Fig Q10, EI constant for all members.

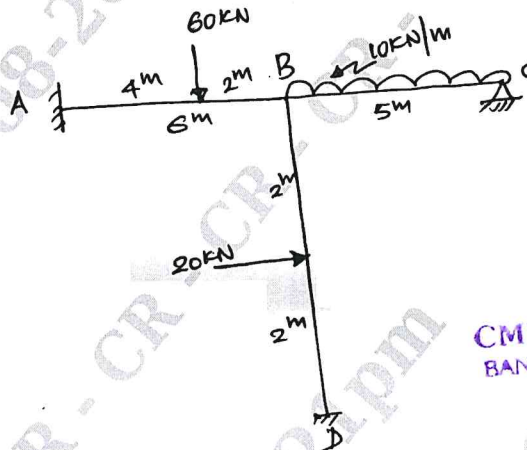

Fig Q10

(20 Marks)

\*\*\*\*\*