

# CBCS SCHEME

17CIV13/23

USN

--	--	--	--	--	--	--	--

## First / Second Semester B.E. Degree Examination, June/July 2023 Elements of Civil Engineering and Engineering Mechanics

Time: 3 hrs.

Max. Marks: 100

**Note:** Answer any FIVE full questions, choosing ONE full question from each module.

### Module-1

- 1 a. Explain the scope of the following fields of Civil Engineering (08 Marks)
  - i) Structural Engineering
  - ii) Geotechnical Engineering
  - iii) Transportation Engineering
  - iv) Water Resources and Irrigation Engineering.
- b. State and explain basic idealization of Mechanics. Also state the characteristics of force. (06 Marks)
- c. Find the angle of Force 200N shown in Fig. Q1(c), for minimum moment and maximum moment about point 'C'. (06 Marks)

Fig. Q1(c)

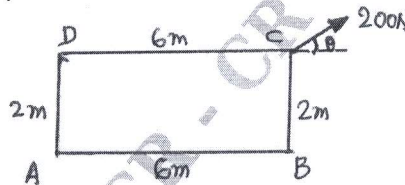

OR

- 2 a. State the effect of the infrastructural facilities on socio – economic development of a Country. (06 Marks)
- b. State and explain different types of classification of dams with examples. (06 Marks)
- c. Find equivalent force through point A and B for the forces shown in Fig. Q2(c). (08 Marks)

Fig. Q2(c)

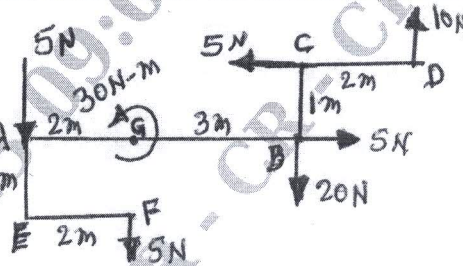

### Module-2

- 3 a. State and explain Parallelogram Law of Forces. (06 Marks)
- b. Find Resultant force with magnitude and direction for the system shown in Fig. 3(b). (06 Marks)

Fig. Q3(b)

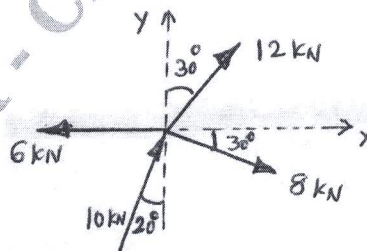

Important Note : 1. On completing your answers, compulsorily draw diagonal cross lines on the remaining blank pages.  
2. Any revealing of identification, appeal to evaluator and /or equations written eg, 42+8 = 50, will be treated as malpractice.

- c. Find tension in the strings for the system shown in Fig. Q3(c). Also find  $W_2$  if  $W_1 = 30\text{kN}$ . (08 Marks)

Fig. Q3(c)

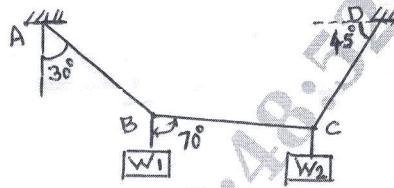

OR

- 4 a. Define i) Angle of Friction ii) Angle of Repose iii) Limiting friction. (06 Marks)  
 b. The Resultant of the given system of forces shown in Fig. Q4(b) in vertical. Find Resultant force magnitude and direction. (06 Marks)

Fig. Q4(b)

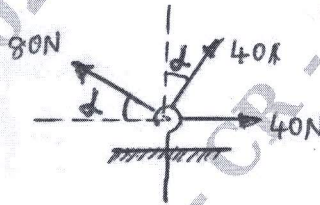

- c. Two cylinders of same size of 200mm diameter and weighs 1000N each placed in a groove shown in Fig. Q4(c). Find Reaction at surface of contacts. (08 Marks)

Fig. Q4(c)

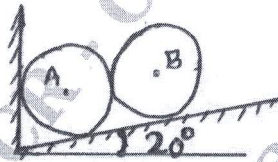

**Module-3**

- 5 a. State and prove Varignon's theorem. (06 Marks)  
 b. List the different types of supports with neat sketches. (04 Marks)  
 c. Determine the Magnitude, Direction and Position of Resultant force with respect to point 'A' shown in Fig. Q5(c). (10 Marks)

Fig. Q5(c)

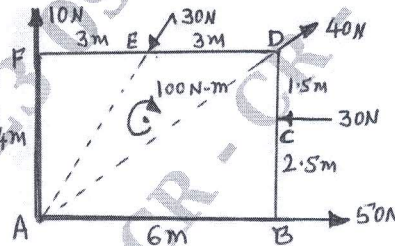

CMRIT LIBRARY  
BANGALORE - 560 037

OR

- 6 a. State the equilibrium conditions used for Coplanar Concurrent force system and Coplanar Non concurrent force system. (04 Marks)  
 b. State and explain different types of loads and types of beams with sketches. (06 Marks)  
 c. Find Support reactions for the beam shown in Fig. Q6(c). (10 Marks)

Fig. Q6(c)

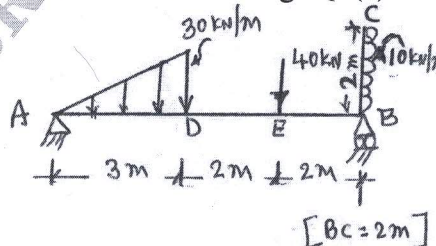



**Module-4**

- 7 a. State i) Parallel Axis theorem ii) Perpendicular Axis theorem. (04 Marks)  
 b. Determine Moment of Inertia of Semicircle about Horizontal diametrial axis from First principles. (06 Marks)  
 c. Locate the centroid of the Plane area shown in Fig. Q7(c) with respect to 'A'. (10 Marks)

Fig. Q7(c)

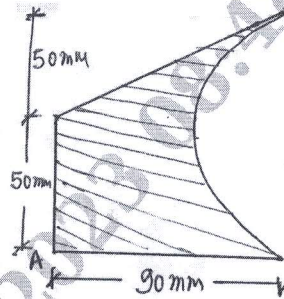

OR

- 8 a. Distinguish between Centroid and Centre of gravity. Also state the importance of centroid of plane areas. (04 Marks)  
 b. Determine the Centroid of a triangle of base B and Height 'H' about axis Passing through Base. (06 Marks)  
 c. Find Polar moment of Inertia of the plane area shown in Fig.Q8(c) about reference axis shown. Also find Polar radius of gyration. (10 Marks)

Fig. Q8(c)

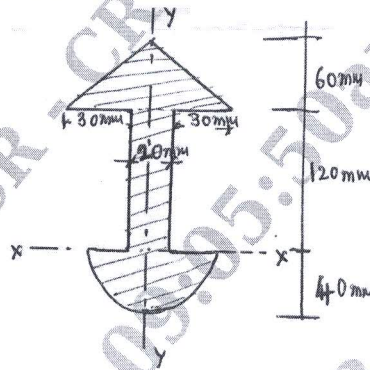

CMRIT LIBRARY  
 BANGALORE - 560 037

**Module-5**

- 9 a. Define : i) Displacement ii) Velocity iii) Acceleration iv) Speed (06 Marks)  
 v) Centrifugal force vi) Angle of Projection. (04 Marks)  
 b. What is Super Elevation and why it is provided?  
 c. A bullet moving at the rate of 250m/sec is fired into a log of wood. The bullet penetrates to a depth of 400mm. If the bullet moving with same velocity is fired into a similar piece of wood 200mm thick, with what velocity bullet emerges out. (10 Marks)

OR

- 10 a. Derive the equations of Linear motion. (06 Marks)  
 b. The equation of motion of particle is given by  $a = 4t^3 - 3t^2 + 6$ . The velocity of particle at time 1.0 second is 5.0m/sec and displacement is 10m. Determine displacement and velocity at time 5.0 seconds. (06 Marks)  
 c. A bullet fired upwards at an angle of  $30^\circ$  to the horizontal with a velocity of 100m/sec from the top of tower of height 80m. Find i) Velocity with which bullet strikes the target ii) Total time required for the flight of the bullet. (08 Marks)

\* \* \* \* \*