

USN

--	--	--	--	--	--	--	--	--	--	--	--	--	--	--	--	--	--	--	--



Internal Assessment Test 2 – May 2023

Sub:	Nontraditional machining					Sub Code:	18ME64	Branch:	ME		
Date:	24.05.2023	Duration:	1.30 hour	Max Marks:	50	Sem / Sec:	VI/A			OBE	
<u>Answer any FIVE Questions</u>								MARKS		CO	RB T
1	Explain briefly the tooling techniques in electro chemical machining process.					[10]			CO3	L2	
2	Explain with neat sketch the working of Electro chemical honing machining process.					[10]			CO3	L2	
3	Explain with neat flow chart the working of Chemical milling process and also mention its advantages and disadvantages.					[10]			CO3	L2	
4	Explain with neat sketch the working of Electro chemical machining process and also mention its advantages and disadvantages.					[10]			CO3	L2	
5	Explain how the following parameters with respect to chemical blanking process (1) Type of etchants (2) Type of maskants (3) Material removal rate (4) Accuracy.					[10]			CO3	L2	
6	Explain with neat sketch the working of Electro chemical grinding and also mention its advantages and disadvantages					[10]			CO3	L2	

CI

CCI

HoD

1. Tooling Techniques in ECM

The figure 1 shows a simple round tool. The leading edge is sharp and the shank is not insulated. This type of tool produces a hole with considerable amount of taper because the complete surface area of the hole produced is being constantly machined.

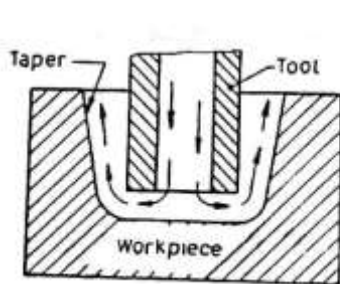

Figure 1

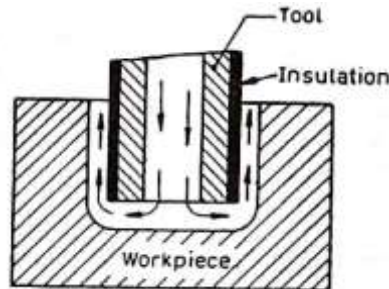

Figure 2

The figure 2 shows the same tool with insulation on the sides. This limits ECM action extending from the tip of the tool to the top of the hole, and no significant taper is produced. This type of tool is still quite apt to produce striations because the electrolyte tends to become turbulent as it passes around the sharp corners. This will have an adverse effect on the ability to hold tolerances and surface finish, as well encourage arcing and possible shorting at the corners of the tool.

The figure 3 shows a tool with its leading edge radiused to encourage uniform electrolyte flow around the corner, also a tip brased on the shank of the tool allows easy replacement and use of materials such as tungsten and copper to prevent damage in the event of arcing.

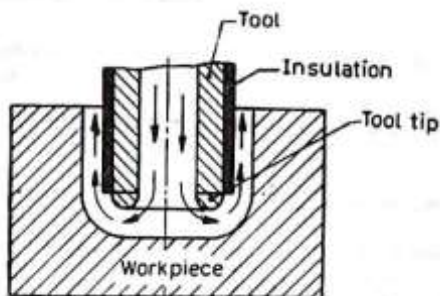

Figure 3

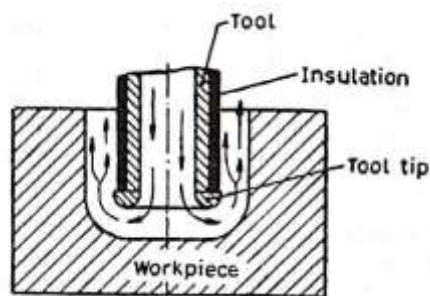

Figure 4

The figure 4 shows yet another improvement that has proved effective in eliminating any significant taper encountered in the previous methods. The overlap of the tip causes the electrolyte flow to break up as is passed around the radiused corner. This minimizes the effect of any stray currents which are likely to cause additional machining over the already finished surfaces.

The figure 5 shows a tool which has its tip flush with the main body and insulation. The electrolyte flow is reversed. This technique produces hole with minimum taper and excellent finish.

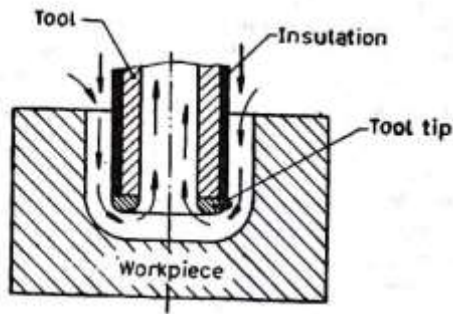
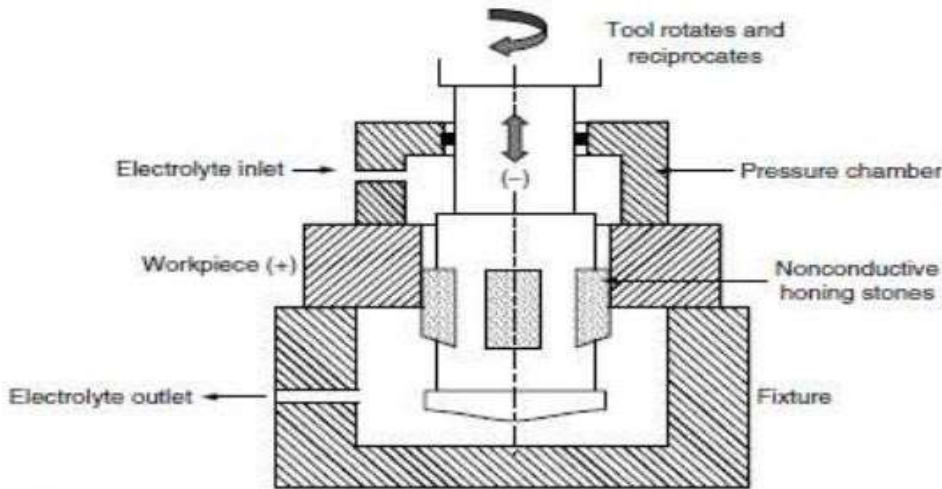

Figure 5

2. Electrochemical Honing



It is a process in which it combines the high removal characteristics of Electrochemical Dissolution (ECD) and Mechanical Abrasion (MA) of conventional Honing. It has much higher rates than either of honing & internal cylindrical grinding. Cathodic tool is similar to the conventional honing tool, with several rows of small holes so that electrolyte could enter directly into inter electrode gap. Electrolyte provides electron through the ionization process which acts as coolant and flushes away the chips that are formed off by mechanical abrasion and metal sludge that results from electrochemical dissolution action. Tool is inserted inside the worked hole or a cylinder. • Mechanical abrasion takes place first by the stones/hones. Oxides formed due to working from previous process will be removed by it and clean surface will be achieved. Now the clean surface will be in contact with electrolyte and then Electrochemical Dissolution will remove the desired material. Same procedure is continued till the required cut is made. To control surface roughness Mechanical Abrasion is allowed to continue for a few seconds after the current has been turned off.

Applications

- Due to rotating and reciprocating honing motion, the process reduces the errors in roundness through the rotary motion.
- Taper and waviness errors can also be reduced

Advantages

- Low tolerances.
- Good surface finish is achieved.
- Small Correction on work pieces is possible.
- Shaping and surface finishing is done in one process.
- Light stone/hone pressure is used in the process, heat distortion is avoided.

- Due to Electrochemical Dissolution phase, no stress is accumulated and it automatically deburrs the part.
- It can be used for hard and conductive material that are susceptible to heat and distortion.

Disadvantages

- Machinery cost is high.
- Machining cost per piece increases as it is an addition process.

3. Chemical Milling (CHM) is the controlled chemical dissolution (CD) of the work piece material by contact with a strong reagent Used to produce pockets & contours.

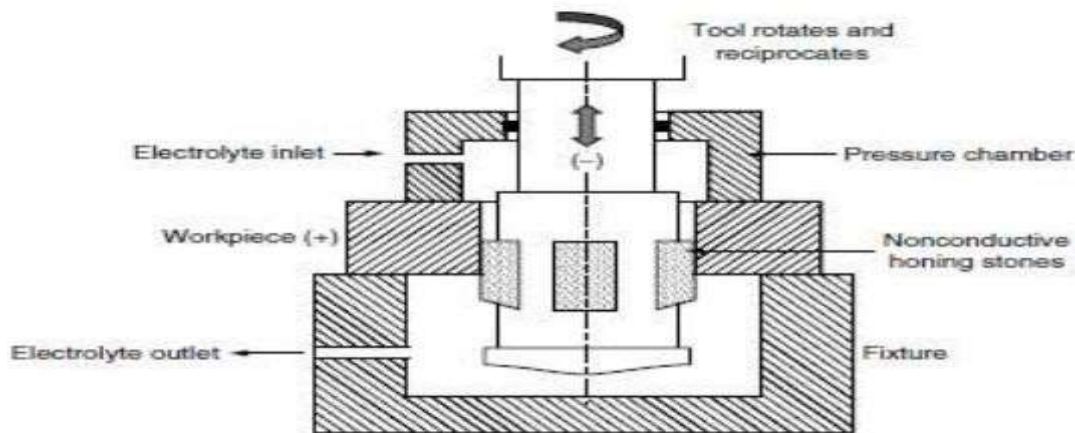

CHM consists of following steps-

- Preparing and pre cleaning the work piece surface.
- Masking using readily strippable mask
- Scribing of the mask, guided by templates
- The work piece Is then etched and rinsed

Etchants are acid or alkaline solutions maintained within a controlled range of chemical composition and temperature. Main technical goals of etchants are- Good surface finish, Uniformity of metal removal, Maintenance of air quality and avoid the environmental problems and ability to regenerate the etchant solution.

Advantages

- Weight reduction is possible on complex contours that are difficult to machine using conventional methods.
- No burrs are found.
- Design changes can be implemented quickly.
- A less skilled operator is needed.
- Simultaneous material removal, from all surfaces, improves productivity and reduces wrapping.

Limitations

- Handling and disposal of chemicals can be troublesome.
- Surface imperfections are reproduced in the machined parts.
- Deep narrow cuts are difficult to produce.
- Porous castings yield uneven etched surfaces.

- Material removal from one side of residually stressed material can result in a considerable distortion. Welded areas frequently etch at rates that differ from base metal.

Applications

- CHM applications range from large aluminum alloy airplane wing parts to minute integrates chips.
- CHM is used to thin out walls, webs, and ribs of parts that have been produced by forging, casting, or sheet metal forming
- Shallow cuts in large thin sheets are the most popular application especially for weight reduction of aerospace components
- Removal of sharp burrs from conventionally machined parts of complex shapes.
- Elimination of the decarburized layer from low alloy steel forgings.

4. Electrochemical Machining

Electrochemical machining works on the Faraday law of electrolysis which state that if two electrode are placed in a container which is filled with a conductive liquid or electrolyte and high ampere DC voltage applied across them, metal can be depleted form the anode (Positive terminal) and plated on the cathode (Negative terminal). This is the basic principle of electrochemical machining. In this machining process, tool is connected with the negative terminal of battery (work as cathode) and work-piece is connected with the positive terminal of battery (work as anode). They both are placed in a electrolyte solution with a small distance. When the DC current supplied to the electrode, metal removed from work-piece. This is basic fundamental of electrochemical machining.

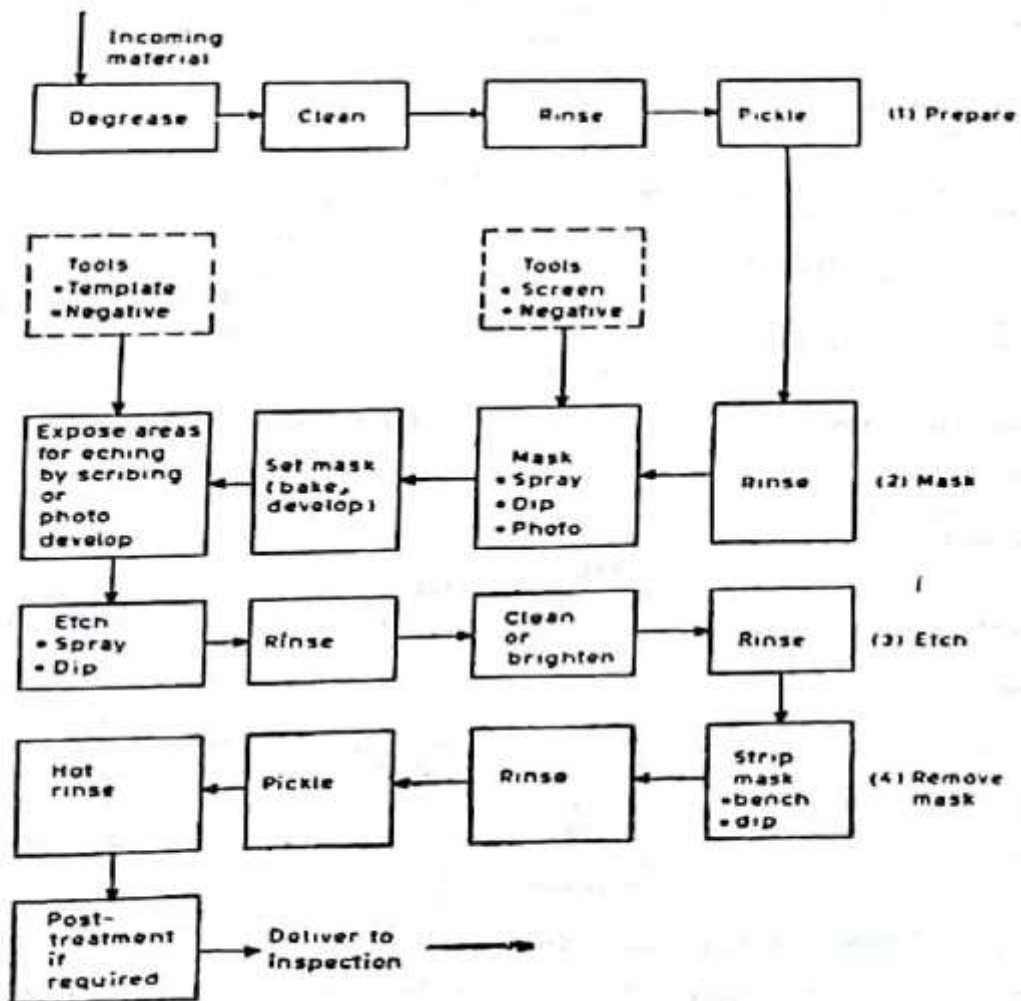

Working of Electrochemical Machining:

Electrochemical machining works inverse as electroplating process. Metal is removed from anode into electrolyte and convert into slag form by reacting opposite ions available in electrolyte. This process works as follow.

- In ECM, the electrolyte is so chosen that there is no plating on tool and shape of tool remain unchanged. Generally NaCl into water takes as electrolyte.
- The tool is connected to negative terminal and work is connected to positive terminal.
- When the current passes through electrode, reaction occur at anode or work piece and at the cathode or tool. To understand proper working let's take an example of machining low carbon steel.
- Due to potential difference ionic dissociation take place in electrolyte.
- When the potential difference applied between the work piece and tool, positive ions move towards the tool and negative ions towards the work piece.
- Thus the hydrogen ion moves towards tool. As the hydrogen reaches to the tool, it takes some electron from it and converts into gas form. This gas goes into environment.
- When the hydrogen ions take electron from tool, it creates lack of electron in mixture. To compensate it, ferrous ions created at the work piece (anode) which gives equal amount of electron in mixture.
- These Ferrous ions react with opposite chlorine ions or hydroxyl ions and get precipitate in form of sludge.
- This will give ferrous or iron into electrolyte and complete the machining process. This machining process gives higher surface finish because machining is done atom by atom.

Application:

- ECM is used to machining disk or turbine rotor blade.
- It can be used for slotting very thin walled collets.
- ECM can be used to generate internal profile of internal cam.
- Production of satellite rings and connecting rod, machining of gears and long profile etc.

Advantages:

- It can machine very complicated surface.
- A single tool can be used to machining large number of work-piece. Theoretically no tool wear occur.
- Machining of metal is independent on strength and hardness of tool.
- ECM gives very high surface finish.

Disadvantages:

- High initial cost of machine.
- Design and tooling system is complex.
- Fatigue property of machined surface may reduce.
- Nonconductive material cannot be machined.
- Blind hole cannot be machined form ECM.
- Space and floor area requirement is high compare to conventional machining.

5. Type of etchants:

Purpose: To dissolve a metal by turning it into a metallic salt, this then goes into solution

Many chemical are available as etchants: FeCl_3 , Chromic acid, FeNO_3 , HF, HNO_3 .

Etchant selection is based on various criteria i.e. required surface finish, removal rate, material type, Etch depth, type of resist and cost of Etchant.

Type of Maskants:

Three major categories of chemically resistant masks are available for use in chemical machining • Selection of proper maskant for a particular application is accomplished by evaluation of the job with respect to six factors – chemical resistance, part configuration, quantity of parts, cost, ease of removal and required resolution

Classification of maskants • Cut and peel • Screen printing • Photoresist masks

Material removal rate:

It is chiefly dependent on the selected etchant, however etchants that remove the metal faster tend to have many side effects including (i) reduction in surface finish (ii) increased undercutting (iii) higher heating (iv) greater change of etch rate with temperature and (v) attack on bond between the maskant and the workpiece. The etch rate is generally limited to 0.02-0.04 mm/min. Where surface finish and accuracy are not important.

Accuracy:

The chief disadvantage of chemical blanking is undercutting. Undercutting refers only to attack just below the resist edge on one side of the cut this is defined by the etch factor which is the ratio of depth of cut to the undercut. Generally a tolerance of 10% of sheet thickness can be held in thin sheets. The best tolerance that can be achieved by this process is about ± 0.02 mm.

6. Electrochemical grinding (ECG) -

The process is similar to cathode is a specially constructed grinding wheel instead of a cathodic shaped. The insulating abrasive material (diamond or aluminum oxide) of the grinding wheel is set in conductive bonding, the wheel is a rotating cathodic tool with abrasive particles on its periphery. Electrolyte flow, usually NaNO_3 , is provided for ECD (Electro chemical dissolution). Similar to ECM except that the cathode is a specially constructed grinding of a cathodic shaped tool. The insulating abrasive material (diamond or the grinding wheel is set in a conductive bonding material. the wheel is a rotating cathodic tool with abrasive particles on its periphery. Electrolyte flow, usually NaNO_3 , is provided for ECD.

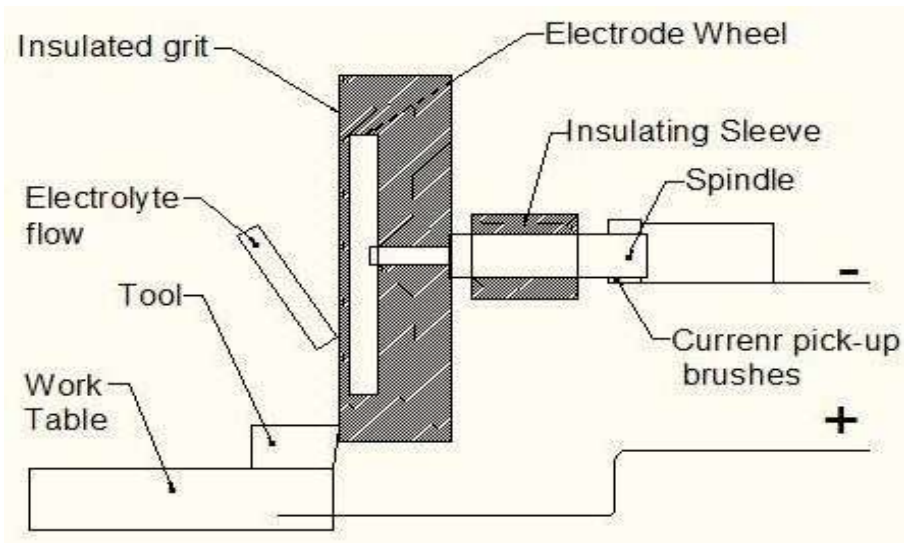

Working Principle

The wheel rotates at a surface m/s, while current ratings when a gap voltage of between the cathodic anodic work piece, a current to 240 A/cm² is created. The current density depends on the material being machined, the gap width, and the applied voltage surface speed of 20 to 35 ratings are from 50 to 300 A. of 4 to 40 V is applied grinding wheel and the current density of about 120. The current density depends on the material, the gap width, and the applied voltage.

Applications

- Machining parts made from difficult such as sintered carbides, creep-resisting (Inconel titanium alloys, and metallic composites. • Applications similar to milling, grinding, cutting off, sawing, and tool and cutter sharpening.
- Production of tungsten carbide cutting tools, fragile parts, and thin walled tubes.
- Producing specimens for metal fatigue and tensile tests.
- Machining of carbides and a variety of high alloys.

Advantages

- Absence of work hardening
- Elimination of grinding burrs
- Absence of distortion of thin fragile or thermosensitive parts
- Good surface quality • Production of narrow tolerances
- Longer grinding wheel

Disadvantages

- Higher capital cost than conventional machines.
- Process limited to electrically conductive materials.
- Corrosive nature of electrolyte.
- Requires disposal and filtering of electrolyte
- Disadvantages
- Higher capital cost than conventional
- Process limited to electrically conductive
- Corrosive nature of electrolyte
- Requires disposal and filtering of electrolyte

