

CBCS SCHEME

18ME52

Fifth Semester B.E. Degree Examination, June/July 2023 Design of Machine Elements – I

Time: 3 hrs.

Max. Marks: 100

Note: Answer any FIVE full questions, choosing ONE full question from each module.

Module-1

- 1 a. What are the factors to be considered for the selection for a machine component? (06 Marks)
- b. Explain the codes and standards used in Machine Design. (04 Marks)
- c. A point in a structural member subjected to a plane stress as shown in Fig.Q1(c). Determine the following :
 - i) Normal and Tangential stress on a plane inclined at 45° .
 - ii) Principal stresses and their direction
 - iii) Maximum shear stress and the direction of the plane on which it occurs.

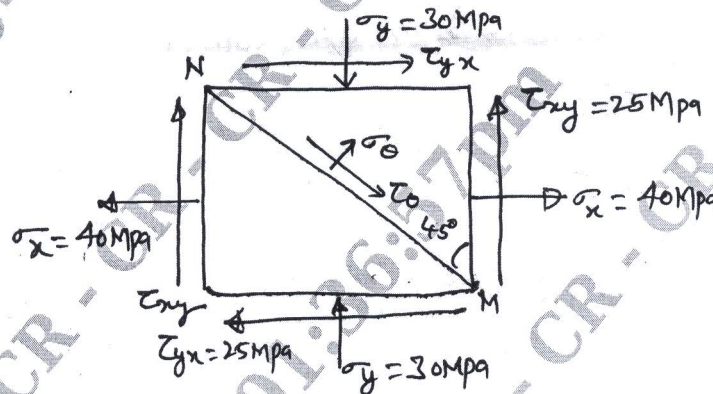

Fig.Q1(c)

(10 Marks)

OR

- 2 a. Define stress concentration factor and discuss about the methods to reduce stress concentration factor. (08 Marks)
- b. A circular rod shaft of diameter of 50mm is subjected to load as shown in Fig.Q2(b). Determine the nature and magnitude of stresses at the critical points A and B.

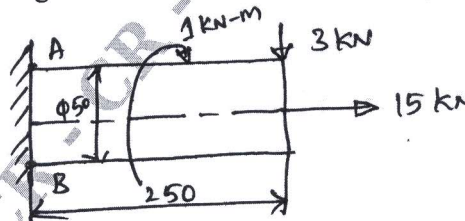

Fig.Q2(b)

(12 Marks)

Module-2

- 3 a. Define Impact Stresses. Derive an expression for impact stresses in a axial bar of c/s 'A' and length 'L' due to the impact load of 'W' falling from a height 'h' from the collar. (08 Marks)

Important Note : 1. On completing your answers, compulsorily draw diagonal cross lines on the remaining blank pages.
2. Any revealing of identification, appeal to evaluator and /or equations written eg, 42+8 = 50, will be treated as malpractice.

- b. A cantilever beam made of cold drawn carbon steel ($\sigma_u = 550$ MPa, $\sigma_y = 470$ MPa, $\sigma_{-1} = 275$ MPa) of circular cross-section is subjected to load which varies from $-F$ to $3F$. Determine the maximum load that this member can withstand for an infinite life using a factor of safety of 2. [Refer Fig.Q3(b)] (12 Marks)

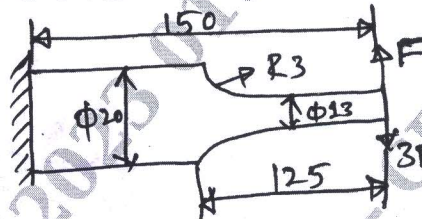

Fig.Q3(b)

OR

- 4 a. Define Endurance limit. Explain the effect of factors on Endurance limit. (08 Marks)
 b. A hot rolled steel shaft is subjected to a torsional load that varies from 330 N-m (CW) to 110 Nm (CCW) as an applied bending moment at the critical section varies from +440 N-m to -220 Nm. The shaft is of uniform cross section and no key way is present at the critical section. Determine the required shaft diameter. The material has an ultimate strength of 550 MN/m² and yield strength of 410 MN/m². Factor of safety = 1.5 size and surface correction are 0.85 and 0.62 respectively. Take the Endurance limit as half the ultimate strength. (12 Marks)

Module-3

- 5 A shaft is supported by two bearings placed 1m apart. A 500mm diameter pulley is mounted at a distance of 200mm to the right of left hand bearing and this drives a pulley directly below it with the help of belt having maximum tension of 3000N. The pulley weighs 1000N. Another pulley 300mm diameter is placed 300mm to the left of right hand bearing is driven with the help of electric motor and the belt which is placed horizontally to the right when viewed from the left bearing. This pulley weighs 500 N. The angle of contact for both the pulley is 180° and $\mu = 0.24$. Determine suitable diameter for a solid shaft, assuming torque on one pulley is equal to torque on other pulley. Choose C15 steel ($\sigma_y = 235.4$ MPa, $\sigma_u = 425$ MPa) as the shaft material and use ASME code for the design of shaft, assume minor shock condition. (20 Marks)

OR

- 6 a. With neat sketch, explain the different types of keys. (08 Marks)
 b. Design a flange coupling to connect the shafts of a motor and the centrifugal pump for the following specifications:
 Pump output = 3000 liters/minute
 Total head = 20 m
 Pump speed = 600 rpm
 Pump Efficiency = 70%
 Select C-40 steel ($\sigma_y = 328.6$ MPa) for the shaft and C-35 steel ($\sigma_y = 304$ MPa) for bolts with factor of safety 2. Use allowable shear stress in cast iron flanges equal to 15 N/mm². (12 Marks)

CMRIT LIBRARY
 BANGALORE - 560 037

Module-4

- 7 a. Design a triple riveted Lap Zig-Zag type, for a pressure vessel of 1.5m diameter. The maximum pressure inside the vessel is 1.5 MPa. The allowable stresses in tension, crushing and shear are 100, 125 and 75 MPa respectively. (10 Marks)
- b. A bracket is supported by means of 4 rivets of same size as shown in Fig.Q7(b). Determine the diameter of rivet, if the maximum shear stress is 140 N/mm^2 .

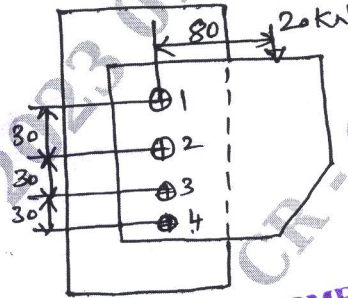

Fig.Q7(b)

CMRIT LIBRARY
BANGALORE - 560 037

(10 Marks)

OR

- 8 a. A plate of 80mm wide and 10mm thick is to be welded to another plate by means of two parallel fillet welds. The plates are subjected to a load of 50 kN. Find the length of weld so that maximum stress does not exceed 50 N/mm^2 . Consider the joint under static loading and then under dynamic loading. (12 Marks)
- b. A solid circular shaft 25mm in diameter is welded to a support by means of a fillet weld as shown in Fig.Q8(b). Determine the Leg dimensions of the weld, if the permissible shear stress is 95 N/mm^2 .

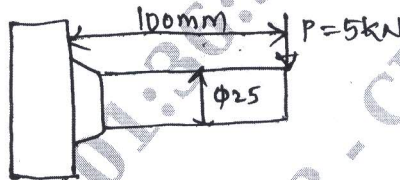

Fig.Q8(b)

(08 Marks)

Module-5

- 9 a. Design a socket and spigot type cotter joint to sustain an axial load of 100 kN. The material selected for the joint has the following design stresses $\sigma_f = 100 \text{ N/mm}^2$, $\sigma_c = 150 \text{ N/mm}^2$ and $\tau = 60 \text{ N/mm}^2$. (14 Marks)
- b. Explain self locking and over hauling in power screws. (06 Marks)

OR

- 10 a. Derive an equation for torque required to lift the load on square threaded screw. (10 Marks)
- b. A split nut used with a lead screw is propelled at a speed of 5 m/min, against a load of 20 kN, along the spindle of a square thread (single start) having nominal diameter of 30mm and pitch of 6mm. The axial thrust is absorbed by collar of 100mm outside diameter and 70mm insides diameter. Determine, (i) Power required (ii) Height of bronze nut required if allowable bearing pressure is 17 MPa. (iii) Efficiency of the drive. (10 Marks)
