

USN

Third Semester B.E./B.Tech. Degree Examination, Dec.2023/Jan.2024

Electronic Principles and Circuits

Max. Marks: 100

Note: 1. Answer any FIVE full questions, choosing ONE full question from each module.

2. M : Marks , L: Bloom's level , C: Course outcomes.

Module – 1			M	L	C
Q.1	a.	Explain the simplified analysis of a voltage divider bias circuit of a transistor. Also list the steps in analysis.	8	L1	CO1
	b.	Analyze a VDB Amplifier circuit with respect to DC circuit, AC - π model, AC - T model.	7	L3	CO1
	c.	Design a positive and negative biased clipper circuit.	5	L3	CO1
OR					
Q.2	a.	With the importance of Coupling capacitor, explain the Base – Biased amplifier circuit. Support your answer with base current , collector current and collector voltage. Also draw its voltage waveforms.	10	L3	CO1
	b.	Explain the basic idea of Common – Collector (CC) amplifier. Give the mathematical relation of AC. Emitter resistance (r_e) , Voltage Gain (A_v) , Input impedance of the base ($Z_{in(base)}$) and Input impedance of the stage ($Z_{in(stage)}$).	6	L2	CO1
	c.	Calculate the output impedance for the circuit below, given $V_{BQ} = 15V$.	4	L2	CO1
<div style="display: flex; align-items: center; justify-content: center;"> <div style="margin-right: 10px;">Fig. Q2(c)</div> </div>					
Module – 2					
Q.3	a.	Biasing by fixing V_{GS} is not a good approach to bias a MOSFET. Why? Explain biasing by fixing V_G and connecting a resistance in the source for MOSFET.	8	L2	CO2
	b.	Design a fixed V_G and resistance in the source biasing circuit, to establish drain current $I_D = 0.5mA$, $V_t = 1V$, $K_n' W/K = 1mA/V^2$, $\lambda = 0$. Use power supply $V_{DD} = 15V$.	5	L3	CO2
	c.	Obtain the transfer and drain characteristics of n – channel MOSFET and calculate Drain resistance (r_d) , Mutual conductance (g_m) and Amplification factor (μ).	7	L2	CO2
OR					
Q.4	a.	Illustrate the development of T – equivalent circuit model for the MOSFET.	6	L2	CO2

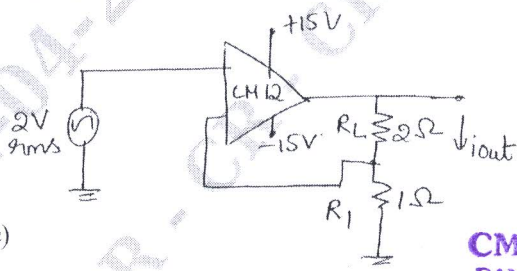
	b.	Draw and explain the small signal equivalent model for Common – Source amplifier without source resistance and write the equation for R_{in} , R_{out} , A_v and G_v .	8	L2	CO2
	c.	For a Common Gate (CG) amplifier circuit, given $g_m = 1\text{mA/V}$, $R_D = 15\text{k}\Omega$, $R_L = 15\text{k}\Omega$, $R_{sig} = 50\Omega$, $R_G = 4.7\mu\Omega$. Find R_{in} , R_{out} , A_{VO} , A_v and G_v .	6	L2	CO2
Module – 3					
Q.5	a.	Explain how an Op – amp summer circuit be configured to function as a subtractor.	5	L1	CO3
	b.	How does the design and configuration of an Op – amp R/2R DAC contribute to its accuracy and performance in converting digital signals to analog signals?	8	L2	CO3
	c.	Design and draw the frequency response of common source JFET / MOSFET amplifier.	7	L2	CO3
OR					
Q.6	a.	Describe the working of inverting Schmitt trigger circuit. How is Schmitt trigger different from regular comparator circuit? Explain with the help of Hysteresis curve.	8	L2	CO3
	b.	Explain the working of Colpitts Oscillator with CE connection.	6	L2	CO3
	c.	Explain the Monostable operation of 555 timers.	6	L2	CO3
Module – 4					
Q.7	a.	Explain the four types of Negative feedback amplifier.	8	L1	CO4
	b.	Explain the VCVS amplifier. Obtain its exact closed – loop voltage gain and Ideal Closed – Loop Voltage gain. Also define Gain stability, Closed loop input impedance and Closed loop output impedance of a VCVS amplifier.	8	L2	CO4
	c.	Calculate the load power, load current for the given VCIS amplifier circuit.	4	L2	CO4
		 <p>Fig. Q7(c)</p> <p style="text-align: right;">CMRIT LIBRARY BANGALORE - 560 037</p>			
OR					
Q.8	a.	Explain the Ideal response of filters.	8	L1	CO4

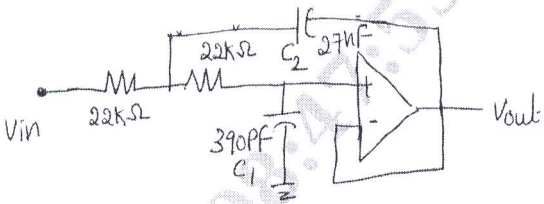
	<p>b. Determine the pole frequency, Q, Cutoff frequency and 3-dB frequency, for the filter circuit given below :</p> <p>Fig. Q8(b)</p>  <p>Given $K_0 = 0.99$, $K_C = 1.38$, $K_3 = 1.54$.</p>	5	L2	CO4
	<p>c. Design a Halfwave and Fullwave precision rectifier using Op-amp.</p>	7	L3	CO4

Module – 5

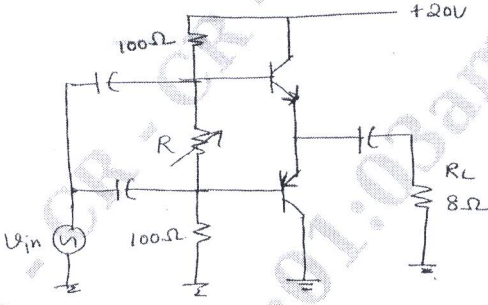
Q.9	<p>a. Explain class A amplifier, interns of its power gain, Output power, Power dissipation and efficiency.</p>	8	L1	CO5
	<p>b. Explain class B push pull emitter follower amplifier. How can the crossover distortion be eliminated?</p>	8	L1	CO5
	<p>c. Calculate the maximum transistor power dissipation and maximum output power for the given circuit.</p> <p>Fig. Q9(c)</p> 	4	L2	CO5

OR

Q.10	<p>a. What is an SCR? With the help of basic SCR circuit, explain the gate triggering.</p>	6	L1	CO5
	<p>b. Explain the phase control method of TRIAC, along with the voltage waveforms.</p>	7	L1	CO5
	<p>c. Design a full wave controlled rectifier circuit using RC triggering.</p>	7	L3	CO5
