

**Question with Solutions**

**Module 1**

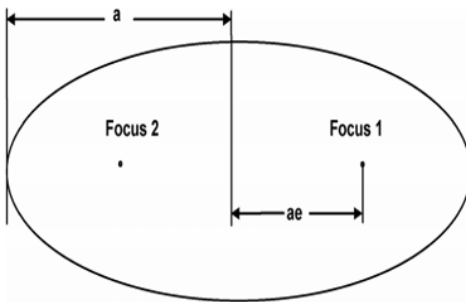
**Q.1a Explain Kepler laws of Planetary motion. Also derive the expression for orbital period.**

**Answer:**

**Kepler's First Law**

1. The orbit of a satellite around Earth is elliptical with the centre of the Earth lying at one of the foci of the ellipse.
2. Eccentricity ( $e$ ) is the ratio of the distance between the centre of the ellipse and either of its foci ( $= ae$ ) to the semi-major axis of the ellipse  $a$ .

*The law of conservation of energy is valid at all points on the orbit.*



**Fig: Kepler's first law**

In the context of satellites, it means that the sum of the kinetic and the potential energy of a satellite always remain constant. The value of this constant is equal to  $-Gm_1m_2/(2a)$ , where

$m_1$  = mass of Earth

$m_2$  = mass of the satellite

$a$  = semi-major axis of the orbit

$$\text{Kinetic energy} = \frac{1}{2}(m_2v^2)$$

$$\text{Potential energy} = -\frac{Gm_1m_2}{r}$$

$$\frac{1}{2}(m_2v^2) - \frac{Gm_1m_2}{r} = -\frac{Gm_1m_2}{2a}$$

$$v^2 = Gm_1 \left( \frac{2}{r} - \frac{1}{a} \right)$$

$$v = \sqrt{\left[ \mu \left( \frac{2}{r} - \frac{1}{a} \right) \right]}$$

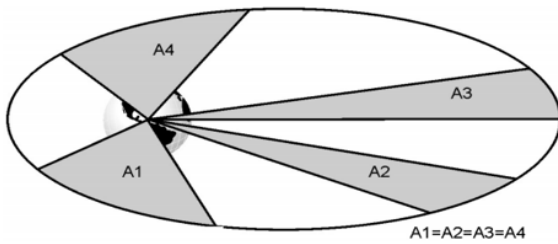
### Kepler's Second Law

The line joining the satellite and the centre of the Earth sweeps out equal areas in the plane of the orbit in equal time intervals

i.e. the rate ( $dA/dt$ ) at which it sweeps area  $A$  is constant.

The rate of change of the swept-out area is given by

$$\frac{dA}{dt} = \frac{\text{angular momentum of the satellite}}{2m}$$



### Kepler's Third Law

- ❖ The square of the time period of any satellite is proportional to the cube of the semi-major axis of its elliptical orbit.
- ❖ A circular orbit with radius  $r$  is assumed.
- ❖ A circular orbit is only a special case of an elliptical orbit with both the semi-major axis and semi-minor axis equal to the radius.

Equating the gravitational force with the centrifugal force gives

$$\frac{Gm_1m_2}{r^2} = \frac{m_2v^2}{r}$$

Replacing  $v$  by  $\omega r$  in the above equation gives

$$\frac{Gm_1m_2}{r^2} = \frac{m_2\omega^2r^2}{r} = m_2\omega^2r$$

which gives  $\omega^2 = Gm_1/r^3$ . Substituting  $\omega = 2\pi/T$  gives

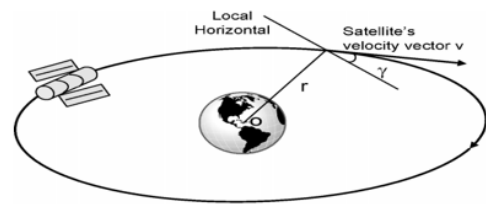
$$T^2 = \left(\frac{4\pi^2}{Gm_1}\right)r^3$$

This can also be written as

$$T = \left(\frac{2\pi}{\sqrt{\mu}}\right)r^{3/2}$$

**To derive the orbital equation for a satellite, we can start from Newton's law of gravitation and Newton's second law of motion. These laws provide a foundation for understanding how gravitational forces govern satellite motion. Here's a step-by-step derivation:**

Fig: Satellite's position at any given time



Kepler's second law is also equivalent to the law of conservation of momentum, which implies that the angular momentum of the orbiting satellite given by the product of the radius vector and the component of linear momentum perpendicular to the radius vector is constant at all points on the orbit.

$$v_p r_p = v_a r_a = v r \cos \gamma$$

where

$v_p$  = velocity at the perigee point

$r_p$  = perigee distance

$v_a$  = velocity at the apogee point

$r_a$  = apogee distance

$v$  = satellite velocity at any point in the orbit

$r$  = distance of the point

$\gamma$  = angle between the direction of motion of the satellite and the local horizontal

The above equation holds good for elliptical orbits provided  $r$  is replaced by the semi-major axis  $a$ . This gives the expression for the time period of an elliptical orbit as

$$T = \left(\frac{2\pi}{\sqrt{\mu}}\right)a^{3/2}$$

### Step 1: Newton's Law of Gravitation

Newton's Law of Gravitation states that the force of gravity  $F_g$  between two point masses is given by:

$$F_g = \frac{GMm}{r^2}$$

Where:

- $G$  is the gravitational constant,
- $M$  is the mass of the central body (e.g., Earth),
- $m$  is the mass of the satellite,
- $r$  is the distance between the center of the central body and the satellite.

### Step 2: Centripetal Force

For an object in circular orbit, the gravitational force provides the centripetal force required to keep the satellite in orbit. The centripetal force  $F_c$  needed to maintain an object in a circular orbit is given by:

$$F_c = \frac{mv^2}{r}$$

Where:

- $m$  is the mass of the satellite,
- $v$  is the orbital velocity of the satellite,
- $r$  is the radius of the orbit.

### Step 3: Equating the Forces

For a satellite in a stable orbit, the gravitational force provides the centripetal force. Therefore, we set  $F_g = F_c$ :

$$\frac{GMm}{r^2} = \frac{mv^2}{r}$$

Notice that the mass of the satellite  $m$  cancels out:

$$\frac{GM}{r^2} = \frac{v^2}{r}$$

Multiplying both sides of the equation by  $r$ :

$$\frac{GM}{r} = v^2$$

Thus, the orbital velocity  $v$  of the satellite is:

$$v = \sqrt{\frac{GM}{r}}$$

#### Step 4: Orbital Period

The orbital period  $T$  is the time it takes for the satellite to complete one full revolution around the central body. The distance traveled by the satellite in one orbit is the circumference of the orbit, given by:

$$\text{Circumference} = 2\pi r$$

Since the satellite moves with velocity  $v$ , the orbital period  $T$  is the time required to travel this distance:

$$T = \frac{\text{Circumference}}{v} = \frac{2\pi r}{v}$$

Substituting the expression for  $v$ :

$$T = \frac{2\pi r}{\sqrt{\frac{GM}{r}}}$$

Simplifying:

$$T = 2\pi \sqrt{\frac{r^3}{GM}}$$

Simplifying:

$$T = 2\pi \sqrt{\frac{r^3}{GM}}$$

Thus, the orbital period  $T$  is:

$$T = 2\pi \sqrt{\frac{r^3}{GM}}$$

#### Step 5: General Equation of Orbital Motion

In general, for elliptical orbits (according to Kepler's laws), the motion of the satellite can be described by the vis-viva equation, which is derived from energy conservation and Newton's laws:

$$v^2 = GM \left( \frac{2}{r} - \frac{1}{a} \right)$$

Where:

- $v$  is the orbital velocity,
- $r$  is the current distance from the center of the central body,
- $a$  is the semi-major axis of the elliptical orbit.

For circular orbits, where  $r = a$ , this simplifies to the previous expression for orbital velocity.

#### Conclusion

The expression for the orbital velocity of a satellite in a circular orbit is:

$$v = \sqrt{\frac{GM}{r}}$$

And the expression for the orbital period is:

$$T = 2\pi \sqrt{\frac{r^3}{GM}}$$

**Q.1b** A satellite is orbiting Earth in a uniform circular orbit at a height of 630 km from the surface of Earth. Assuming the radius of Earth and its mass to be 6370 km and  $5.98 \times 10^{24}$  kg, respectively, determine the velocity of the satellite. (Take gravitational constant  $G = 6.67 \times 10^{-11} \text{ Nm}^2/\text{kg}^2$ ).

**Answer:**

To calculate the velocity of a satellite orbiting Earth in a uniform circular orbit, we use the formula derived from Newton's law of gravitation and centripetal force:

$$v = \sqrt{\frac{GM}{r}}$$

**Given Data:**

- Gravitational constant,  $G = 6.67 \times 10^{-11} \text{ Nm}^2/\text{kg}^2$
- Mass of Earth,  $M = 5.98 \times 10^{24} \text{ kg}$
- Radius of Earth,  $R_E = 6370 \text{ km} = 6.37 \times 10^6 \text{ m}$
- Height of the satellite above Earth,  $h = 630 \text{ km} = 6.3 \times 10^5 \text{ m}$

The total distance  $r$  from the center of Earth to the satellite is:

$$r = R_E + h = 6.37 \times 10^6 \text{ m} + 6.3 \times 10^5 \text{ m}$$

$$r = 7.0 \times 10^6 \text{ m}$$

**Substituting into the formula:**

$$v = \sqrt{\frac{(6.67 \times 10^{-11})(5.98 \times 10^{24})}{7.0 \times 10^6}}$$

**Step-by-step calculation:**

1. Compute  $GM$ :

$$GM = (6.67 \times 10^{-11}) \times (5.98 \times 10^{24}) = 3.98666 \times 10^{14}$$

2. Divide by  $r$ :

$$\frac{GM}{r} = \frac{3.98666 \times 10^{14}}{7.0 \times 10^6} = 5.69523 \times 10^7$$

3. Take the square root:

$$v = \sqrt{5.69523 \times 10^7} = 7546.65 \text{ m/s}$$

**Final Answer:**

The velocity of the satellite is approximately:

$$v \approx 7547 \text{ m/s}$$

## Q.2

a. The apogee and perigee distances of a satellite orbiting in an elliptical orbit are 45000 km and 7000 km. Determine the following:

i. Semi-major axis of the elliptical orbit.

ii. Orbit eccentricity.

iii. Distance between the center of Earth and the center of the elliptical orbit.

Answer:

### (a) Calculation of Orbital Properties:

Given:

- Apogee distance ( $r_a$ ) = 45,000 km =  $4.5 \times 10^7$  m
- Perigee distance ( $r_p$ ) = 7,000 km =  $7 \times 10^6$  m

(i) Semi-major axis ( $a$ ):

The semi-major axis of an elliptical orbit is the average of the apogee and perigee distances:

$$a = \frac{r_a + r_p}{2}$$

Substitute the values:

$$a = \frac{4.5 \times 10^7 + 7 \times 10^6}{2}$$
$$a = \frac{5.2 \times 10^7}{2} = 2.6 \times 10^7 \text{ m} = 26,000 \text{ km}$$

(ii) Orbit eccentricity ( $e$ ):

Eccentricity is given by:

$$e = \frac{r_a - r_p}{r_a + r_p}$$

Substitute the values:

$$e = \frac{4.5 \times 10^7 - 7 \times 10^6}{4.5 \times 10^7 + 7 \times 10^6}$$
$$e = \frac{3.8 \times 10^7}{5.2 \times 10^7} = 0.7308$$

(iii) Distance between the center of Earth and the center of the elliptical orbit:

The distance between the Earth's center and the orbit center is the product of the semi-major axis and eccentricity:

$$d = a \cdot e$$

Substitute the values:

$$d = (2.6 \times 10^7) \cdot (0.7308)$$

$$d = 1.900 \times 10^7 \text{ m} = 19,000 \text{ km}$$

**b. Explain briefly any six orbital parameters required to determine a satellite orbit.**

**Answer:**

Orbital parameters are the fundamental elements that define the specific trajectory and shape of an orbit around a celestial body. For satellites and other space objects, these parameters describe the position, shape, and orientation of an orbit, allowing scientists and engineers to predict and control satellite motion. The primary orbital parameters include:

- 1. Semi-Major Axis ( $a$ ):** This is the longest radius of an elliptical orbit and determines the size of the orbit.
- 2. Eccentricity ( $e$ ):** This describes the shape of the orbit, indicating how much it deviates from a perfect circle (0 for circular orbits and values close to 1 for highly elliptical orbits).
- 3. Inclination ( $i$ ):** The tilt of the orbit relative to the equatorial plane of the primary body, measured in degrees.
- 4. Right Ascension of the Ascending Node (RAAN or  $\Omega$ ):** The angle from a reference direction (usually the vernal equinox) to the direction of the ascending node, where the orbit crosses the equatorial plane going northward.
- 5. Argument of Periapsis ( $\omega$ ):** The angle within the orbital plane between the ascending node and the orbit's point of closest approach to the primary body.
- 6. True Anomaly ( $\nu$ ):** The angle between the periapsis and the satellite's current position in its orbit, measured at the primary body.

These parameters help in determining the orbit's orientation, size, and shape, allowing precise calculations for satellite positioning and tracking.

***Advantages of Geostationary Orbit:***

A geostationary orbit (GEO) is a high Earth orbit where a satellite moves at the Earth's rotational speed, maintaining a fixed position relative to the Earth's surface at an altitude of approximately 35,786 km. Key advantages of geostationary orbits include:

- 1. Constant Position:** A geostationary satellite remains above the same point on Earth, making it ideal for continuous observation and communications with a fixed area.
- 2. Ideal for Telecommunications:** The stationary position simplifies the design of ground-based antennas, which do not need to track the satellite's movement. This makes GEO satellites suitable for TV broadcasting, internet, and telephone services.
- 3. Wide Coverage:** Due to its high altitude, a single GEO satellite can cover a large portion of the Earth's surface, particularly valuable for regions near the equator.
- 4. Weather Monitoring:** GEO satellites provide consistent imaging of the same region, essential for weather forecasting and environmental monitoring.

**5. Lower Maintenance Costs:** Geostationary satellites do not require complex ground-based tracking, reducing operational and maintenance costs for ground stations.

## Module 2

### Q.3

**a. Explain the satellite subsystems.**

**Answer:**

***Power Subsystem:***

- ❖ Provides electrical power to the satellite components.
- ❖ Includes solar panels, batteries, and power management units.

***Communication Subsystem:***

- ❖ Ensures data transmission between the satellite and ground stations.
- ❖ Consists of antennas, transponders, and modulators/demodulators.

***Attitude and Orbit Control Subsystem (AOCS):***

- ❖ Maintains the satellite's orientation and ensures it stays in its intended orbit.
- ❖ Uses sensors, gyroscopes, and thrusters.

***Thermal Control Subsystem:***

- ❖ Regulates the satellite's temperature to protect sensitive equipment.
- ❖ Includes insulation, radiators, and heaters.

***Payload Subsystem:***

- ❖ The main functional system that performs the satellite's mission (e.g., cameras, scientific instruments, or communication devices).

***Structural Subsystem:***

- ❖ Provides mechanical support and protection for all components.
- ❖ Made from lightweight, durable materials to withstand the launch and space environment.

***Telemetry, Tracking, and Command (TT&C) Subsystem:***

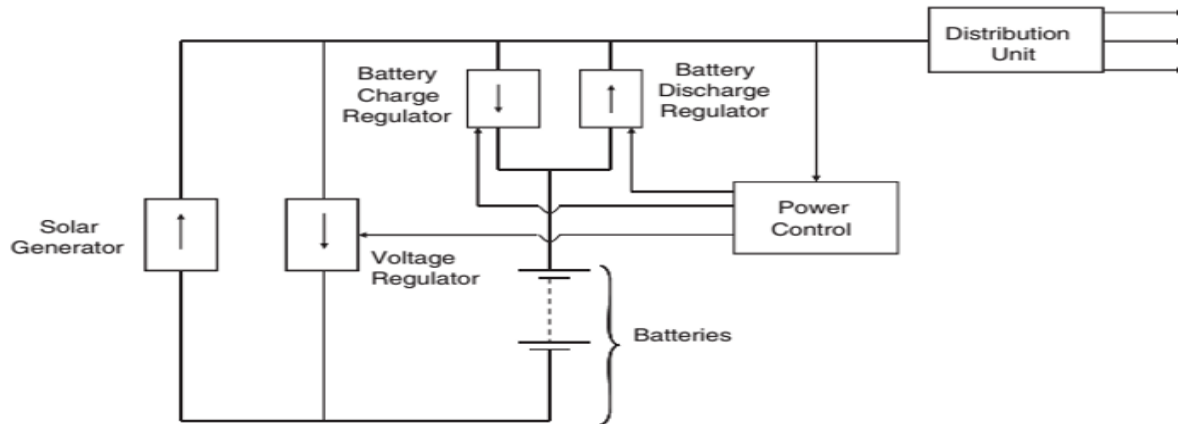
- ❖ Monitors satellite health and allows ground stations to send commands.
- ❖ Includes sensors, transceivers, and telemetry processors.

**b. Explain the solar energy-driven power supply system of a satellite.**

**Answer:**

## Solar Energy Driven Power Systems

The major components of a solar power system are the solar panels (of which the solar cell is the basic element), rechargeable batteries, battery chargers with inbuilt controllers, regulators and inverters to generate various d.c and a.c voltages required by various subsystems.



**Fig: Basic block schematic arrangement of a regulated bus power supply system**

### *Solar Energy-Driven Power Supply System of a Satellite:*

The solar energy-driven power supply system is essential for providing continuous power to the satellite in orbit. It consists of the following key components:

#### **1. Solar Panels:**

- ❖ Solar panels are made of photovoltaic (PV) cells that convert sunlight into electrical energy.
- ❖ These panels are usually deployed after the satellite reaches orbit and are oriented to maximize sunlight exposure.

#### **2. Power Conditioning Unit:**

- ❖ Converts the raw electrical energy generated by the solar panels into a regulated form suitable for the satellite's subsystems.
- ❖ It ensures a constant and stable power supply even when the sunlight intensity varies.

#### **3. Rechargeable Batteries:**

- ❖ Store excess energy generated by the solar panels during sunlight (daylight) periods.
- ❖ Provide power during eclipse periods when the satellite is in the Earth's shadow and the solar panels cannot generate electricity.

#### **4. Energy Management System:**

- ❖ Monitors and manages the distribution of power across all satellite subsystems.
- ❖ Ensures optimal charging and discharging of the batteries to prevent overcharging or deep discharging, which could damage them.

#### **5. Thermal Control for Solar Panels:**

- ❖ Protects the solar panels and batteries from extreme temperature fluctuations in space, ensuring their efficient operation.

### **Working Process:**

- ❖ During sunlight exposure, the solar panels generate power, which is used directly to operate the satellite systems and charge the batteries.
- ❖ When the satellite passes through the Earth's shadow (eclipse), the batteries take over and supply the necessary power to keep the satellite functioning.
- ❖ This system ensures that the satellite has an uninterrupted power supply for its mission throughout its operational life.

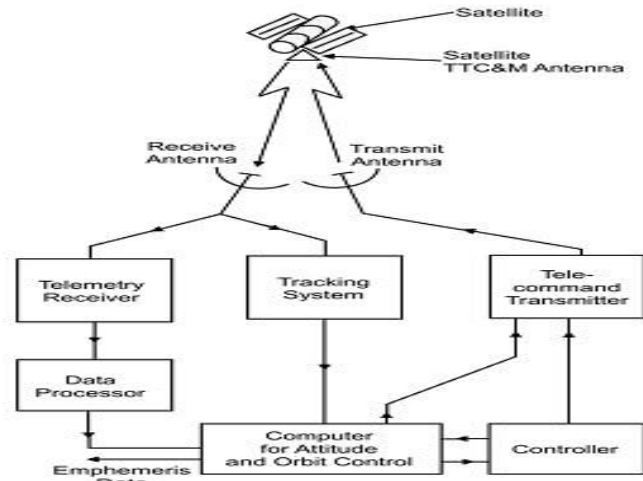
#### Q.4

a. Describe the telemetry, telecommand, and tracking control monitoring system of a communication satellite.

Answer:

#### Tracking, Telemetry and Command Subsystem

- ❖ The tracking, telemetry and command (TT&C) subsystem monitors and controls the satellite right from the lift-off stage to the end of its operational life in space.
- ❖ The tracking part of the subsystem determines the position of the spacecraft and follows its travel using angle, range and velocity information.
- ❖ The telemetry part gathers information on the health of various subsystems of the satellite. It encodes this information and then transmits the same towards the Earth control centre.



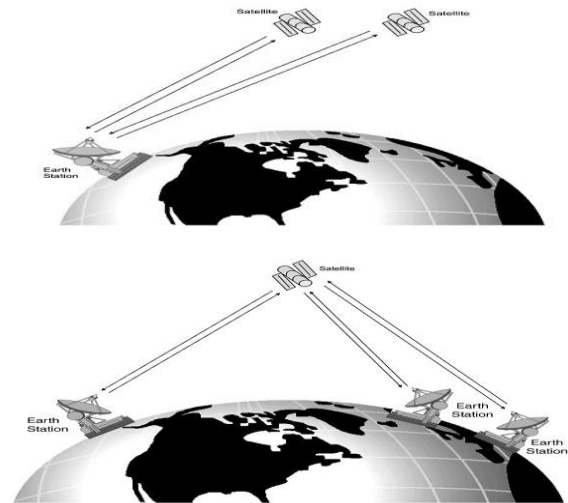
**Fig: Block schematic arrangement of the basic TT&C subsystem**

- ❖ The command element receives and executes remote control commands from the control centre on Earth to effect changes to the platform functions, configuration, position and velocity.
- ❖ Tracking is used to determine the orbital parameters of the satellite on a regular basis.
- ❖ This helps in maintaining the satellite in the desired orbit and in providing look-angle information to the Earth stations.
- ❖ During the orbital injection and positioning phase, the telemetry link is primarily used by the tracking system to establish a satellite-to-Earth control centre communications channel.
- ❖ Its primary function is to monitor the health of various subsystems on board the satellite.
- ❖ It gathers data from a variety of sensors and then transmits that data to the Earth control centre.
- ❖ With the modulation signal as digital, various signals are multiplexed using the time division multiplexing (TDM) technique.
- ❖ The bit rates involved in telemetry signals are low, it allows a smaller receiver bandwidth to be used at the Earth control centre with good signal-to-noise ratio.
- ❖ The command element is used to receive, verify and execute remote control commands from the satellite control centre.
- ❖ The functions performed by the command element include controlling certain functions during the orbital injection and positioning phase, including firing the apogee boost motor and extending solar panels, during the launch phase.
- ❖ The control commands received by the command element on the satellite are first stored on the satellite and then retransmitted back to the Earth control station via a telemetry link for verification.

b. Explain with block schematic arrangement of a generalized Earth's station.

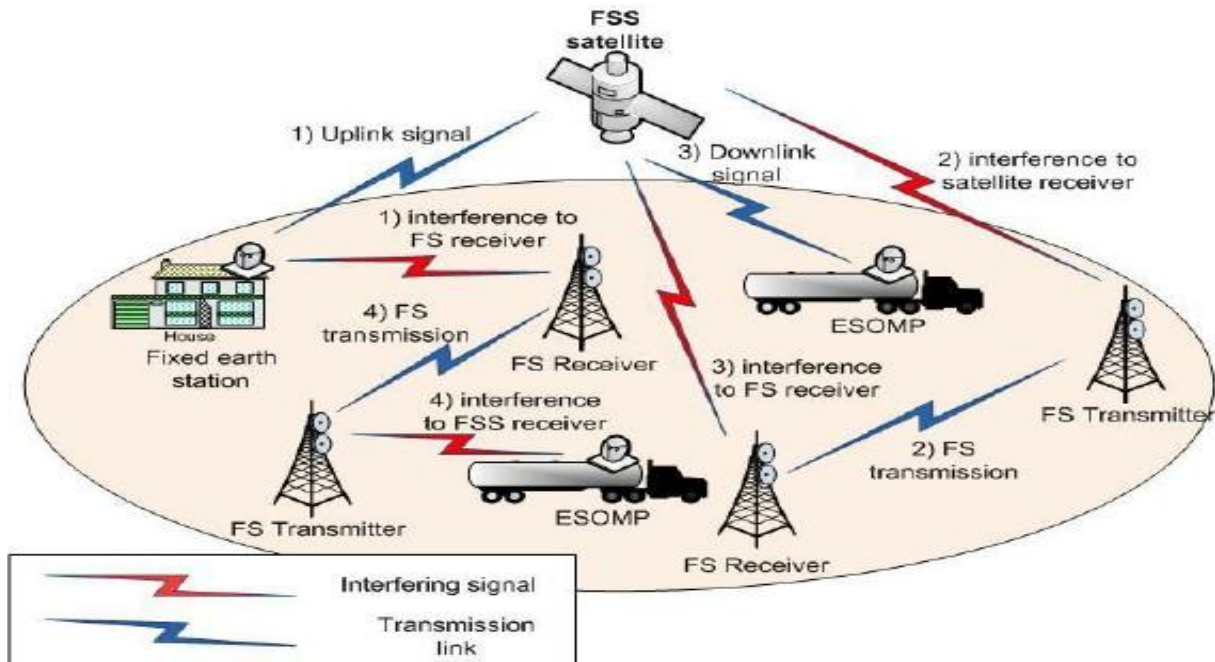
**Answer:**

- ❖ An Earth station is a terrestrial terminal station mainly located on the Earth's surface. It could even be airborne or maritime.
- ❖ Those located on the Earth's surface could either be fixed or mobile.
- ❖ The Earth station is intended for communication with one or more manned or unmanned space stations or with one or more terrestrial stations of the same type via one or more reflecting satellites or other objects in space
- ❖ Earth stations transmit and receive from satellites.
- ❖ In some special applications, the Earth stations only transmit or receive from satellites.
- ❖ Receive-only Earth station terminals are mainly of relevance in the case of broadcast transmissions.
- ❖ Transmit-only Earth station terminals are relevant to data gathering applications.

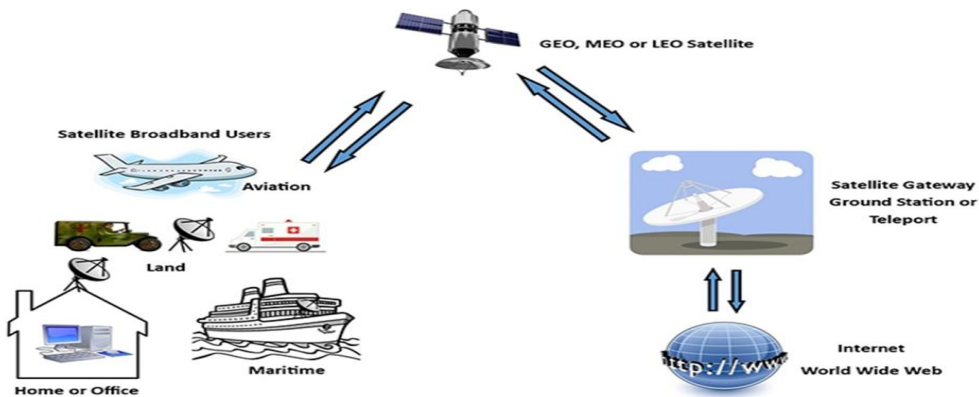


**Fig: Earth station communicating with another Earth station**

### Fixed Satellite Service (FSS) Earth Stations



### Broadcast Satellite Service (BSS) Earth Stations



### Module 3

Q.5

a. What is a transponder? Explain the various types of transponders.

Answer:

A transponder (short for transmitter-responder) is an essential electronic device in a satellite that receives signals from the Earth, amplifies them, changes their frequency, and retransmits them back to the Earth. Transponders act as communication links between the satellite and ground stations. They are crucial for satellite communication systems in transmitting TV, radio, internet, and telephone signals.

### ***Types of Transponders:***

#### **1. Bent-Pipe Transponder:**

- ❖ This type of transponder directly amplifies and retransmits the received signal without making significant changes to its format.
- ❖ Primarily used for communication satellites.
- ❖ Example: TV broadcasting and satellite phone systems.

#### **2. Regenerative Transponder:**

- ❖ This transponder processes the incoming signal, demodulates it, removes noise, and remodulates it before transmission.
- ❖ It improves the signal quality by reducing noise and distortion.
- ❖ Often used in modern communication systems like internet services via satellites.

#### **3. Transparent Transponder:**

- ❖ A subtype of bent-pipe transponders where the signal passes through without any onboard processing.
- ❖ Frequency translation occurs to prevent interference.

#### **4. Wideband Transponder:**

- ❖ Used to handle signals with a broad frequency range.
- ❖ Ideal for applications like broadband internet and high-definition TV broadcasts.

#### **5. Narrowband Transponder:**

- ❖ Designed to handle a limited frequency range for specific applications.
- ❖ Used in systems like GPS and telemetry.

#### **6. Active Transponder:**

- ❖ Contains onboard amplifiers to boost the strength of the signal before retransmission.
- ❖ Used in long-range communication satellites.

#### **7. Passive Transponder:**

- ❖ Reflects signals without amplifying them, often used in simple applications like RFID tags or ground-based transponders.

### ***Working of a Transponder:***

1. Signal Reception: The transponder's antenna receives uplink signals from the Earth station.
  2. Frequency Conversion: The signal's frequency is shifted to a different band (to avoid interference between uplink and downlink signals).
  3. Amplification: The signal is amplified to compensate for attenuation during transmission.
  4. Signal Transmission: The processed signal is retransmitted to the Earth's receiving stations.
- Transponders are critical for ensuring seamless and reliable communication in satellite-based systems.

### **b. List the advantages and disadvantages of satellites with respect to terrestrial networks.**

#### **Answer:**

#### ***Advantages of Satellites with Respect to Terrestrial Networks:***

##### **1. Wide Coverage Area:**

- ❖ Satellites can cover vast geographical areas, including remote regions, oceans, and rural areas where terrestrial networks are unavailable.

##### **2. Global Connectivity:**

- ❖ Provides seamless global communication, enabling international broadcasting and data transmission.

##### **3. Cost-Effective for Large Areas:**

- ❖ For covering large and sparsely populated regions, satellites are more economical than building extensive terrestrial infrastructure.

**4. Reliable Communication:**

❖ Satellite networks are less affected by natural disasters like earthquakes and floods, which can disrupt terrestrial networks.

**5. Broadcast Capability:**

❖ Satellites are ideal for broadcasting services like TV and radio to a large audience simultaneously.

**6. Quick Deployment:**

❖ Satellites can be launched and deployed quickly to provide connectivity, especially in emergencies or disaster recovery.

**7. Versatility:**

❖ Supports various applications such as navigation (GPS), weather monitoring, military surveillance, and communication.

**Disadvantages of Satellites with Respect to Terrestrial Networks:**

**1. High Initial Cost:**

❖ Satellite design, launch, and maintenance involve significant upfront investments.

**2. Signal Delay (Latency):**

❖ Communication via satellites, especially geostationary ones, experiences higher latency compared to terrestrial networks.

**3. Limited Bandwidth:**

❖ Satellites have finite bandwidth, which can result in congestion during high-demand periods.

**4. Weather Dependency:**

❖ Satellite signals can be affected by atmospheric conditions like rain, snow, or storms, leading to signal degradation (rain fade).

**5. Complexity in Maintenance:**

❖ Satellites in space cannot be physically repaired or upgraded easily once launched.

**6. Risk of Collision and Space Debris:**

❖ Satellites face the risk of collision with space debris, potentially leading to operational failures.

**7. Power Limitations:**

❖ Satellites have limited onboard power resources, affecting their operational lifespan and functionality over time.

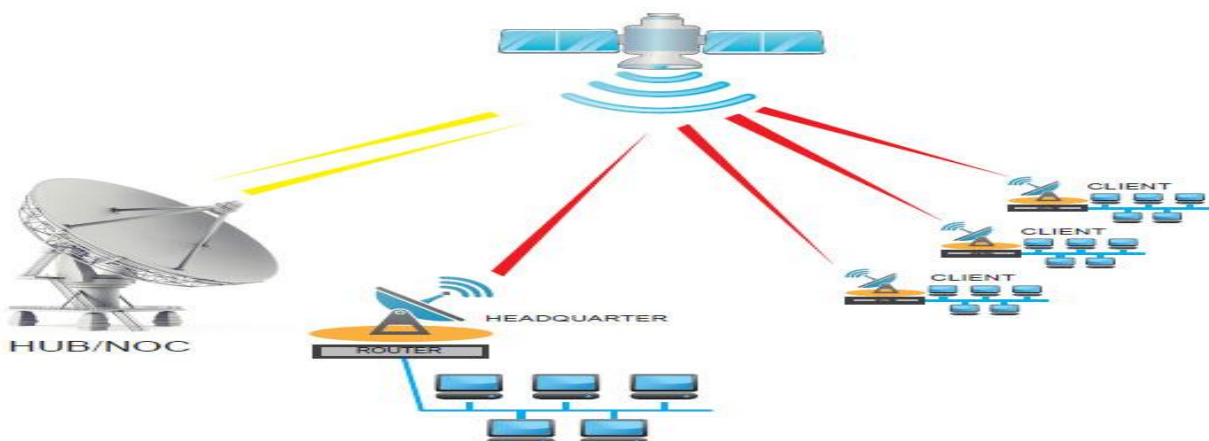
**8. Security Concerns:**

❖ Satellite communications are susceptible to interception, jamming, or hacking, raising security challenges.

**Q.6**

**a. Explain with a neat diagram the satellite point-to-point telephonic network.**

**Answer:**



A satellite point-to-point telephonic network uses satellites to establish communication links between two ground stations that are geographically distant. The satellite acts as a repeater in space, receiving signals from one ground station, amplifying them, and transmitting them to the other ground station.

**Key Steps in the Network:**

**1. Uplink Transmission:**

❖ The telephonic signal is transmitted from the first ground station (Station A) to the satellite using uplink frequencies.

**2. Satellite Processing:**

❖ The satellite receives the signal, amplifies it, and may convert it to a different frequency (to avoid interference) before retransmitting it.

**3. Downlink Transmission:**

❖ The satellite transmits the processed signal back to the second ground station (Station B) using downlink frequencies.

**4. Point-to-Point Communication:**

❖ The second ground station decodes the signal and establishes the telephonic communication.

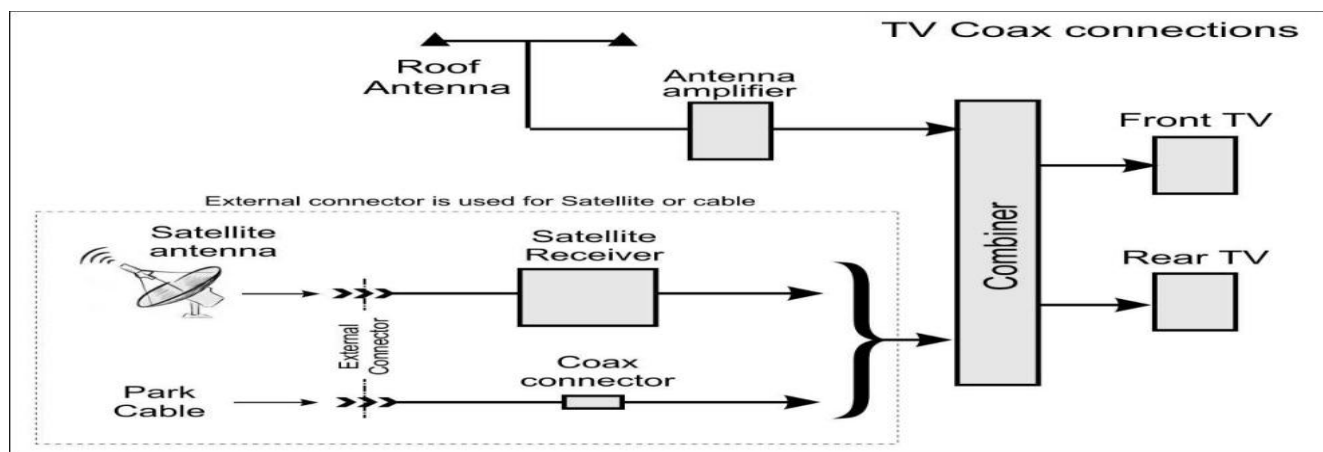
**b. Explain with a neat diagram the satellite cable TV.**

**Answer:**

Satellite cable TV refers to the delivery of television programming using signals transmitted via satellites to satellite dishes installed at subscribers' locations. The process involves the following steps:

1. **Transmission:** Television channels are uplinked from a broadcasting station to a satellite orbiting the Earth. The transmission involves the encoding and modulating of the TV signal onto a microwave frequency, which is transmitted by the satellite.
2. **Reception:** The satellite signal is received by a parabolic satellite dish installed at the user's location. The dish acts as a receiver, collecting the signals from the satellite.
3. **Conversion:** The satellite dish sends the received signals to a Low Noise Block (LNB) converter mounted on the dish. The LNB converts the high-frequency satellite signal to a lower frequency that can be used by the receiver inside the home.
4. **Signal Transmission to TV:** The converted signal is sent through a cable to the set-top box or decoder, which then decodes the signal into standard TV channels. The decoded signal is sent to the television for viewing.

In summary, satellite cable TV involves broadcasting television signals from a ground station to a satellite, which then relays the signals to a satellite dish at the subscriber's location. The signals are then converted, decoded, and displayed on the TV screen.



## Module 4

### Q.7

a. Explain the mode theory as applied to circular wavelength (waveguides) in optical fibers.

#### Answer:

The mode theory in optical fibers, specifically as applied to circular waveguides, is an important concept for understanding how light propagates through an optical fiber. Optical fibers are designed to guide light along a specific path using total internal reflection. This is achieved by utilizing the refractive index difference between the core and the cladding of the fiber. Mode theory helps to explain the behaviour of light as it propagates through the fiber core, and it classifies different patterns of light propagation known as "modes."

#### **1. Waveguide Structure:**

An optical fiber consists of:

**Core:** The central part of the fiber where light is transmitted, typically made of a material with a higher refractive index (e.g., silica).

**Cladding:** Surrounds the core and has a lower refractive index, ensuring that light stays confined within the core by total internal reflection.

#### **2. Basic Mode Theory:**

The light propagating through an optical fiber can be represented as electromagnetic waves. The core of the fiber confines the waveguide modes, which are the discrete patterns of light that can exist in the core. The modes of the waveguide are determined by the core diameter, the wavelength of the light, and the refractive index difference between the core and cladding.

#### **3. Types of Modes in Optical Fibers:**

There are two broad categories of modes:

**Guided Modes:** These are the discrete modes of propagation where the electromagnetic waves are confined within the core and guided through the fiber.

**Radiation Modes:** These are not confined to the core and radiate outward, not contributing to the propagation of light through the fiber.

The guided modes can be classified into:

**Fundamental Mode:** This is the lowest-order mode, with the simplest field distribution.

**Higher-Order Modes:** These are modes with more complex field distributions that occur at higher frequencies.

#### **4. Mode Theory Applied to Circular Waveguides:**

In the case of a circular optical fiber, the mode theory is applied by solving Maxwell's equations in cylindrical coordinates. This leads to the quantization of the modes, where the light is confined to certain discrete paths determined by the boundary conditions imposed by the fiber's geometry and the refractive index contrast.

**Cylindrical Coordinates:** Since the optical fiber is circular in cross-section, the solution to Maxwell's equations is simplified by assuming cylindrical symmetry, where the radial distance  $r$ , angular position  $\theta$ , and axial position  $z$  are the key coordinates.

**Transverse Electric (TE) and Transverse Magnetic (TM) Modes:** In cylindrical waveguides, the modes are classified as TE or TM:

**TE Modes:** In these modes, the electric field has no component in the direction of propagation (the  $z$ -direction), and only the magnetic field has a component in the propagation direction.

**TM Modes:** In these modes, the magnetic field has no component in the direction of propagation, and only the electric field has a component in the propagation direction.

### **5. Mode Propagation:**

When light enters the fiber, it excites a particular mode or combination of modes. The propagation of these modes is governed by the principle of total internal reflection, which ensures that the light is confined within the core. The different modes have different propagation constants, which result in different velocities of light propagation, leading to modal dispersion in multi-mode fibers.

### **6. Mode Field Distribution:**

LP Modes (Linearly Polarized Modes): In most practical optical fibers, the modes are described in terms of LP (Linearly Polarized) modes, which combine both TE and TM modes into a single framework. The electric field distribution of each mode is described by specific mathematical functions, with the fundamental mode having the simplest, most symmetric field distribution, and higher-order modes having more complex field patterns.

## **b. Describe the operational difference between single-mode and multimode fibers in terms of bandwidth and attenuation.**

### **Answer:**

The operational differences between single-mode and multi-mode fibers primarily lie in their bandwidth and attenuation characteristics, which significantly impact their performance in optical communication systems. These differences stem from the fibre's structure, core diameter, and the propagation modes of light within the fiber.

### **1. Single-Mode Fiber (SMF):**

#### **Core Diameter:**

The core of a single-mode fiber is much smaller, typically around 8 to 10 microns in diameter.

Mode of Propagation: Single-mode fibers support only a single mode of light propagation, which travels straight down the center of the core. The light is guided through the fiber by total internal reflection without significant reflection or scattering.

#### **Bandwidth:**

Single-mode fibers have higher bandwidth compared to multi-mode fibers. This is because they only support one mode of light propagation (fundamental mode), eliminating mode dispersion (the spreading of light pulses).

As a result, single-mode fibers can transmit data over longer distances with high data rates (typically several gigabits per second or higher) without significant signal distortion due to modal dispersion.

Effective Bandwidth: Single-mode fibers are better suited for high-speed, long-distance communication, such as intercontinental communication or backbone networks.

#### **Attenuation:**

Single-mode fibers generally have lower attenuation compared to multi-mode fibers. Attenuation is the loss of signal strength as light propagates through the fiber, and it is lower in single-mode fibers because the smaller core results in less scattering and fewer losses.

Typical Attenuation: Around 0.2 dB/km for a well-constructed single-mode fiber at 1310 nm wavelength.

This low attenuation allows signals to travel over long distances without needing frequent amplification.

### **2. Multi-Mode Fiber (MMF):**

**Core Diameter:** Multi-mode fibers have a larger core diameter, typically between 50 to 100 microns.

**Mode of Propagation:** Multi-mode fibers support the propagation of multiple modes of light, meaning light rays take different paths through the fiber core. This leads to modal dispersion, where light pulses spread out as they travel down the fiber due to different travel times for each mode.

**Bandwidth:**

Multi-mode fibers have lower bandwidth compared to single-mode fibers because the different light paths (modes) result in modal dispersion. The spread-out light pulses lead to signal distortion, limiting the data rate over longer distances.

Effective Bandwidth: Multi-mode fibers are suitable for shorter-distance, lower-speed applications, such as within data centers or local area networks (LANs), where the distances are shorter, and the impact of modal dispersion is less pronounced.

Higher Bandwidth is achievable at shorter distances, but it decreases rapidly as the transmission distance increases.

**Attenuation:**

Multi-mode fibers generally experience higher attenuation compared to single-mode fibers. This is due to the larger core size, which results in greater scattering and more loss of light energy.

Typical Attenuation: Around 0.5 dB/km to 3 dB/km, depending on the type of multi-mode fiber and wavelength (e.g., 850 nm, 1300 nm).

The increased attenuation reduces the fibre's effective transmission distance, requiring more frequent signal amplification or regeneration over long distances.

**Q.8**

**a. What is modal delay, and how does it contribute to modal dispersion in multimode fibers?**

**Answer:**

Modal delay refers to the time it takes for light signals (or modes) to travel through the core of a multimode fiber from one end to the other. In multimode fibers, different light rays (or modes) take different paths through the core, depending on their angles of incidence at the fiber core-cladding interface. Since these paths vary in length, the time it takes for each mode to travel from the light source to the detector also varies. This difference in travel times is called modal delay.

**Modal Dispersion**

Modal dispersion is a result of modal delay in multimode fibers. It refers to the spreading of light pulses over time as they propagate through the fiber, due to the different travel times of the various modes. This spreading can cause distortion of the signal, as the light pulses get stretched out and overlap with other pulses, leading to errors in the received signal. Modal dispersion is one of the primary limitations in multimode fiber communication.

**How Modal Delay Leads to Modal Dispersion:**

In a multimode fiber, light can follow multiple paths or modes:

**Axial mode (central ray):** This ray travels straight through the core, with the shortest possible path.

**Higher-order modes:** These rays take different angles of incidence and follow longer, more curved paths within the core.

As these different modes travel along the fiber, they will reach the other end at different times due to the varying lengths of the paths they take. This time difference is called modal delay. Here's how it contributes to modal dispersion:

1. **Different Path Lengths:** Light rays traveling through different modes follow different paths. For example:  
The central mode (straight path) has the shortest travel time.  
The higher-order modes take longer, more indirect paths, which result in longer travel times.
2. **Pulse Broadening:** Since the light rays reach the receiver at different times, the transmitted pulse broadens as it propagates down the fiber. The pulse spreads out over time due to the different modal delays, causing the light pulses to overlap and distort.

3. **Increased Dispersion at Longer Distances:** As the distance increases, the difference in travel times between modes becomes more pronounced. This results in greater pulse broadening and more severe modal dispersion, reducing the effective bandwidth and transmission distance of multimode fibers.

#### ***Visualizing Modal Delay and Modal Dispersion:***

If you consider a light pulse launched into the fiber at a given time, different modes will arrive at the receiver at different times, causing the pulse to stretch out over time. In an ideal system without modal dispersion, the pulse would remain tightly packed and distinct. However, due to modal delay, the pulse spreads out, which can lead to overlapping pulses, making it harder to accurately decode the signal.

Summary of Modal Delay's Contribution to Modal Dispersion:

- ❖ **Modal Delay:** The time difference between when different modes of light reach the receiver due to varying path lengths.
- ❖ **Modal Dispersion:** The result of modal delay, where light pulses are broadened over time as they propagate, leading to signal distortion.
- ❖ **Impact:** The greater the modal delay (and hence the path length difference), the more significant the modal dispersion, which reduces the fibre's bandwidth-distance product and limits its effectiveness for high-speed, long-distance communications.

#### **b. Define material dispersion and explain how it arises in optical fibers.**

##### **Answer:**

Material dispersion refers to the phenomenon where different wavelengths of light travel at different speeds through the core material of an optical fiber. This results in the spreading or broadening of light pulses over time as they propagate through the fiber. Material dispersion is caused by the variation in the refractive index of the fiber material with respect to the wavelength of light. This type of dispersion occurs due to the intrinsic properties of the fiber material and is independent of the fiber's structure (unlike modal dispersion, which is related to the fiber's geometry).

#### ***How Material Dispersion Arises in Optical Fibers***

The core of an optical fiber is typically made of silica ( $\text{SiO}_2$ ) or similar materials, which have a wavelength-dependent refractive index. This means that the speed at which light propagates through the fiber depends on the wavelength of the light. Different wavelengths of light travel at different speeds because the refractive index is not constant across all wavelengths.

- ❖ Shorter wavelengths (blue light) generally experience higher refractive indices and travel more slowly.
  - ❖ Longer wavelengths (red light) generally experience lower refractive indices and travel faster.
- This difference in propagation speeds leads to the spreading out of light pulses over distance, especially when broadband signals containing multiple wavelengths are used.

#### ***Key Points on Material Dispersion:***

1. **Wavelength Dependence of Refractive Index:** The refractive index of the fiber's core material decreases as the wavelength of light increases. This causes the different components of a pulse (corresponding to different wavelengths) to arrive at the receiver at different times.
2. **Pulse Broadening:** As a result of the different propagation speeds of various wavelengths, pulses become broader over distance, leading to temporal spreading or pulse broadening. This broadening of pulses reduces the ability of the fiber to transmit high-speed data, as the pulses can overlap and interfere with each other.
3. **Chromatic Dispersion:** Material dispersion is a key component of chromatic dispersion, which is the total dispersion caused by the different speeds of various wavelengths. Chromatic dispersion is a combination of material dispersion (due to the wavelength dependence of the refractive index) and waveguide dispersion (due to the structure of the fiber itself).

**Example:**

**In a typical single-mode fiber:**

- Light with a shorter wavelength (e.g., 1310 nm) travels slower through the fiber core because the refractive index is higher at this wavelength.
- Light with a longer wavelength (e.g., 1550 nm) travels faster, as the refractive index at this wavelength is lower.
- As a result, light pulses at these different wavelengths will spread out in time, especially when the signal consists of multiple wavelengths.

**Material Dispersion in Fiber Communication:**

- Effect on Data Transmission: Material dispersion is more pronounced in longer wavelength fibers (such as 1550 nm) because the difference in refractive index is more significant. This can limit the fiber's bandwidth, especially over long distances, as the pulse broadening can cause signal overlap and distortion.
- Reduction of Material Dispersion: To mitigate the effects of material dispersion, fibers are often designed to minimize the differences in refractive index across the transmission wavelengths. This is particularly important in long-distance, high-speed communication systems. Advanced fiber designs such as dispersion-shifted fibers and dispersion-compensated fibers can help reduce material dispersion and maintain signal integrity.

## Module 5

### **Q.9**

**a. Explain the principle operation of LEDs.**

**Answer:**

A Light Emitting Diode (LED) is a semiconductor device that emits light when an electric current passes through it. The principle of operation of an LED is based on the process of electroluminescence, where the material emits light in response to the energy provided by an electric current. LEDs are widely used in applications such as displays, indicators, and general lighting due to their energy efficiency, long lifespan, and small size.

**Key Concepts in LED Operation:**

**1. Semiconductor Material:**

- ❖ An LED is made from a semiconductor material, typically a combination of gallium-based compounds (like GaAs, GaN, or GaP), which have a band gap that is suitable for light emission.
- ❖ The specific semiconductor material determines the wavelength (color) of the emitted light. For example, GaAs typically emits infrared light, while GaN emits blue or ultraviolet light.

**2. P-N Junction:**

- ❖ An LED consists of a P-N junction: the P-type material (positive side) and the N-type material (negative side). The P-type material has an excess of holes (positive charge carriers), while the N-type material has an excess of electrons (negative charge carriers).
- ❖ The P-N junction is where the two types of semiconductor materials meet, and it is crucial for the LED's operation.

**3. Forward Bias:**

- ❖ When a forward voltage is applied across the LED (positive voltage on the P-type and negative on the N-type), the electrons from the N-type side and the holes from the P-type side are pushed toward the junction.
- ❖ As the electrons cross the junction into the P-type region, they recombine with holes. This recombination releases energy in the form of photons (light).

**4. Electroluminescence:**

- ❖ The energy released when an electron recombines with a hole is emitted as light. The wavelength (color) of this light depends on the energy gap (band gap) between the conduction band (where electrons are free to move) and the valence band (where electrons are bound to atoms).

- ❖ The greater the energy difference between these bands, the shorter the wavelength (and thus higher frequency) of the emitted light. For example, larger band gaps produce blue or ultraviolet light, while smaller gaps produce red or infrared light.

#### 5. **Light Emission:**

- ❖ The emitted photons exit the LED through the transparent window or lens that is typically made of a material like glass or plastic. The direction of emission can be controlled by the packaging of the LED, which typically includes reflective materials to focus or direct the light.

#### **Summary of the LED Working Principle:**

1. **Current Injection:** When current flows through the LED, electrons from the N-type material and holes from the P-type material meet at the P-N junction.
2. **Recombination:** Electrons recombine with holes at the junction, releasing energy in the form of photons (light).
3. **Light Emission:** The emitted photons are released as visible light, with the color determined by the energy band gap of the semiconductor material used in the LED.

#### **Key Characteristics:**

- ❖ **Efficiency:** LEDs are highly efficient because most of the energy is converted into light, with less energy wasted as heat compared to traditional light sources like incandescent bulbs.
- ❖ **Color Range:** LEDs can emit light across a wide spectrum, from infrared to ultraviolet, depending on the semiconductor material used.
- ❖ **Low Power Consumption:** LEDs consume much less power compared to other light sources, making them energy-efficient.
- ❖ **Longevity:** LEDs have a long operational lifespan, often lasting tens of thousands of hours.

#### **Advantages of LEDs:**

- ❖ **Energy Efficient:** They convert more electrical energy into light and produce less heat compared to incandescent lamps.
- ❖ **Compact and Durable:** LEDs are small in size and highly durable, resistant to shock and vibration.
- ❖ **Instant On/Off:** Unlike some other light sources (like fluorescent lamps), LEDs light up instantly with no warm-up time.
- ❖ **Environmentally Friendly:** LEDs do not contain harmful substances like mercury, making them more environmentally friendly.

#### **Applications:**

- **Display Technology:** Used in TV screens, computer monitors, and digital signage.
- **Indicators and Signalling:** Widely used in status indicators, traffic lights, and automotive lighting.
- **General Lighting:** Used in streetlights, interior lighting, and energy-efficient home lighting.

### **b. Discuss the characteristics of optical detectors.**

#### **Answer:**

#### **Wavelength Sensitivity:**

- ❖ Optical detectors are sensitive to specific wavelengths of light, often corresponding to particular regions of the electromagnetic spectrum, such as UV, visible, or infrared light.
- ❖ The spectral response of a detector determines the range of wavelengths it can effectively detect. For instance, photodiodes and phototransistors are sensitive to visible and near-infrared light, while photomultiplier tubes (PMTs) can be used for detecting ultraviolet light.

### ***Quantum Efficiency:***

- ❖ Quantum efficiency (QE) refers to the detector's ability to convert incoming photons into an electrical signal. It is defined as the ratio of the number of charge carriers generated by the detector to the number of incident photons.
- ❖ A higher QE indicates that the detector is more efficient at converting light into an electrical signal, which is crucial for low-light applications or when high sensitivity is required.

### ***Responsivity:***

- ❖ Responsivity is the measure of the output signal (current or voltage) per unit of incident optical power. It is typically expressed in units such as A/W (amperes per watt) or V/W (volts per watt).
- ❖ Responsivity is crucial in determining the efficiency of a detector in converting optical power into an electrical signal. For example, photodiodes have a high responsivity at certain wavelengths, making them suitable for optical communication systems.

### ***Dark Current:***

- ❖ Dark current is the small current that flows through the detector even in the absence of incident light. It results from thermally generated carriers and can contribute to noise in the system.
- ❖ For low-light detection or precision measurements, low dark current is desirable to avoid signal distortion. Dark current can be minimized by operating detectors at low temperatures or using specialized materials.

### ***Noise Characteristics:***

- ❖ Noise in optical detectors can arise from various sources, such as dark current, thermal noise, and shot noise. The noise level affects the signal-to-noise ratio (SNR) of the detected signal.
- ❖ A low noise equivalent power (NEP) means that the detector can detect weak optical signals without significant noise interference, which is particularly important in applications like scientific measurements, astronomy, or telecommunications.

### ***Speed of Response (Bandwidth):***

- ❖ The response time or bandwidth of an optical detector refers to how quickly it can respond to changes in the incident light intensity. The time taken for a detector to reach its maximum output after the light is applied is an important factor in high-speed applications.
- ❖ Detectors like photodiodes and phototransistors generally have high response speeds, making them suitable for fast optical communications, data transmission, and signal processing.

### ***Linear Range:***

- ❖ The linear range of an optical detector is the range of light intensities over which the output signal is directly proportional to the incident optical power.
- ❖ Detectors with a large linear range are capable of detecting both low and high light intensities without saturation, making them versatile for different light levels. Saturation occurs when the detector output no longer increases with increasing light intensity.

### ***Dynamic Range:***

- ❖ The dynamic range is the ratio between the highest and lowest optical power levels the detector can effectively measure. A high dynamic range is essential in applications where both weak and strong light signals are present simultaneously, such as in imaging systems or optical communication.

### ***Temperature Sensitivity:***

- ❖ Optical detectors may exhibit changes in their characteristics with varying temperature. For instance, temperature changes can affect the dark current and quantum efficiency, influencing the detector's performance.
- ❖ For precise measurements, detectors may need to be temperature-compensated or cooled (e.g., using thermoelectric cooling) to maintain stable performance in varying environmental conditions.

### ***Angular Sensitivity:***

- ❖ Angular sensitivity refers to the detector's ability to detect light incident at various angles relative to the detector's surface. Some detectors have a wide angular response (i.e., they can detect light from many directions), while others are more directional.
- ❖ Photodiodes and photomultiplier tubes (PMTs), for example, have specific angular response characteristics, which can affect their use in certain optical systems.

### ***Linearity of Response:***

- ❖ The linearity of response refers to how closely the output signal follows the input light intensity across the operating range of the detector. A linear response ensures that the output signal is a consistent and accurate representation of the incident light.

#### Form Factor and Packaging:

- ❖ The physical size and shape of the optical detector depend on its intended application. Some detectors are small and compact for integration into handheld devices, while others are larger for more industrial or scientific applications.
- ❖ The packaging can also influence other characteristics like optical coupling and thermal management.

## **Q.10**

### **a. Explain the principle operation of WDM standards.**

#### **Answer:**

Wavelength Division Multiplexing (WDM) is a technology used in optical fiber communication that enables the transmission of multiple signals over a single optical fiber by utilizing different wavelengths (or channels) of light. Each wavelength carries a separate data stream, and the combined signals are transmitted simultaneously through the same fiber. This effectively increases the capacity of the optical fiber, allowing for more efficient use of bandwidth.

WDM is primarily used to enhance the data transmission capacity of optical networks, such as in long-distance telecommunication systems, metropolitan area networks (MANs), and fiber-to-the-home (FTTH) services.

### ***Key Concepts in WDM***

#### **1. Wavelength:**

- ❖ In optical fiber communication, light is transmitted at specific wavelengths in the infrared spectrum, typically between 1260 nm and 1675 nm. These wavelengths are used because they lie within the low-loss window of silica optical fibers, where attenuation and dispersion are minimal.
- ❖ Different wavelengths are used to encode different data streams.

#### **2. Multiplexing and Demultiplexing:**

- ❖ Multiplexing refers to the process of combining multiple data streams onto a single optical fiber by assigning each data stream a specific wavelength.
- ❖ Demultiplexing is the reverse process, where the combined signals are separated into their original channels at the receiver.

### ***Types of WDM***

There are two main types of WDM: Coarse Wavelength Division Multiplexing (CWDM) and Dense Wavelength Division Multiplexing (DWDM). The difference between these two standards is mainly in the spacing between channels and the number of channels supported.

#### **1. Coarse Wavelength Division Multiplexing (CWDM)**

- ❖ Channel Spacing: CWDM uses wider spacing between channels (typically 20 nm), which means fewer channels can be accommodated in the available bandwidth.

- ❖ **Wavelength Range:** CWDM typically operates in the wavelength range of 1264.5 nm to 1337.5 nm, covering around 18 channels.
- ❖ **Applications:** CWDM is commonly used in access networks or short-distance communications where the data rates are lower, and fewer channels are needed.
- ❖ **Transmission Distance:** CWDM can cover distances up to 80 km without requiring optical amplifiers due to its lower transmission power requirements.

## ***2. Dense Wavelength Division Multiplexing (DWDM)***

- ❖ **Channel Spacing:** DWDM uses much narrower channel spacing (typically 0.8 nm to 1.6 nm), allowing for more channels to be placed in the same spectral range. This results in high channel density and significantly increased capacity.
- ❖ **Wavelength Range:** DWDM typically operates in the wavelength range of 1525 nm to 1565 nm (the C-band), and it can accommodate many more channels, often ranging from 40 to 160 channels (with even higher numbers in advanced systems).
- ❖ **Applications:** DWDM is used in long-distance communication and high-capacity backbone networks, where very high data rates (up to 400 Gbps per channel or more) are required.
- ❖ **Transmission Distance:** DWDM can support transmission distances of up to 1000 km or more with the use of optical amplifiers (such as erbium-doped fiber amplifiers, or EDFAs).

### ***Working Principle of WDM***

1. **Multiplexing:**
  - ❖ In the transmitter, each individual data stream is modulated onto a specific wavelength (carrier) using techniques such as laser diodes or external modulators.
  - ❖ These individual modulated signals are then combined using a multiplexer (MUX), which combines the multiple wavelengths into one signal. The MUX allows different optical signals to travel together on the same fiber, each at a distinct wavelength.
2. **Transmission:**
  - ❖ The combined signal travels through the optical fiber, and due to the nature of fiber optics, the signals do not interfere with each other because each signal operates at a different wavelength.
  - ❖ This allows multiple data streams to share the same fiber, vastly increasing the fiber's data transmission capacity.
3. **Demultiplexing:**
  - ❖ At the receiver end, a demultiplexer (DEMUX) separates the combined signal back into its individual wavelengths.
  - ❖ Each wavelength is then directed to its respective detector, such as a photodiode, where the data is decoded and processed.

## **b. Explain the isolators and circulators.**

### **Answer:**

Optical isolators and circulators are essential components in optical communication systems, used to control the direction of light propagation and protect sensitive equipment. They are passive devices that utilize the properties of polarized light to direct and isolate signals in a fiber-optic network.

### ***1. Optical Isolators***

#### ***Principle of Operation***

An optical isolator is a two-port, non-reciprocal device that allows light to pass in one direction while blocking it in the opposite direction. It is used to prevent back-reflected light from returning to sensitive components like lasers or amplifiers, which can cause instability or damage to these devices.

- ❖ **Non-Reciprocal Nature:** This property means the transmission of light is directional. The device will allow light to pass through in one direction but block it in the opposite direction, ensuring that signals are unidirectional.
- ❖ **Faraday Effect:** The working principle of an isolator relies on the Faraday effect, a phenomenon where the polarization of light is rotated when it passes through a material under the influence of a magnetic field. By using materials that exhibit the Faraday effect (typically yttrium iron garnet (YIG)), isolators can control the light's polarization, ensuring it is blocked in the reverse direction.

#### ***Working of an Isolator***

- ❖ **Polarizer:** The incoming light first passes through a polarizer, which sets the light's polarization direction.
- ❖ **Faraday Rotator:** The light then passes through a Faraday rotator, a material placed in a magnetic field that rotates the polarization of the light. The amount of rotation depends on the strength of the magnetic field and the material's properties.
- ❖ **Analyzer:** Finally, an analyzer (another polarizer) ensures that the light can pass only in one direction. For light traveling in the opposite direction, the polarization rotation will align with the analyzer's axis, blocking the light.

#### ***Applications of Optical Isolators***

- ❖ **Laser Protection:** Isolators are used to protect lasers from back-reflected light, which can destabilize the laser or damage the source.
- ❖ **Optical Amplifiers:** They are used in optical amplifiers to prevent reflected signals from re-entering the amplifier, which could lead to self-oscillation or instability.
- ❖ **Fiber Optic Communication:** They ensure signal integrity by preventing reflections from disrupting signal transmission.

## ***2. Optical Circulators***

### ***Principle of Operation***

An optical circulator is a three-port, non-reciprocal device that directs light from one port to the next in a specific direction. It is often used to route signals in multi-channel optical systems and allows light to travel in a unidirectional manner, but unlike the isolator, it circulates the light through multiple ports.

- ❖ **Non-Reciprocal Nature:** Similar to isolators, circulators rely on the Faraday effect for non-reciprocal operation. The circulator routes light through a sequence of ports in a defined direction. Typically, a three-port circulator connects three devices or components, routing the signal from port 1 to port 2, port 2 to port 3, and port 3 back to port 1, ensuring light only circulates in one direction.

### ***Working of a Circulator***

- ❖ **Port Connections:** A three-port circulator connects optical components in a loop. If light enters port 1, it is transmitted to port 2, then to port 3, and finally loops back to port 1. If light enters port 2, it will be directed to port 3, and so on.
- ❖ **Faraday Rotator:** Similar to isolators, circulators use a Faraday rotator to achieve non-reciprocal behaviour. The polarization of light is rotated in the presence of a magnetic field, allowing the device to direct light in one direction while blocking it in the reverse direction.
- ❖ **Polarization Control:** The rotation of the light's polarization ensures that the light only travels in the designed direction and prevents backward propagation.

### ***Applications of Optical Circulators***

- ❖ **Optical Communication Systems:** Circulators are used to separate the transmitted and received signals on the same fiber in systems like bi-directional fiber optic communication.
- ❖ **Optical Amplifiers:** They allow the combination of forward and backward paths in an optical amplifier, enabling signal monitoring or feedback without causing interference.
- ❖ **Interferometers and Sensing:** Circulators are used in optical sensing systems, such as optical coherence tomography (OCT), for routing light to sensors and detectors in a controlled manner.
- ❖ **Fiber Optic Networks:** They are used in optical network protection systems, where they can direct light between different paths, ensuring system reliability.