

Internal Assessment Test 2- ODD SEM 2025-26

Subject: **Applied Chemistry for Smart Systems (CSE)**

Subject Code: **1BCHES102**

Q1(a). What are liquid crystals (LCs)? Discuss their classifications and mention its properties.

Liquid crystals (LCs): An ordered fluid mesophase of an organic long-chain molecules possessing both **solid-like molecular order** and **liquid-like character** is known as a liquid Crystal.

Classification

(a) Thermotropic liquid crystals: When long-chain organic solids are heated, they undergo sharp phase transitions at a particular temperature yielding liquid crystals.

Thermotropic liquid crystals are three types:

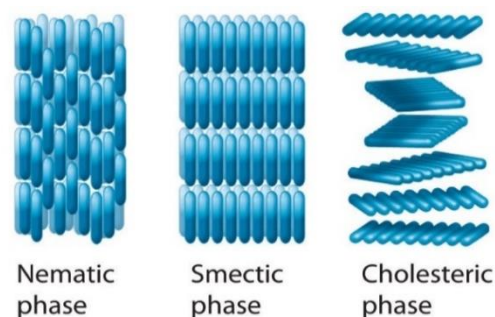

Nematic: The molecules move either sideways or up and down.

In this case, the molecules are readily aligned in the same direction in the presence of **electric and magnetic fields**. The alignment of molecules is **temperature sensitive**.

Example: p-azoxyphenetole,

Smectic: The molecules in smectic crystals are oriented parallel to each other as in the nematic phase but in layers. These layers can pass on each other because the force between the layers is weak.

Example: smectic-A

Cholesteric: The molecules in successive layers are slightly twisted or rotated with respect to the layers above and below to form a continuous helical or spiral pattern.

Example: Cholesteryl benzoate

(b) Lyotropic liquid crystals: The orientational behaviour of lyotropic crystals is a function of concentration and solvent. These molecules are amphiphilic in nature—they have both hydrophilic and hydrophobic ends in their molecules. At low concentrations, these molecules are randomly oriented but as the concentration increases, the molecules start arranging themselves.

Example: Cell membranes

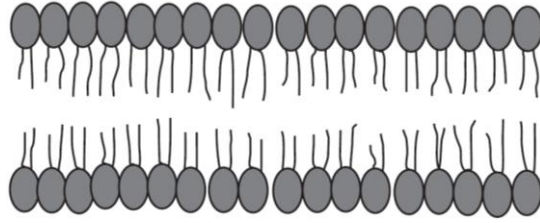

Properties of Liquid Crystals

- Liquid crystals are **anisotropic**, i.e., they exhibit different properties in different directions.
- Liquid crystals are **birefringent**, i.e., they can split light into two polarized components.
- Some liquid crystals are **optically active**, i.e., they rotate the polarization of light.
- Liquid crystals exhibit **phase transitions** with changes in temperature and pressure.
- Liquid crystals can be **sensitive to external fields**, such as electric or magnetic fields, which can affect their orientation and properties.

Q1(b). What are conducting polymers? Describe synthesis and conducting mechanism of polyaniline and mention its engineering applications.

Conducting polymer

Conducting polymers are a special class of organic polymers that can conduct electricity, unlike most conventional polymers which act as insulators.

Synthesis

Polyaniline hydrochloride is synthesized by **oxidative polymerization of aniline** in an acidic medium. Aniline is dissolved in **1 M HCl** and polymerized using **ammonium persulfate** as oxidant at low temperature, forming a **dark green polyaniline hydrochloride (emeraldine salt)** precipitate, which is filtered, washed, and dried.

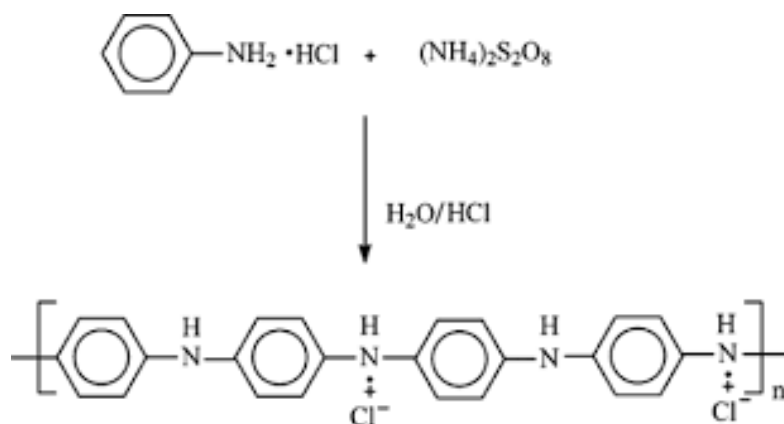

Conduction mechanism: Protonic Acid Doping

In this technique, current-carrying charged species (-ve / +ve) are created by the protonation of imine nitrogen.

- Polyaniline is partially oxidized first, using a suitable oxidizing agent, into a base form of aniline which contains alternating reduced and oxidized forms of the aniline polymer backbone.
- This base form of aniline, when treated with aqueous HCl (1M), undergoes protonation of the imine nitrogen atom.
- Protonation creates current carrying charged sites (+ve) in the polymer backbone.
- These charges are compensated by the anions (Cl^-) of the doping agent, giving the corresponding salt.
- Protonic acid doping of polyaniline results in an increase of conductivity by approximately 9–10 orders of magnitude.

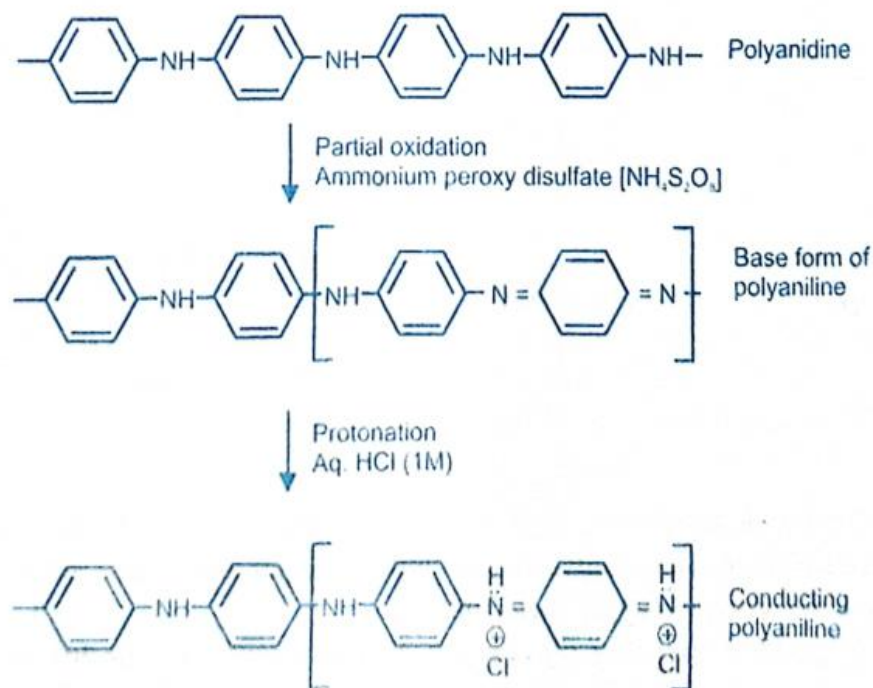

Engineering applications of conducting polymer

- Used in **gas and chemical sensors** due to conductivity changes.
- Applied as **anticorrosion coatings** on metals.
- Used in **batteries and supercapacitors** as an electrode material.
- Employed in **antistatic and EMI shielding materials** for electronics.

Q2(a). Explain the construction, working and advantages of pentacene semiconductor chip.

A **pentacene semiconductor chip** is an **organic electronic device** in which **pentacene** is used as the **active semiconducting layer**, which is deposited as a thin film between electrodes.

When a voltage is applied, holes move through the pentacene layer, allowing the device to switch electrical signals.

Construction

Pentacene-based chips are commonly used in organic field-effect transistors (OFETs). The main construction components are:

Substrate/Gate: Si (serves as gate).

Gate dielectric: 200–300 nm SiO₂

Semiconductor: Pentacene 30–50 nm

Contacts: Au (30–50 nm) source/drain

Encapsulation: Parylene-C polymer

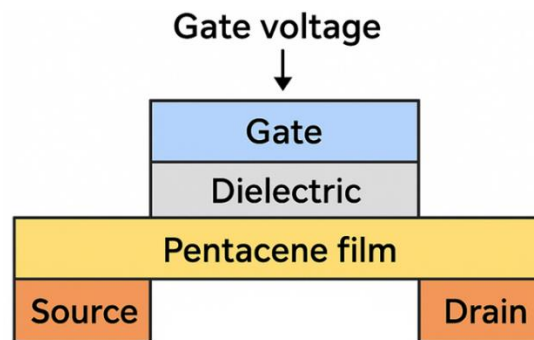

Working

- When voltage is applied to the gate electrode, an electric field is formed across the dielectric.
- This field induces charge carriers (holes) in the pentacene layer, forming a conductive channel between source and drain electrodes.
- The amount of current that flows depends on the gate voltage
- Because of its π -conjugated structure, pentacene allows efficient charge delocalization, leading to relatively high mobility for an organic material.

Advantages

- Mechanical Flexibility
- Low-Temperature and Low-Cost Fabrication
- Chemical Tunability
- High Hole Mobility
- Lightweight

Q2(b). What are organic semiconductors? Explain the types of organic semiconductors used in memory devices.

Organic semiconductors are carbon-based materials with π -conjugated systems that can conduct electricity. They are useful in electronic and memory devices.

Types of Organic Semiconductors Used in Memory Devices

(a) Small-molecule organic semiconductors

Examples: pentacene, fullerene derivatives.

Properties:

- High purity and good crystallinity
- High charge mobility
- Easy to deposit in thin films

Applications: used in **OFET-based flash memory** and **resistive memory**

(b) Polymeric organic semiconductors

Examples: P3HT, polyaniline.

Properties:

- Flexible, mechanically strong
- Moderate charge mobility
- Easy to tune conductivity through doping

Applications: used in **WORM memory**, **RRAM**, and **polymer OFET** memories,

(c) Organic-inorganic hybrid semiconductors

Examples: hybrid perovskites

Properties:

- High charge mobility
- Tunable optoelectronic properties
- Good stability with flexible

Applications: used in **RRAM** and **floating-gate memory**

Q3(a). Explain the synthesis of TiO₂-RAM nanomaterial by the sol-gel method and describe its properties and

applications.

TiO₂-RAM nanomaterial refers to titanium dioxide nanostructures used as the active layer in resistive random-access memory (RRAM) devices. TiO₂ is widely used because of its stable resistive switching behavior.

Synthesis of TiO₂ for ReRAM (Sol-Gel Method):

- A titanium precursor such as titanium isopropoxide or titanium butoxide is dissolved in alcohol.
- Controlled addition of water causes **hydrolysis**, forming a colloidal solution called a *sol*.

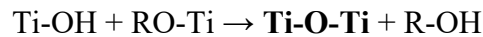
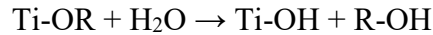

- Further condensation reactions convert the *sol* into a three-dimensional *gel* network.
- The gel is dried and calcined (300–500°C) to obtain crystalline **anatase TiO₂ nanomaterial**
- The final material can be deposited as a thin film between metal electrodes for RRAM devices.

Properties

- **Non-volatility** → Retains data without power.
- **High switching speed** (ns–μs).
- **Bipolar/Unipolar resistive switching behavior.**
- **Low power consumption** compared to Flash memory.
- **Good endurance and retention**

Applications

- **Non-volatile memory storage**
- **Neuromorphic computing**
- **Reconfigurable logic devices.**
- **Flexible and wearable electronics**
- **High-density storage devices**

Q3(b). Illustrate the construction and working principle of Organic Light Emitting Diodes (OLEDs) and discuss their applications in modern electronic displays.

Organic Light Emitting Diode (OLED) is a type of display technology that utilizes organic materials to emit light when an electric current is applied.

Construction

- **Glass or plastic substrate:** base of OLED
- **Anode:** transparent material like indium tin oxide (ITO).
- **Hole Transport Layer (HTL)**
- **Emissive Layer:** where light is produced.
- **Electron Transport Layer (ETL)**
- **Metal Cathode:** aluminium.

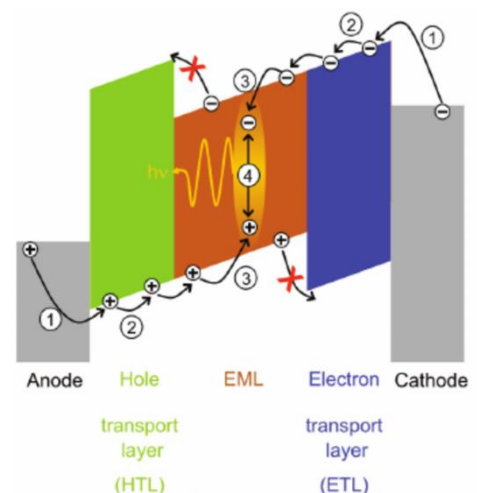

Working principle

- When a voltage is applied across the OLED device, the anode becomes positive and the cathode becomes negative. This causes **holes** to be injected from the anode and **electrons** from the cathode.
- The **holes travel through the Hole Transport Layer (HTL)**, while electrons move through the **Electron Transport Layer (ETL)**.
- When an electron and a hole recombine in the **Emissive layer (EML)**, their energy is released in the form of a **photon (light)**. The color of light depends on the type of **organic material used** (red, green, or blue).
- Since the **anode** is transparent, the light generated inside the OLED passes outward through it, producing a **visible display**.

Applications

- Smartphones, tablets, and smartwatches
- OLED televisions
- Flexible, foldable, and rollable displays
- Automotive dashboards

Q4(a). What are memory devices? Mention the difference between organic and inorganic memory devices.

Feature	Inorganic Memory Devices	Organic Memory Devices
Materials used	Silicon, metal oxides, inorganic semiconductors	Organic molecules, polymers, carbon-based materials
Charge transport	Charge moves through crystal lattices	Charge moves through π -conjugated molecular systems
Cost	High fabrication cost	Low-cost
Flexibility	Rigid, brittle	Flexible and lightweight
Performance	Very high speed and excellent stability	Moderate speed, limited long-term stability
Operating voltage	Generally low operating voltage	Moderate to high operating voltage
Applications	Computers, mobile phones, data storage chips	Flexible electronics, smart cards, wearable devices

Q4(b). Describe synthesis and properties of Nylon 6,6 and mention its advantages in 3D printing applications.

Nylon-6,6: Nylon-6,6 is an important engineering polymer known for its high strength, durability and thermal stability. It is a *synthetic polyamide* made from two monomers, each containing six carbon atoms.

Synthesis: Nylon-6,6 is prepared by condensation polymerization of hexamethylene diamine with adipic acid at high temperature and pressure. These monomers react to form a long polyamide chain with the repeating unit.

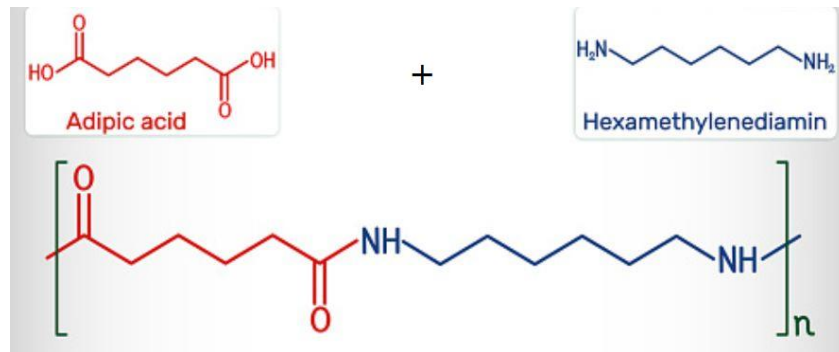

Properties:

- High strength due to strong hydrogen bonding between chains.
- Good thermal stability and can be stable up to 260°C.
- Excellent abrasion and wear resistance.
- Good chemical resistance to oils, solvents and many reagents.

Advantages in 3D Printing Applications

- Produces strong and durable printed parts suitable for functional use.
- Good layer adhesion, which reduces the chances of cracking.
- High flexibility, preventing brittleness during and after printing.
- Can handle mechanical stress and repeated loading.
- Smooth surface finish with minimal post-processing.

Q5(a). Discuss construction, working principle and applications of quantum dot sensitized solar cells (QDSSCs).

QDSCs

A quantum dot solar cell (QDSC) is a type of solar cell that utilizes quantum dots as a light-absorbing material to convert sunlight into electricity.

Construction

- **Transparent conducting electrode:** FTO glass (Fluorine-doped Tin Oxide)
- **Transparent Conductive Oxide Layer:** TiO₂ film
- **Quantum dots layer:** Light-absorbing semiconductor materials (CdSe or CdS)
- **Electrolyte:** Polysulphide is used as a redox electrolyte.
- **Counter Electrode:** used to complete the circuit and helps to generate electricity.

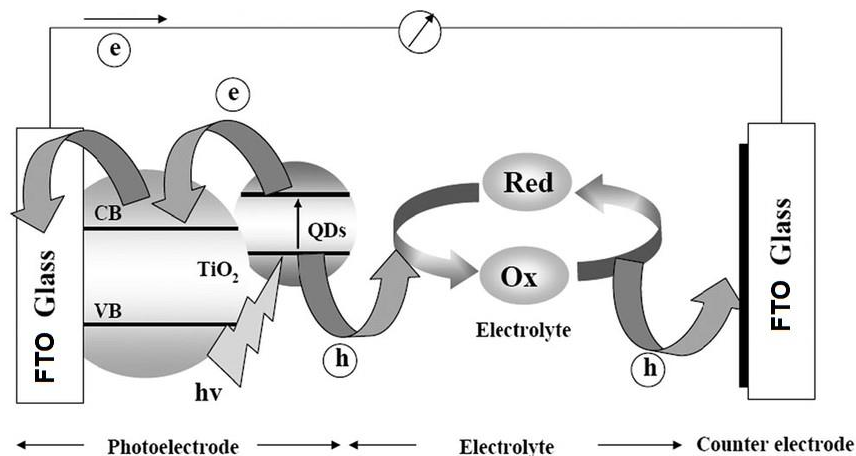

Working

a) Upon absorption of a photon, a quantum dot is excited from the ground state (QDs) to a higher energy state (QDs*)

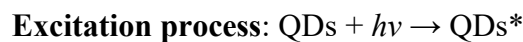

b) The absorption process results in the creation of electron-hole pair in the form of the *exciton*. Dissociation of the exciton occurs if the thermal energy exceeds its binding energy



c) The excited electron is then injected in the conduction band of the wide bandgap semiconductor nanostructured TiO₂ thin film. This process will cause the oxidation of the photosensitizer

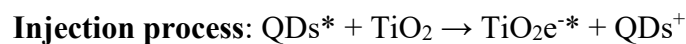

d) The injected electron is transported between the TiO₂ nanoparticles, and then gets extracted to a load where the work done is delivered as electrical energy.

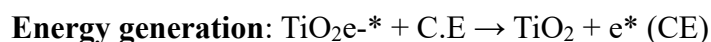

QDSCs applications

- It is used as light-emitting Diodes
- It is used as a photoconductor and photodetector

- It is used as a photovoltaic
- It is used in biomedicine
- It is used in catalysis

Q5(b). Describe the wet chemical synthesis of Cd–Se quantum dots and mention their applications.

Synthesis of Cd-Se Quantum dots by wet chemical method

The **wet chemical (colloidal synthesis) method** is the most common, as it is simple and cost-effective.

Precursors:

- **Cadmium source:** Cadmium salts (CdCl_2 , $\text{Cd}(\text{Ac})_2$).
- **Selenium source:** Sodium selenide (Na_2Se) dissolved in trioctylphosphine (TOP).

Reaction Medium: Organic solvents like **trioctylphosphine oxide (TOPO)** or oleic acid act as **capping agents to control particle size** and prevent aggregation.

Nucleation and Growth: Cd precursor and Se precursor are injected into a hot surfactant solution. At high temperature ($\sim 200\text{--}300^\circ\text{C}$) **nucleation occurs** and formation of tiny CdSe nanocrystals.

Purification: The nanocrystals are separated by precipitation (adding ethanol/acetone) and redispersed in solvents like toluene or hexane.

Applications of CdSe QDs

1. **Optoelectronic Devices: QLED displays, LEDs, and lasers**
2. **Solar Cells:** CdSe QDs enhance photovoltaic performance.
3. **Biological Imaging: cell and tissue imaging**
4. **Sensors:** CdSe QDs can detect chemicals, ions, or biomolecules
5. **Photocatalysis:** Effective in **hydrogen generation**

Q6(a). Explain synthesis, properties and applications of polymethyl methacrylate (PMMA).

Polymethyl Methacrylate (PMMA): PMMA is a transparent, strong, and lightweight polymer. It is often used as a safer alternative to glass.

Synthesis of PMMA:

- PMMA is made by polymerizing methyl methacrylate (MMA) monomers.
- The polymer is usually prepared by free-radical polymerization.
- A free-radical initiator produces reactive radicals.
- These radicals react with MMA monomers, opening the double bond and forming long chains.

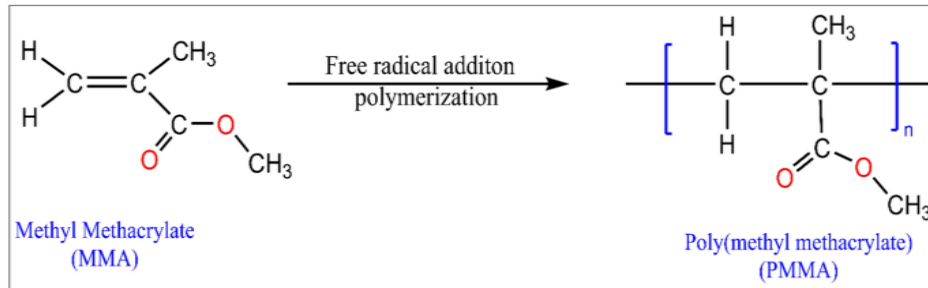

Properties of PMMA

- **High transparency:** It allows about 92% of visible light to pass through
- **Lightweight:** Much lighter than glass but still rigid.
- **Good scratch resistance:** Harder surface compared to other plastics.
- **Good chemical resistance:** Stable against many acids and bases.
- **Good weather resistance:** Does not yellow easily and can withstand sunlight.

Applications of PMMA

- **Windows and skylights** as a substitute for glass
- **Automobile tail lights and lamp cover**
- **Medical devices like bone cement** in orthopedic surgeries
- **Lenses for cameras, LED lights,** and instrument panels
- **Aquarium panels and protective barriers**

Q6(b). In a sample of a polymer, 100 molecules have a molecular mass of 2000 g/mol, 200 molecules have a molecular mass of 3000 g/mol, and 500 molecules have a molecular mass of 10,000 g/mol. Calculate the number average and weight average molecular mass of a polymer.

Given $N_1 = 100$ molecules, $M_1 = 2000$ g/mol

$N_2 = 200$ molecules, $M_2 = 3000$ g/mol

$N_3 = 500$ molecules, $M_3 = 10000$ g/mol

$$\begin{aligned}
 M_n \text{ (number average molecular weight)} &= \frac{\sum N_i M_i}{\sum N_i} \\
 &= (100 \times 2000) + (200 \times 3000) + (500 \times 10000) / (100+200+500) \\
 &= 5800000/800 \\
 &= \mathbf{7250 \text{ g/mol}}
 \end{aligned}$$

$$\begin{aligned}
 M_w \text{ (weight average molecular weight)} &= \frac{\sum N_i M_i^2}{\sum N_i M_i} \\
 &= [100 \times (2000)^2] + [200 \times (3000)^2] + [500 \times (10000)^2] / [(100 \times 2000) + (200 \times 3000) + (500 \times 10000)]
 \end{aligned}$$

$$= 5.22 \times 10^{10} / 5800000$$
$$= 9000 \text{ g/mol}$$

Q7(a). Apply the concept of green synthesis for the production of ZnO nanoparticles and mention its applications for IONT.

Green synthesis of ZnO nanoparticles

- **Preparation of plant extract:** Fresh plant leaves are washed, dried, and boiled in distilled water. The extract is used as a natural reducing and stabilizing agent.
- **Preparation of zinc precursor solution:** zinc nitrate or zinc acetate is dissolved in distilled water
- **Mixing of solutions:** The plant extract is added slowly to the zinc salt solution
- **Reaction and precipitation:** The mixture is heated and stirred, leading to the formation of a Zn-based precipitate due to reduction of Zn^{2+} ions.
- **Separation and washing:** The precipitate is filtered or centrifuged and washed with distilled water to remove impurities.
- **Drying and calcination:** The product is dried and then calcined at moderate temperature to obtain crystalline ZnO nanoparticles by an eco-friendly route.

Uses in magnetic RFID and IoNT applications

- **RF signal sensing and response:** ZnO help in sensing and responding to radio frequency signals used in RFID systems.
- **RFID tag components:** fabrication of small and lightweight RFID components without loss of performance.
- **Magnetic and electromagnetic interaction:** ZnO shows good interaction with electromagnetic fields, improving signal detection in magnetic RFID devices
- **Nano-sensors in IoNT:** ZnO nanoparticles act as sensing elements in IoNT systems

Q7(b). Discuss the synthesis and properties of alginate hydrogel with reference to its applications in brain–computer interfaces (BCIs).

Alginate is a natural polysaccharide extracted from brown seaweed.

Synthesis of Alginate Hydrogel

- Alginate is first dissolved in water to form a **sodium alginate solution**.
- The hydrogel is formed by adding **calcium ions** (Ca^{2+}).
- Calcium ions crosslink the alginate chains through an “**egg-box**” structure.
- This ionic crosslinking converts the liquid alginate solution into a **stable gel**.
- The process occurs under **mild conditions**.

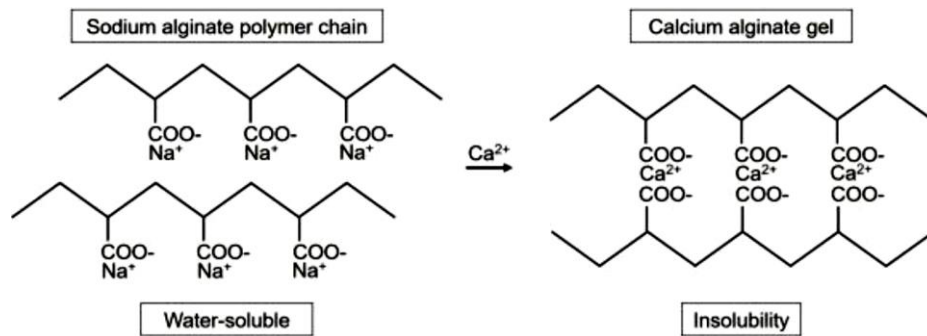

Properties of Alginate Hydrogel (any 4)

- **Biocompatibility:** non-toxic and well tolerated by brain tissue
- **High water content:** mechanical softness of neural tissue
- **Porous structure:** Allows diffusion of ions and signaling molecules
- **Electrical ion conductivity:** Supports ionic charge transport
- **Minimal inflammatory response:** Reduces damage at the brain–electrode interface.

Applications of Alginate Hydrogel in BCIs (any 4)

- **Soft coating on neural electrodes** to reduce mechanical mismatch with brain tissue.
- **Long-term signal stability** by minimizing scar tissue formation.
- Acts as **conductive interface** when combined with conductive polymers
- Supports **cell encapsulation**, enabling neuron growth near electrodes
- **Implantable neural probes** for recording and stimulation.

Q8(a). What are green solvents? Explain properties and applications of green solvents for server heat management.

Green solvents are environmentally friendly liquids that provide safe, efficient, and sustainable cooling for applications such as server heat management.

Properties of green solvents for server cooling

- **High thermal conductivity:** Green solvents can absorb and transfer heat efficiently, making them suitable for cooling high-power servers.
- **High boiling point and thermal stability:** They remain stable at elevated temperatures without evaporating quickly, ensuring safe and continuous cooling.
- **Low toxicity and non-flammability:** These solvents are safer for workers
- **Biodegradability and low environmental impact:** Green solvents break down naturally and produce minimal pollution
- **Chemical inertness:** They do not corrode server components, circuit boards, or metal surfaces.

Applications in server heat management

- **Immersion cooling of servers:** Green solvents act as dielectric fluids that directly cool server components.
- **Two-phase cooling systems:** absorb heat through phase change and release it by condensation to improve cooling efficiency.
- **Energy efficiency:** reduces air conditioning needs, lowering power consumption and costs.
- **Sustainable IT infrastructure:** Green solvents support eco-friendly data center designs and help reduce carbon footprint.

Q8(b). Explain the synthesis and properties of polylactic Acid (PLA) in touch screen applications.

Synthesis of Polylactic Acid (PLA)

- PLA is synthesized from *lactic acid*, which is produced by fermentation of corn starch or sugar.
- Lactic acid molecules are first converted into a cyclic compound called *lactide*.
- This lactide is then polymerized by *ring-opening polymerization* to form high-molecular-weight PLA.

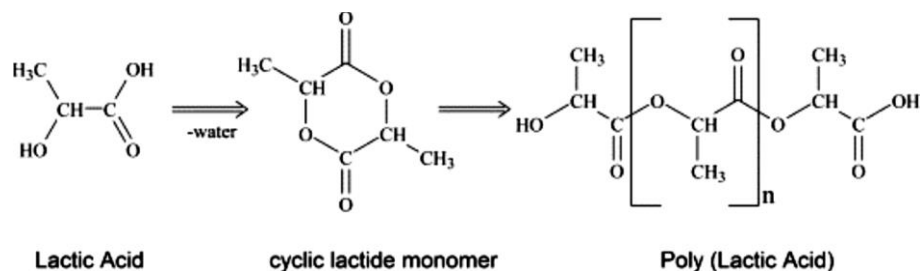

Properties of PLA

- Biodegradable and environmentally friendly.
- Good transparency and optical clarity.
- High mechanical strength and good film-forming ability.
- Lightweight with moderate thermal stability.

Uses of PLA in touch screen applications

- Used as a transparent substrate in touch screen components.
- Applied as protective films and coatings on touch panels.
- Helps reduce environmental impact while maintaining display quality.