

USN



Internal Assessment Test 1 – SEPT. 2018

Sub:	Nontraditional machining				Sub Code:	15ME554	Branch:	ME
Date:	08.09.18	Duration:	90 min's	Max Marks:	50	Sem / Sec:	V/A&B	OBE
<u>Answer any FIVE FULL Questions</u>								MARKS
1	Explain briefly the basic factors upon which the Nontraditional machining process is classified?					[10]	CO1	L2
2	Distinguish between Conventional and Nontraditional machining process.					[10]	CO1	L2
3	Explain with neat sketch the working principle of Ultrasonic machining process and also mention its advantages and disadvantages.					[10]	CO2	L2
4	Explain with neat sketch the working principle of Abrasive jet machining process and also mention its advantages and disadvantages.					[10]	CO2	L2
5	Explain how the following parameters influence the metal removal rate in abrasive jet machining process (1) Nozzle tip distance (2) Velocity of abrasive (3) Abrasive flow rate (4) Gas pressure.					[10]	CO2	L2
6.	Explain with neat sketch the working principle of water jet machining process and also mention its advantages and disadvantages					[10]	CO2	L2

CI CCI HOD

USN



Internal Assessment Test 1 – SEPT. 2018

Sub:	Nontraditional machining				Sub Code:	15ME554	Branch:	ME
Date:	08.09.18	Duration:	90 min's	Max Marks:	50	Sem / Sec:	V/A&B	OBE
<u>Answer any FIVE FULL Questions</u>								MARKS
1	Explain briefly the basic factors upon which the Nontraditional machining process is classified?					[10]	CO1	L2
2	Distinguish between Conventional and Nontraditional machining process.					[10]	CO1	L2
3	Explain with neat sketch the working principle of Ultrasonic machining process and also mention its advantages and disadvantages.					[10]	CO2	L2
4	Explain with neat sketch the working principle of Abrasive jet machining process and also mention its advantages and disadvantages.					[10]	CO2	L2
5	Explain how the following parameters influence the metal removal rate in abrasive jet machining process (1) Nozzle tip distance (2) Velocity of abrasive (3) Abrasive flow rate (4) Gas pressure.					[10]	CO2	L2
6.	Explain with neat sketch the working principle of water jet machining process and also mention its advantages and disadvantages.					[10]	CO2	L2

1. Classification of NTM processes is carried out depending on the nature of energy used for material removal.

1. Mechanical Processes: In this case mechanism the material removal is by Erosion/Shear process, the high velocity particles are made to hit the work piece under the influence of pneumatic or hydraulic pressure.

- Abrasive Jet Machining (AJM)
- Ultrasonic Machining (USM)
- Water Jet Machining (WJM)
- Abrasive Water Jet Machining (AWJM)

2. Electrochemical Processes: In this case mechanism the material removal is by Ion displacement process with the help of electrolytes.

- Electrochemical Machining (ECM)
- Electro Chemical Grinding (ECG)
- Electro Jet Drilling (EJD)

3. Electro-Thermal Processes: In this case mechanism the material removal is by fusion / vaporization process with the help of hot gases, radiation, ion stream etc.

- Electro-discharge machining (EDM)
- Laser Jet Machining (LJM)
- Electron Beam Machining (EBM)

4. Chemical Processes: In this case mechanism the material removal is by ablative reaction process with the help of suitable chemicals like corrosive agents.

- Chemical Milling (CHM)
- Photochemical Milling (PCM)

2.

Sl. No	Conventional Machining	Non traditional Machining
1.	The cutting tool and work piece are always in physical contact with relative motion with each other, which results in friction and tool wear.	There is no physical contact between the tool and work piece, In some non traditional process tool wear exists.
2.	Material removal rate is limited by mechanical properties of work material.	NTM can machine difficult to cut and hard to cut materials like titanium, ceramics, SST, composites, semiconducting materials.
3.	Relative motion between the tool and work is typically rotary or reciprocating. Thus the shape of work is limited to circular or flat shapes. In spite of CNC systems, production of 3D surfaces is still a difficult task.	Many NTM are capable of producing complex 3D shapes and cavities.
4.	Machining of small cavities , slits , blind holes or through holes are difficult	Machining of small cavities, slits and Production of non-circular, micro sized, large aspect ratio, shall entry angle holes are easy using NTM
5.	Use relative simple and inexpensive machinery and readily available cutting tools	Non traditional processes requires expensive tools and equipment as well as skilled labour, which increase the production cost significantly
6.	Capital cost and maintenance cost is low	Capital cost and maintenance cost is high

7.	Traditional processes are well established and physics of process is well understood	Mechanics of Material removal of Some of NTM process are still under research
8.	Conventional process mostly uses mechanical energy	Most NTM uses energy in direct form For example: laser, Electron beam in its direct forms are used in LBM and EBM respectively.
9.	Surface finish and tolerances are limited by machining inaccuracies	High surface finish(up to 0.1 micron) and tolerances (25 Microns)can be achieved
10.	High metal removal rate.	Low material removal rate.

3. It works on the same principle of ultrasonic welding. This machining uses ultrasonic waves to produce high frequency force of low amplitude, which act as driving force of abrasive. Ultrasonic machine generates high frequency vibrating wave of frequency about 20000 to 30000 Hz and amplitude about 25-50 micron. This high frequency vibration transfer to abrasive particle contains in abrasive slurry. This leads indentation of abrasive particle to brittle work piece and removes metal from the contact surface.

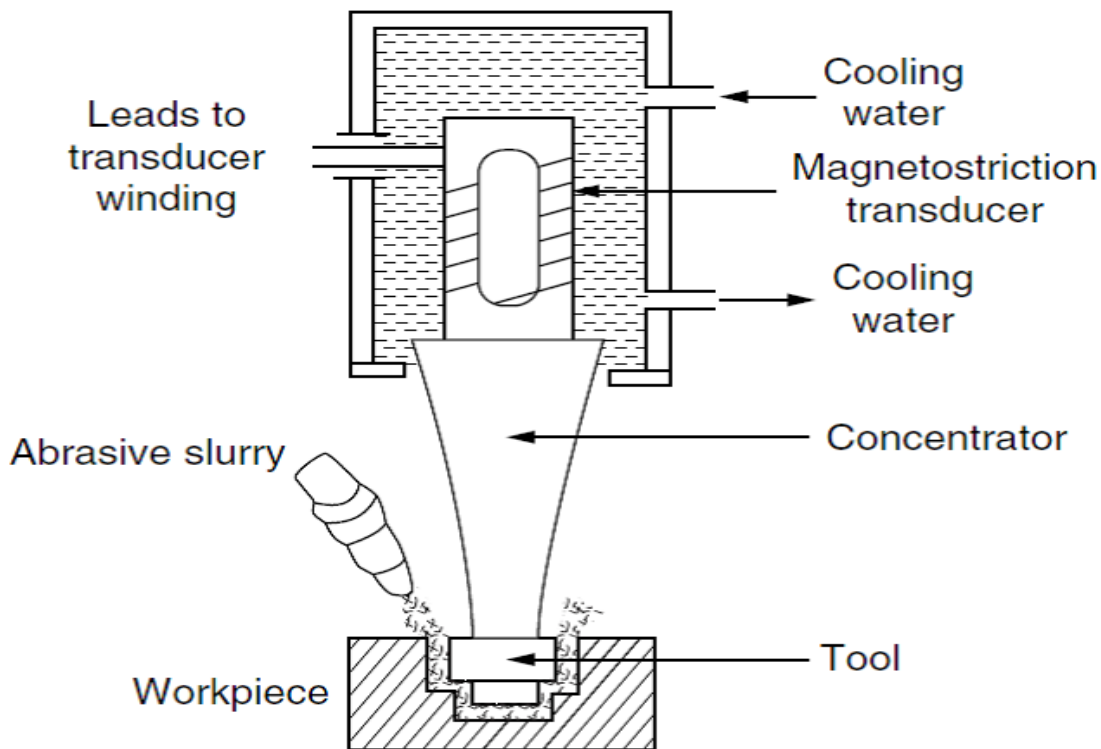

In ultrasonic machining, tool of desired shape vibrates at ultrasonic frequency (19 to 25 kHz.) with an amplitude of 15-50 Microns over work piece. Generally tool is pressed down with a feed force F . Between the tool and work, machining zone is flooded with hard abrasive particles generally in the form of water based slurry. As the tool vibrates over the work piece, abrasive particles acts as indenter and indent both work and tool material . Abrasive particles , as they indent , the work material would remove the material from both tool and work piece. In Ultrasonic machining material removal is due to crack initiation, propagation and brittle fracture of material. USM is used for machining hard and brittle materials, which are poor conductors of electricity and thus cannot be processed by Electrochemical machining (ECM) or Electro discharge machining (EDM). The tool in USM is made to vibrate with high frequency on to the work surface in the midst of the flowing slurry. The main reason for using ultrasonic frequency is to provide better performance. Audible frequencies of required intensities would be heard as extremely loud sound and would cause fatigue and even permanent damage to the auditory apparatus.

Power Source:

As we know, this machining process requires high frequency ultrasonic wave. So a high frequency high voltage power supply require for this process. This unit converts low frequency electric voltage (60 Hz) into high frequency electric voltage (20k Hz).

Magnetostrictive transducer:

As we know, transducer is a device which converts electric single into mechanical vibration. In ultrasonic machining magnetostrictive type transducer is used to generate mechanical vibration. This transducer is made by nickel or nickel alloy.

Booster:

The mechanical vibration generated by transducer is passes through booster which amplify it and supply to the horn.

Tool:

The tool used in ultrasonic machining should be such that indentation by abrasive particle, does not leads to brittle fracture of it. Thus the tool is made by tough, strong and ductile materials like steel, stainless steel etc.

Tool holder or Horn:

As the name implies this unit connects the tool to the transducer. It transfers amplified vibration from booster to the tool. It should have high endurance limit.

Abrasive Slurry:

A water based slurry of abrasive particle used as abrasive slurry in ultrasonic machining. Silicon carbide, aluminum oxide, boron carbide are used as abrasive particle in this slurry. A slurry delivery and return mechanism is also used in USM.

- First the low frequency electric current passes through electric supply. This low frequency current converts into high frequency current through some electrical equipment.
- This high frequency current passes through transducer. The transducer converts this high frequency electric single into high frequency mechanical vibration.
- This mechanical vibration passes through booster. The booster amplify this high frequency vibration and send to horn.
- Horn which is also known as tool holder, transfer this amplified vibration to tool which makes tool vibrate at ultrasonic frequency.
- As the tool vibrates, it makes abrasive particle to vibrate at this high frequency. This abrasive particle strikes to the work piece and remove metal form it.

Advantages:

- Hard material can be easily machined by this method.
- No heat generated in work so there is no problem of work hardening or change in structure of work piece.
- Non-conductive metals or non-metals, which cannot be machined by ECM of EDM can be machined by it.
- It does not form chips of significant size.

Disadvantages:

- It is quite slower than other mechanical process.
- Tool wear is high because abrasive particle affect both work-piece and tool.
- It can machine only hard material. Ductile metal cannot be machine by this method.
- It cannot used to drill deep hole.

4. The gap between nozzle tip and work surface has great influence on the diameter of cut, its shape and size and also rate of material removal. It is clear that the SOD or stand off distance, changes the spread of abrasive particles on the working surface and increases the diameter of the cut. The process makes use of an abrasive jet with high velocity, to remove material and provide smooth surface finish to hard metallic work pieces. It is similar to Water Jet Machining (WJM). A simple schematic diagram of Abrasive Jet Machining (AJM) is shown below:

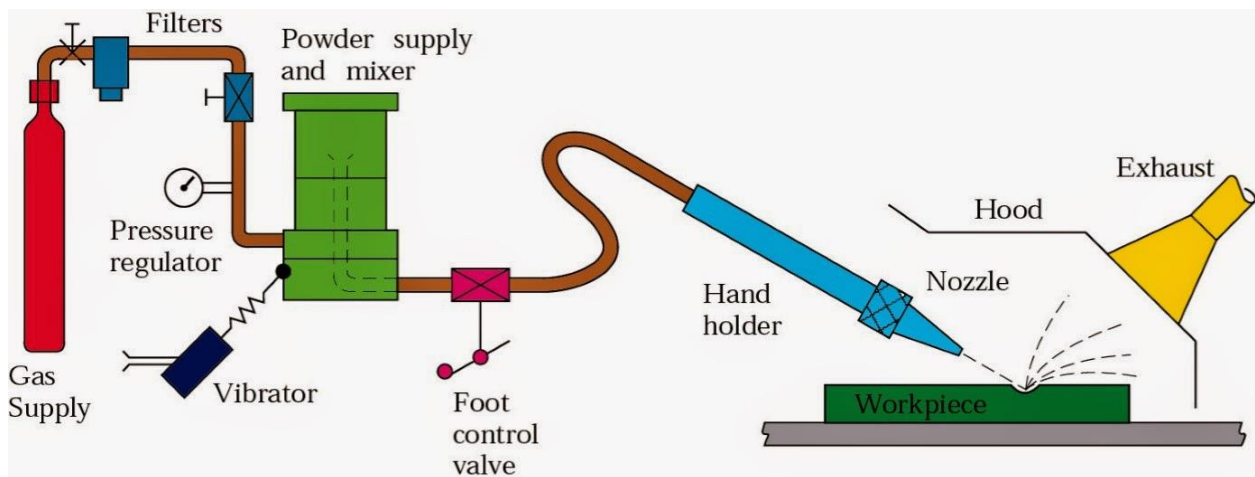

Construction of Abrasive Jet Machining (AJM):

The constructional requirements of Abrasive Jet Machining (AJM) are listed and described below:

1. **Abrasive jet:** It is a mixture of a gas (or air) and abrasive particles. Gas used is carbon-dioxide or nitrogen or compressed air. The selection of abrasive particles depends on the hardness and Metal Removal Rate (MRR) of the workpiece. Most commonly, aluminium oxide or silicon carbide particles are used.
2. **Mixing chamber:** It is used to mix the gas and abrasive particles.
3. **Filter:** It filters the gas before entering the compressor and mixing chamber.
4. **Compressor:** It pressurizes the gas.
5. **Hopper:** Hopper is used for feeding the abrasive powder.
6. **Pressure gauges and flow regulators:** They are used to control the pressure and regulate the flow rate of abrasive jet.
7. **Vibrator:** It is provided below the mixing chamber. It controls the abrasive powder feed rate in the mixing chamber.
8. **Nozzle:** It forces the abrasive jet over the workpiece. Nozzle is made of hard and resistant material like tungsten carbide.

Working:

Dry air or gas is filtered and compressed by passing it through the filter and compressor.

A pressure gauge and a flow regulator are used to control the pressure and regulate the flow rate of the compressed air.

Compressed air is then passed into the mixing chamber. In the mixing chamber, abrasive powder is fed. A vibrator is used to control the feed of the abrasive powder. The abrasive powder and the

compressed air are thoroughly mixed in the chamber. The pressure of this mixture is regulated and sent to nozzle.

The nozzle increases the velocity of the mixture at the expense of its pressure. A fine abrasive jet is rendered by the nozzle. This jet is used to remove unwanted material from the workpiece.

For a good understanding of construction and working of AJM, refer the schematic diagram above.

Operations that can be performed using Abrasive Jet Machining (AJM):

The following are some of the operations that can be performed using Abrasive Jet Machining:

1. Drilling
2. Boring
3. Surface finishing
4. Cutting
5. Cleaning
6. Deburring
7. Etching
8. Trimming
9. Milling

Advantages of Abrasive Jet Machining:

- Surface of the workpiece is cleaned automatically.
- Smooth surface finish can be obtained.
- Equipment cost is low.
- Hard materials and materials of high strength can be easily machined.
- A process quite suitable for machining brittle, heat resistant and fragile materials like, ceramic, glass, germanium, etc.
- It could be used to cut, drill, polish, debur, clean the materials.

Disadvantages of Abrasive Jet Machining:

- Metal removal rate is low
- In certain circumstances, abrasive particles might settle over the work piece.
- Nozzle life is less. Nozzle should be maintained periodically.
- Abrasive Jet Machining cannot be used to machine soft materials.
- The tapering of hole mainly when the depth of the hole is more, becomes inevitable.
- It needs a dust collecting chamber to prevent air pollution.
- The abrasive particles might remain embedded into work surface.
- Abrasive particles are not reusable.

5.

1. Nozzle tip distance: Stand-off distance is defined as the distance between the face of the nozzle and the work surface of the work. SOD has been found to have considerable effect on the work material and accuracy. A large SOD results in flaring of jet which leads to poor accuracy. It is clear from figure that MRR increase with nozzle tip distance or Stand-off distance up to certain distance and then decreases. Penetration rate also increases with SOD and then decreases. Decrease in SOD improves accuracy, decreases width, and reduces taper in machined groove. However light operation like cleaning, frosting etc are conducted with large SOD.(say 12.5 to 75mm)

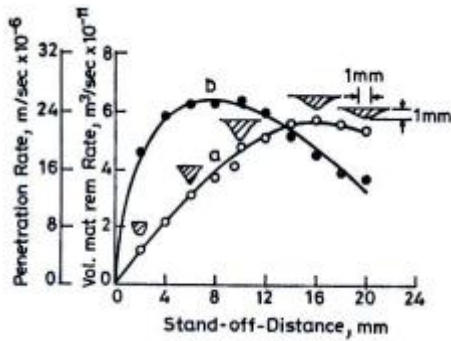

2. Effect of exit gas velocity and abrasive particle density: The velocity of carrier gas conveying the abrasive particles changes considerably with the change of abrasive particle density as indicated in figure. The exit velocity of gas can be increased to critical velocity when the internal gas pressure is nearly twice the pressure at exit of nozzle for the abrasive particle density is zero. If the density of abrasive particles is gradually increased exit velocity will go on decreasing for the same pressure condition. It is due to fact that Kinetic energy of gas is utilized for transporting the abrasive particle.

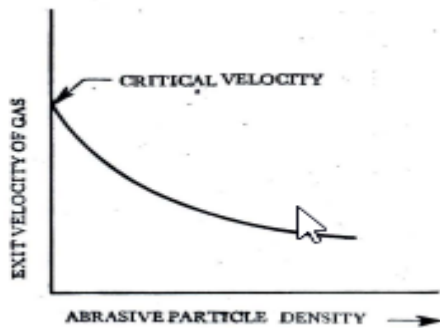

3. Effect of abrasive flow rate and grain size on MRR It is clear from the figure that at a particular pressure MRR increase with increase of abrasive flow rate and is influenced by size of abrasive particles. But after reaching optimum value, MRR decreases with further increase of abrasive flow rate. This is owing to the fact that Mass flow rate of gas decreases with increase of abrasive flow rate and hence mixing ratio increases causing a decrease in material removal rate because of decreasing energy available for erosion.

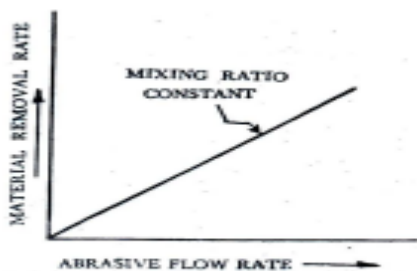

4. Effect of gas pressure on MRR : The abrasive flow rate can be increased by increasing the flow rate of the carrier gas. This is only possible by increasing the internal gas pressure as shown in the figure. As the internal gas pressure increases abrasive mass flow rate increase and thus MRR increases. As a matter of fact, the material removal rate will increase with the increase in gas

pressure Kinetic energy of the abrasive particles is responsible for the removal of material by erosion process. The abrasive must impinge on the work surface with minimum velocity for machining glass by SIC particle is found to be around 150m/s.

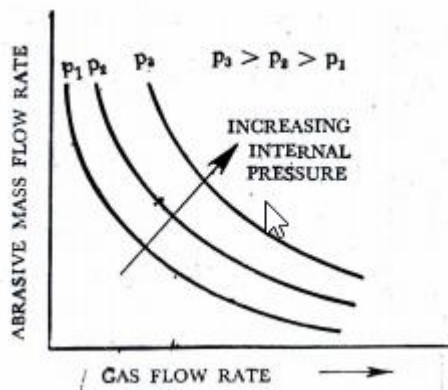

6. The apparatus of water jet machining consists of the following components:

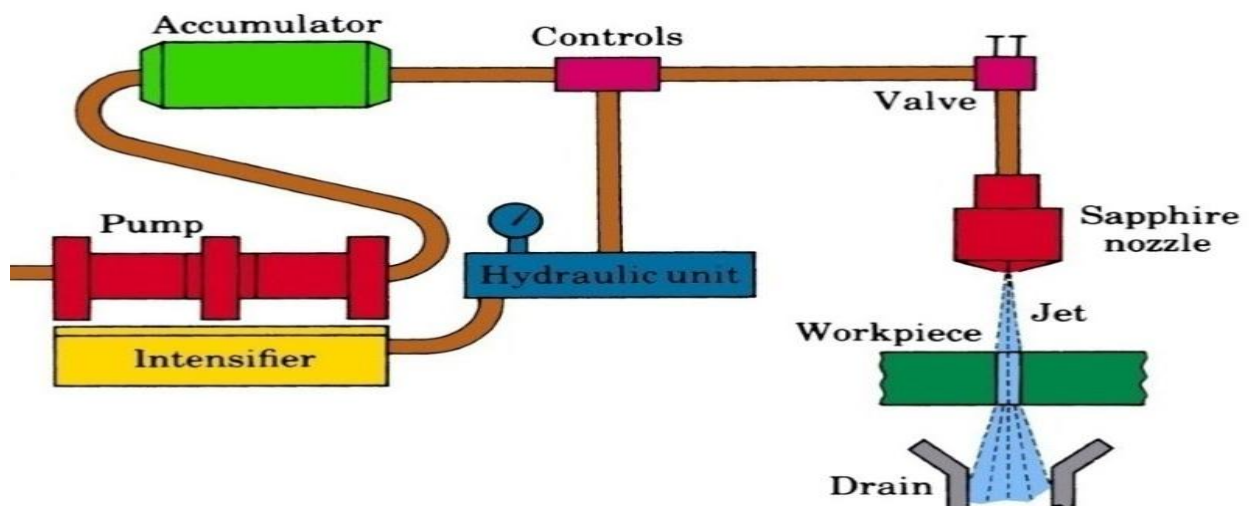

1. **Reservoir:** It is used for storing water that is to be used in the machining operation.
2. **Pump:** It pumps the water from the reservoir.
3. **Intensifier:** It is connected to the pump. It pressurizes the water acquired from the pump to a desired level.
4. **Accumulator:** It is used for temporarily storing the pressurized water. It is connected to the flow regulator through a control valve.
5. **Control Valve:** It controls the direction and pressure of pressurized water that is to be supplied to the nozzle.
6. **Flow regulator:** It is used to regulate the flow of water.
7. **Nozzle:** It renders the pressurized water as a water jet at high velocity.

Working of Water Jet Machining (WJM):

- Water from the reservoir is pumped to the intensifier using a hydraulic pump.
- The intensifier increases the pressure of the water to the required level. Usually, the water is pressurized to 200 to 400 MPa.

- Pressurized water is then sent to the accumulator. The accumulator temporarily stores the pressurized water.
- Pressurized water then enters the nozzle by passing through the control valve and flow regulator.
- Control valve controls the direction of water and limits the pressure of water under permissible limits.
- Flow regulator regulates and controls the flow rate of water.
- Pressurized water finally enters the nozzle. Here, it expands with a tremendous increase in its kinetic energy. High velocity water jet is produced by the nozzle.
- When this water jet strikes the work piece, stresses are induced. These stresses are used to remove material from the work piece.
- The water used in water jet machining may or may not be used with stabilizers. Stabilizers are substances that improve the quality of water jet by preventing its fragmentation.
- For a good understanding of water jet machining, refer the schematic diagram above.

Advantages of Water Jet Machining (WJM):

1. Water jet machining is a relatively fast process.
2. It prevents the formation of heat affected zones on the work piece.
3. It automatically cleans the surface of the work piece.
4. WJM has excellent precision. Tolerances of the order of $\pm 0.005''$ can be obtained.
5. It does not produce any hazardous gas.
6. It is eco-friendly.
7. It has the ability to cut materials without disturbing its original structure. And this happens so because there is not heat affected zone (HAZ).
8. It is capable of producing complex and intricate cuts in materials.
9. The work area of in this machining process remains clean and dust free.
10. It has low operating and maintenance cost because it has no moving parts.
11. The thermal damage to the workpiece is negligible due to no heat generation.
12. It is capable of cutting softer materials (WJM) like rubber, plastics or wood as well as harder material (AWJM) like granite.
13. It is environment friendly as it does not create any pollution or toxic products.

Disadvantages of Water Jet Machining:

1. Only soft materials can be machined.
2. Very thick materials cannot be easily machined.
3. Initial investment is high.

Scheme of Evaluation

Question number	Particulars	Marks distribution
1.	4 classifications	2 ¹ / ₂ marks each
2.	10 differences	1 mark each 1x10= 10 marks
3.	Sketch Working process Advantages and disadvantages	4 marks 4 marks 2 marks
4.	Sketch Working process Advantages and disadvantages	4 marks 4 marks 2 marks
5.	(1) Nozzle tip distance (2) Velocity of abrasive (3) Abrasive flow rate (4) Gas pressure.	2 ¹ / ₂ marks each
6.	Sketch Working process Advantages and disadvantages	4 marks 4 marks 2 marks