

# CBCS Scheme

USN

--	--	--	--	--	--	--	--	--	--

15CV33

Third Semester B.E. Degree Examination, Dec.2017/Jan.2018

## Fluid Mechanics

Time: 3 hrs.

Max. Marks: 80

Note: Answer any FIVE full questions, choosing one full question from each module.

### Module-1

- 1 a. Define the terms 'continuum' and 'rheology'. (04 Marks)  
b. Explain why an inflated balloon will rise to a definite height once it starts to rise, whereas a submarine will always sink to the bottom of ocean once it starts to sink, if no changes are made. How then can a submarine stay at a definite level under the water? (04 Marks)  
c. Prove that the relative density of mixture of 'n' fluids is greater when equal volumes are taken than when equal weights are taken, assuming no changes in volume as the result of mixing. (08 Marks)

CMRIT LIBRARY  
BANGALORE - 560 037

OR

- 2 a. Why does the viscosity of a liquid decrease with increase in temperature whereas it increases with increase in temperature in the case of gas? (04 Marks)  
b. Find the increase in the pressure required to reduce the volume of water by 0.8 percent. Given  $K = 2.075 \times 10^9 \text{ Nm}^{-2}$ . (04 Marks)  
c. Determine the pressure difference ( $p_A - p_B$ ) in Fig. Q2(c).

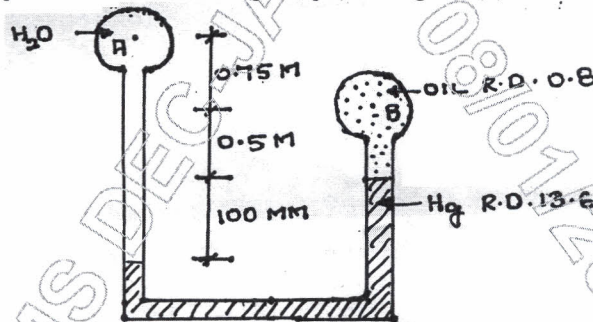

Fig. Q2(c)

(08 Marks)

### Module-2

- 3 a. Prove that for a plate kept vertical in a liquid will have its centre of pressure below its centroid. (07 Marks)  
b. In each of the following cases state, giving reasons whether the flow is steady, unsteady, uniform or non uniform.  
i)  $U = 10xt + 15x^2$   
ii)  $U = 20$   
iii) Flow in pipe bend with constant discharge.  
iv) Flow in a converging pipe in which discharge is gradually increased.  
v) Flow in a constant diameter pipe in which discharge is continuously increasing. (05 Marks)  
c. If the equation of stream lines for a given fluid flow problem is  $x^2 - y^2 = \text{constant}$ , determine the magnitude and direction of velocity vector at (3, 4). (04 Marks)

OR

- 4 a. A  $60^\circ$  radial gate of 5m radius and 3m length stores water upto its top as shown in Fig.Q4(a). Determine the components of total force and its point of application.

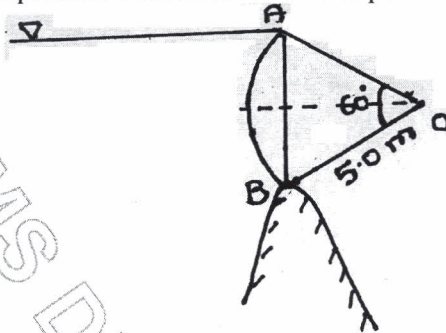

Fig.Q4(a)

- b. Show that the stream lines and velocity potential lines cross each other orthogonally. (06 Marks)
- c. Stating the assumptions made, derive the Euler's equation. Hence obtain Bernoulli's equation from it. (05 Marks)
- (05 Marks)

**Module-3**

- 5 a. A pitot tube is mounted on an air plane to indicate the speed of the plane relative to the prevailing wind. What differential pressure intensity in kPa will the instrument register when the plane is travelling at a speed of 200 kmph in a wind of 60 kmph blowing against the direction of the plane?  $\rho_{\text{air}} = 1.2 \text{ kg/m}^3$  (05 Marks)
- b. State impulse momentum equation. Derive the expression for force exerted by a flowing fluid on a pipe bend. (05 Marks)
- c. Derive the equation for the discharge through the venturimeter. (06 Marks)

OR

**CMRIT LIBRARY**  
BANGALORE - 560 037

- 6 a. In a  $45^\circ$  bend a rectangular air duct of  $1 \text{ m}^2$  cross sectional area is gradually reduced to  $0.5 \text{ m}^2$  area. Find the magnitude and direction of force required to hold the duct in position if the velocity of flow at  $1 \text{ m}^2$  section is  $10 \text{ ms}^{-1}$ , and pressure is  $30 \text{ kN/m}^2$ . Take the specific weight of air as  $0.0116 \text{ kN/m}^3$ . (06 Marks)
- b. A pitot static tube is inserted in a 30 cm diameter pipe. The static pressure in the pipe is 12.5 cm of mercury (vacuum). The stagnation pressure at the centre of the pipe is  $1.15 \text{ N/cm}^2$  (gauge). Calculate the rate of flow of water through the pipe. The mean velocity of flow is 0.875 times the central velocity. Take  $C_v = 0.985$ . (06 Marks)
- c. Define the terms 'Orifice' and 'Mouthpiece'. Give the detailed classification of mouth pieces with neat sketches. (04 Marks)

**Module-4**

- 7 a. Water flows over a rectangular weir in wide at a depth of 15 cm and afterwards passes through a triangular right angled weir. Taking  $C_d$  for rectangular weir 0.62 and for triangular 0.59. Find the depth over the triangular weir. (06 Marks)
- b. Explain cippolletti notch. What is the advantage of cippolletti notch over trapezoidal notch? Give the equation of discharge over a cippolletti notch. (10 Marks)

OR

- 8 a. A rectangular notch 40 cm long is used for measuring a discharge of 30 LPS. An error of 1.5 mm was made while measuring the head over the notch. Calculate the percent error in the discharge. Take  $C_d = 0.6$ . (06 Marks)

- b. Mention the advantages of triangular notch over rectangular notch. (04 Marks)
- c. Define hydraulic coefficients and to discuss how to determine the hydraulic coefficients experimentally. (06 Marks)

**Module-5**

- 9 a. Define the terms 'compound pipe' and 'equivalent pipe'. Derive the expression for diameter of equivalent pipe. (06 Marks)
- b. Water flowing through a rigid pipe of diameter 500 mm with 1.5 m/s is suddenly brought to rest. Find the instantaneous pressure rise if  $K_{\text{water}} = 2 \text{ GPa}$ . (04 Marks)
- c. A compound piping system consists of 1800 m of 0.5 m, 1200 m of 0.4 m and 600 m of 0.3 m new cast iron pipes connected in series. Convert the system to: i) Equivalent length of 0.4 m pipe; ii) Equivalent size pipe 3600 m long. (06 Marks)

**OR**

- 10 a. Derive an expression for instantaneous rise in pressure in an elastic pipe due to sudden closure of valve. (08 Marks)
- b. Water is to be supplied to the inhabitants of a college campus, through a supply main. The following data is given:  
 Distance of the reservoir from the campus = 3000 m  
 Number of inhabitants = 4000  
 Consumption of water per day of each inhabitants = 180 liters  
 Loss of head due to friction = 18 m  
 Coefficient of friction for the pipe,  $f = 0.007$   
 If one half of the daily supply is pumped in 8 hours, determine the size of the supply main. (08 Marks)

**CMRIT LIBRARY**  
BANGALORE - 560 037

\*\*\*\*\*